



ИБП Eaton 93PS-XX(40)-YY-8 - Внешние батарейные шкафы Eaton 93PS - Руководство пользователя

Постоянная ссылка на страницу: <https://eaton-power.ru/catalog/eaton-93ps/93ps-xx-40-yy-8/>

# USER'S AND INSTALLATION GUIDE

## Eaton Small External Battery Cabinet (EBC-S) and Large External Battery Cabinet (EBC-L)

P-164000504

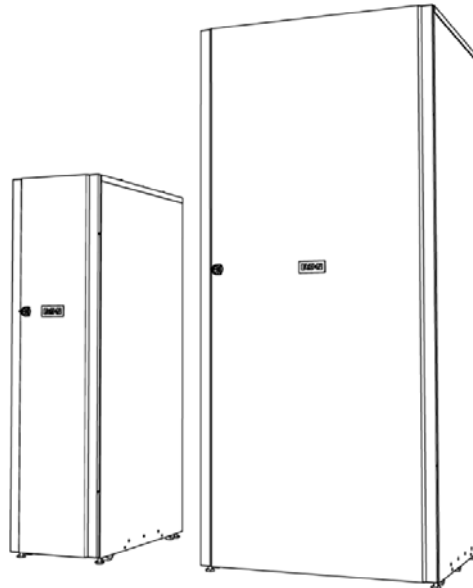

Copyright © 2015 Eaton Corporation

This manual contains important information for the installation and maintenance of the equipment before operating the equipment and

This is a product for commercial and industrial environment. Installation restrictions must be followed to prevent disturbances.

The contents of this manual are the property of Eaton and may be reproduced (even extracts) without the written permission of Eaton. Every care has been taken to ensure the accuracy of this manual, but no liability can be accepted for any damage caused by making design modifications is required. Unauthorized copying and lending

### Eaton Power Quality Oy

**Address:** Koskelontie 13  
FI-02920 Espoo  
Finland

**Internet:** [www.eaton.eu](http://www.eaton.eu)

### Approvals and version history

REVISION	DATE	DESCR
001	04.06.2015	First i

Original instructions \_X\_ / Tran

# Contents

- Contents ..... 4**
- 1 How to read this manual ..... 5**
  - 1.1 Safety-related signs ..... 5
  - 1.2 Safety symbols ..... 5
    - 1.2.1 Hazard symbols ..... 5
    - 1.2.2 Prohibited action symbols ..... 6
    - 1.2.3 Mandatory action symbols ..... 6
  - 1.3 Conventions used in this document ..... 6
- 2 Safety instructions ..... 7**
  - 2.1 Audience ..... 10
  - 2.2 CE marking ..... 10
  - 2.3 User precautions ..... 10
  - 2.4 Environment ..... 11
  - 2.5 Symbols on the UPS and accessories ..... 11
  - 2.6 For more information ..... 12
- 3 Installation ..... 13**
  - 3.1 Installation checklist ..... 14
  - 3.2 Installation considerations ..... 15
  - 3.3 Unpacking and unloading the EBC ..... 18
  - 3.4 Installing the EBC ..... 21
  - 3.5 Installation compatibility of the EBCs ..... 25
  - 3.6 Operation ..... 25
- 4 Maintenance ..... 26**
  - 4.1 Important safety instructions ..... 26
  - 4.2 Performing preventive maintenance ..... 27
    - 4.2.1 Periodic maintenance ..... 27
    - 4.2.2 Annual maintenance ..... 28
    - 4.2.3 Battery maintenance ..... 28
  - 4.3 Recycling the used UPS or batteries ..... 28
  - 4.4 Maintenance training ..... 30
- 5 Technical data ..... 31**
  - 5.1 Standards ..... 31
  - 5.2 Battery specification ..... 32
  - 5.3 Environmental specifications ..... 32
- 6 Warranty ..... 33**
  - 6.1 General ..... 33
  - 6.2 Whom to contact in case of Warranty ..... 34

# 1 How to read this manual

## 1.1 Safety-related signs

The following table explains the symbols used in this document.

 <b>DANGER</b>	<b>DANGER</b> indicates a situation which, if not avoided, will result in death or serious injury.
 <b>WARNING</b>	<b>WARNING</b> indicates a situation which, if not avoided, may result in death or damage to property.
 <b>CAUTION</b>	<b>CAUTION</b> indicates a situation which, if not avoided, may result in minor or moderate damage to property.



*NOTE: Notes are used to indicate important information.*

## 1.2 Safety symbols

### 1.2.1 Hazard symbols

These symbols indicate a hazard. They are used to warn of situations, which may result in personal injury.



General warning symbol



Electrical hazard



Battery hazard

### 1.2.2 Prohibited action symbols

These symbols are used to indicate an action that should not be taken.



General symbol for prohibited action



No smoking



Limited or restricted access

### 1.2.3 Mandatory action symbols

These symbols are used to indicate an action that must be taken.



General symbol for mandatory action



Disconnect from power source



Read the manual or instructions

### 1.3 Conventions used in this document

This document uses the following type conventions:

- **Bold type** highlights important concepts in discussions, key terms in procedures and menu options, or represents a command or option that you type or enter at a prompt.
- *Italic type* highlights notes and new terms when they are defined.

## 2 Safety instructions



Important safety instructions  
Save these instructions!

This document contains important information for you to read during the installation, operation, and maintenance of the cabinet and the batteries. Read this document before you use the equipment. Keep this manual in a safe place.

The battery cabinet contains components that can cause electrical shock and foreign object damage. It is a sophisticated power system and should be installed and serviced by a qualified technician.



This battery cabinet carries lethal voltages. Work should be performed by authorized personnel. Do not attempt to service or replace serviceable parts inside the cabinet.



Operations inside the battery cabinet should be performed by an authorized engineer from the manufacturer.

 **WARNING**

To reduce the risk of fire or electric shock, install this battery cabinet in a temperature and humidity controlled, indoor environment that is free of conductive contaminants.

The ambient temperature must not exceed 40 °C (104 °F). Do not operate the battery cabinet near water or excessive humidity (95% maximum). The system is not intended for outdoor use.

Before you start any installation or service work, make sure that all AC and DC power sources are disconnected. Power may come from multiple sources. Also ensure system grounding / PE continuity.

In a parallel system, the output terminals may be energized even when the cabinet is turned off.

Batteries can present a risk of electrical shock or burn from high short-circuit current.

Electric energy hazard. Do not attempt to alter any battery wiring or connectors. Attempting to alter wiring can cause injury.

Do not open or mutilate batteries. Released electrolyte may be toxic and is harmful to the skin and eyes.

**IMPORTANT:** The battery may consist of multiple parallel strings. Make sure that you disconnect all strings before installation.



Only qualified service personnel should perform the work. All required precautions are allowed on batteries. Keep unauthorized personnel away from the batteries. Before you install or replace batteries, read the safety instructions, cautions, and notes concerning the batteries. Disconnect the batteries when you are working on them.

Make sure that your replacement batteries are the same voltage and type as the battery that you are replacing.

Before you connect or disconnect the batteries, disconnect the charging source by opening the main power switch.

Check if the battery is inadvertently connected to a source of the ground. Contacting the ground can cause a risk of electric shock or burn. Make sure that the connection before you work on the batteries. The risk of electric shock is less likely.

Dispose of batteries according to the local regulations.

Do not dispose of batteries in fire. Batteries may explode.

To ensure proper cooling airflow, do not block the front panels. Dangerous voltages inside the cabinet may be present when the front panels are installed.

Do not install or operate the battery cabinet near power sources.

Keep the operating environment clean and dry. See the document.

Keep the surroundings of the battery cabinet free from excess moisture.

Observe all DANGER, CAUTION, and WARNING labels inside and outside of the equipment.

## 2.1 Audience

The intended audience of this document is as follows:

- People who plan and perform the installation of the UPS system
- People who use the UPS system

This document provides guidelines for how to check the external battery cabinet delivery and how to install and operate the cabinet.

The reader is expected to know the fundamentals of electricity, wiring, electrical components and electrical schematic symbols. This document is written for a global reader.

### CAUTION



Read this document before you start to operate or perform work on the UPS system.

## 2.2 CE marking

The product has a CE marking in compliance with the following European directives:

- LV Directive (Safety) 2006/95/EC

Declarations of conformity with UPS harmonized standards and directives EN 62040-1 (Safety) is available at [www.eaton.eu](http://www.eaton.eu) or by contacting your nearest Eaton office or authorized partner.

## 2.3 User precautions

The only permitted user operation is to turn the battery circuit breaker on or off.

Follow the precautions and only perform the described operations. Any deviation from the instructions can be dangerous to the user or cause accidental load loss.

### DANGER



Do not open any screws in the unit. Failure to recognize the electrical hazards can prove fatal.

## 2.4 Environment

The external battery cabinet must be installed in accordance with the recommendations in this document. The cabinet should be installed in an airtight room, in the presence of dust, in an environment exceeding the specified limits.

An excessive amount of dust in the room where the external battery cabinet is installed may cause damage or reduce the life of the battery cabinet from the outside. To maximize internal battery service life, the recommended temperature range is from +20°C to +40°C.



During charge, float charge, and discharge, hydrogen and oxygen gases are produced from the batteries into the surrounding environment. An explosion can be created if the hydrogen concentration in the air reaches 4% to 75%. Ensure the necessary air flow in the room and cabinet location.

Ensure adequate air ventilation in the room where the external battery cabinets are installed. For the EBC-S, the minimum required air flow is 6.2 m<sup>3</sup>/hour and the minimum required area is 174 cm<sup>2</sup> when natural ventilation is used. For the EBC-L, the minimum air flow is 3.8 m<sup>3</sup>/hour and the minimum required area for inlet and outlet is 108 cm<sup>2</sup> when natural ventilation is used.

## 2.5 Symbols on the UPS

The following are examples of symbols used on the UPS and accessories. The symbols are:



RISK OF FIRE  
Indicates a risk of fire associated with the product.



**CAUTION: REFER TO OPERATOR'S MANUAL**  
Refer to your operator's manual for additional information, such as important operating and maintenance instructions.



This symbol indicates that you may not discard the UPS or the UPS batteries in the trash. This product involves sealed, lead-acid batteries and they must be disposed of properly. For more information, contact your local recycling / reuse or hazardous waste center.



This symbol indicates that you must not discard waste electrical or electronic equipment (WEEE) in the trash. For proper disposal, contact your local recycling / reuse or hazardous waste center.

## 2.6 For more information

Address any inquiries about the UPS and the battery cabinet to the local office or an agent authorized by the manufacturer. Quote the type code and the serial number of the equipment.

Call your local service representative if you need help with any of the following:

- scheduling initial startup
- regional locations and telephone numbers
- a question about any of the information in this manual
- a question that this manual does not answer

## 3 Installation

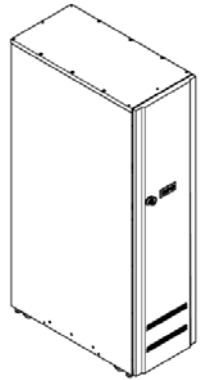

Figure 1. The small and the large external battery cabinet.

The Eaton external battery cabinet provides backup power to safeguard operations during other power interruptions. The product line. There are two different battery cabinet, EBC-S and the

The EBC-S is designed to be used with a UPS (UPS) rated up to 20kW output power. The maximum number of blocks per string is 32 blocks per string. The maximum number of strings is three. In EBC-L, it is possible to have up to 64 blocks per string.

The external battery cabinets are equipped with safety shields behind the battery cells. Voltage. Power and control wiring

the cabinets. The battery cabinet can be located freely of the UPS cabinet. All the wiring goes through the back wall of the UPS cabinet.

By default, UPSs are configured to use valve-regulated lead-acid (VRLA) batteries. For the battery specification, see UPS User's and Installation Guide. Should there be a need to connect other type of batteries or other energy storage means, consult a certified and authorized service technician prior to proceeding with installation.

The battery block configuration in the chosen battery cabinet must always match the UPS requirement. Used battery configuration must be inserted into UPS settings during commissioning or start-up. Refer to UPS installation and operation manual for UPS configuration.

Battery cabinet internal power wiring, Battery-to-UPS power wiring and control wiring for integral line-up and match battery cabinets are supplied with both the small and large external battery cabinets.

There is one cable entry in the top-right corner of the back wall of the battery cabinet.

For more information on connecting external battery cabinets to UPS, refer to 93PS UPS 8-40 kW User's and Installation Guide.

### 3.1 Installation checklist

ACTION	YES/NO
All packing materials and restraints are removed from each cabinet.	
Each cabinet in the UPS system is placed in its installed location.	
A cabinet grounding kit / mounting kit is installed between any cabinets that are bolted together.	
All conduits and cables are properly routed to the UPS and any ancillary cabinets.	
All power cables are properly sized and terminated.	
Neutral conductors are installed according to the requirements.	
A ground conductor is properly installed.	
Battery cables are terminated and connected to battery connectors.	
Battery Shunt trip and Aux contact signal wiring is connected from the UPS to the battery breaker.	
Room ventilation and air conditioning equipment is installed and operating correctly.	
The area around the installed UPS system is clean and dust-free (it is	

ACTION
recommended that the UPS is in a room with computer or electronic equipment.
There is adequate workspace around the UPS.
Adequate lighting is provided around the UPS.
A 230 VAC service outlet is located near the UPS equipment.
(OPTIONAL) Alarm relays and signals are connected to the UPS.
(OPTIONAL) A remote battery disconnect switch is installed location and its wiring is connected to the battery cabinet.
(OPTIONAL) Accessories are mounted on the UPS and their wiring is terminated inside the UPS.
Start-up and operational checks are performed by Eaton Customer Service Engineers.

### 3.2 Installation considerations

The battery cabinet installation should be performed by a qualified technician.

- Install the system on a level surface.
- Install the system in a temperature controlled area free of conductive contaminants.

The battery cabinet dimensions are as follows:



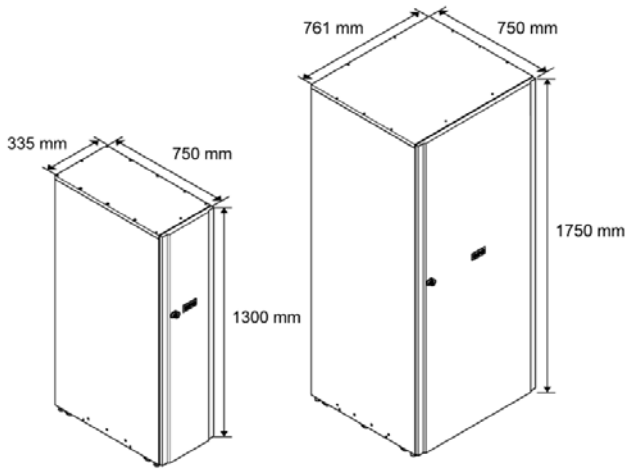

Figure 2. EBC-S and EBC-L dimensions

A DC-rated circuit breaker within each cabinet provides protection and service isolation.

The battery cabinets use convection cooling to regulate internal component temperature. Air inlets are at the bottom of the door and in the large battery cabinet also at the bottom of the back wall and outlets are on the rear of the cabinet. Allow clearance in front and rear of each cabinet for proper air circulation.

The clearance required around the battery cabinet is shown in Table 1.

Table 1. Battery cabinet minimum clearances

	EBC-S	EBC-L
From the top of the cabinet	0 mm	0 mm
From the front of the cabinet	500 mm	800 mm
From the back of the cabinet	150 mm	250 mm
From the side of the cabinet	0 mm	0 mm

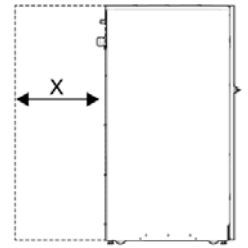

Figure 3. Battery cabinet clearance

- X = clearance at the back

The following molded case circuit breakers are used with the external battery cabinets:

With EBC-S	
With EBC-L	

The following 24V shunt-release circuit breakers are used with the above circuit breakers:

TYPE
NZM1-XAHIVL24AC/DC

### 3.3 Unpacking and unloading the EBC

**WARNING**



The external battery cabinet is heavy. If the unpacking instructions are not closely followed, the cabinet may tip over and cause serious injury.

Do not tilt the cabinet more than 10 degrees from the vertical or the cabinet may tip over.

For transportation purposes, the battery cabinet is bolted onto a wooden pallet. To remove the pallet, perform the following procedure:

<p>1. Before you unload the cabinet from the pallet, use a forklift or other material handling equipment to move the cabinet to the installation area. Insert the forks of the forklift between the skids on the bottom of the unit.</p>	
<p>2. Make a visual inspection and check that there are no signs of shipping damages. Check the indicators. See the instructions next to the indicators on the package.</p>	

3. Open the package. The room the package is used as a ramp for moving the cabinet off the pallet.

4. Place the ramp on the floor, attach it to the pallet with straps or screws so that it can be safely used for wheeling the cabinet off the pallet.

5. If the leveling feet are not retracted, turn them until they are retracted.

6. Open the cabinet door.

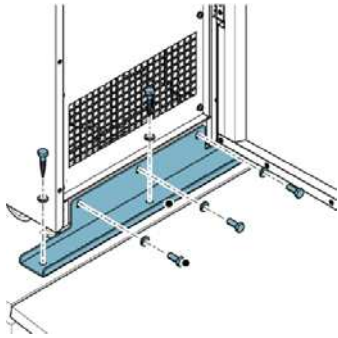
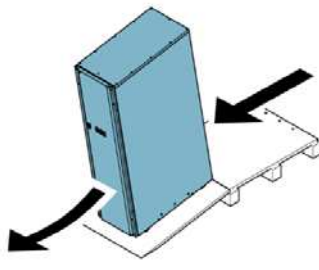
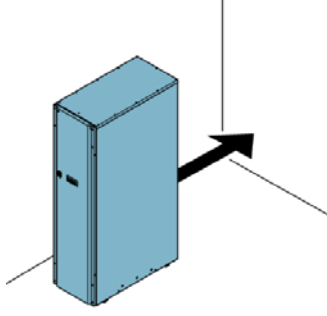
<p>7. Remove the bolts that fasten the shipping brackets to the UPS cabinet and to the pallet.</p> <p>8. Remove the shipping brackets.</p>	
<p>9. Slowly roll the cabinet toward the ramp edge. Be careful not to push the cabinet too much or too fast since it may cause the cabinet to tip over. Note that the cabinet is heavy. Make sure that you have enough manpower to handle and support the unit while rolling it off the pallet.</p>	
<p>10. Roll the cabinet to its final installation location.</p>	

11. To secure the cabinet in position, lower the leveling until the cabinet is not resting on the casters and the cabinet is level.



*NOTE: If you remove the cabinet from its current location, transfer it to a new location on a pallet. The cabinet is not resting on the casters. Do not remove the shipping brackets to the cabinet and the pallet.*

### 3.4 Installing the EBC



Do not connect battery strings in parallel.

Make sure that the UPS with external battery strings is connected to the correct number of strings per string. External battery strings must be connected to the correct number of strings per string.



Make sure that all power sources are disconnected before working on the cabinet.



Always use double insulated wires for connections outside the cabinets. If you use external wires, make sure that the wires provided with the cabinet, match the cross-sectional area of the external wires.

See Figure 4 for terminals and connections.

shunt trip cable terminations.

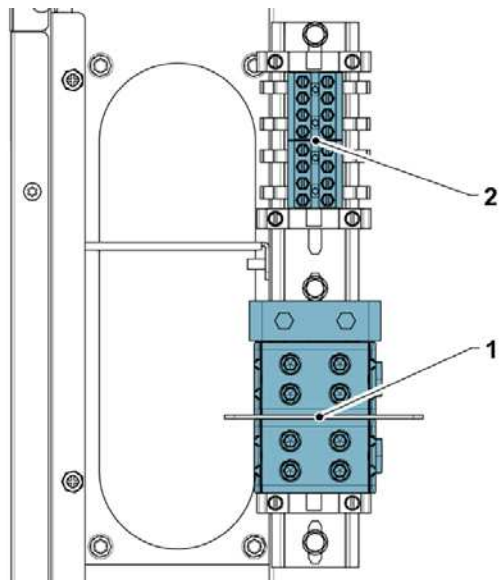

Figure 4. TB1 and TB2 terminals

- 1. Terminal TB1
- 2. Terminal TB2

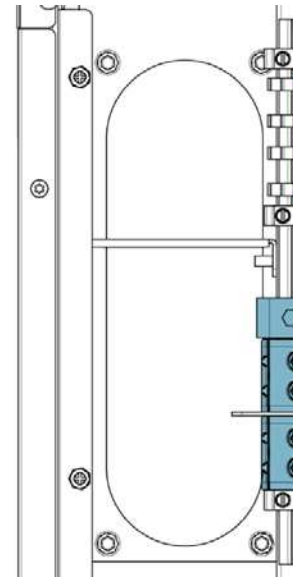
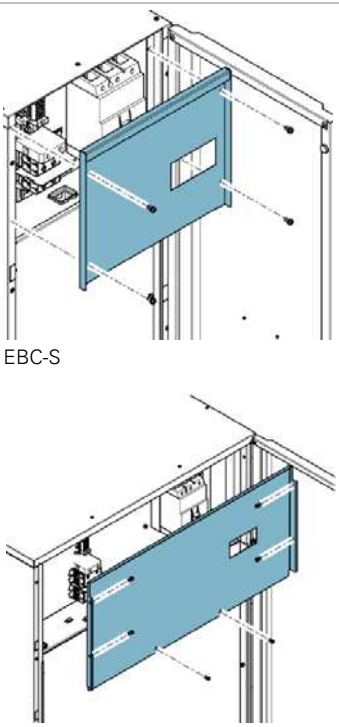
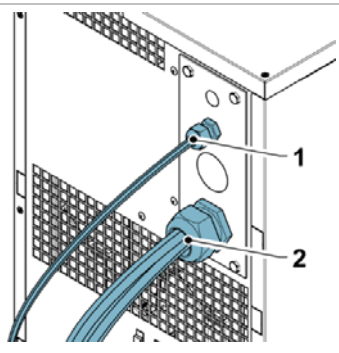

Figure 5. EBC power cable and battery shunt trip cable terminations

- 1. +24V, battery shunt trip cable from UPS
- 2. TRIP, battery shunt trip cable from UPS
- 3. DET, battery shunt trip cable from UPS
- 4. GND, battery shunt trip cable from UPS
- 5. +24V, battery shunt trip cable from another EBC if daisy-chained

To connect the power cables and battery shunt trip cables to the cabinet:

- 1. Open the cabinet door.

<p>2. Open the screws and remove the front panel.</p>	 <p>EBC-S</p> <p>EBC-L</p>
<p>3. Route the signal wires (1) and power cables (2) through the gland plate.</p>	
<p>4. Connect the signal wires and the power cables to the connectors according to Figure 5.</p>	
<p>5. Put the front plate back and fasten the screws.</p>	

If multiple cabinets are used, make sure that the signal wires are connected in the next cabinet.

To daisy chain signal wires, cut the signal wires at the end of the cables and connect the wires to the next cabinet.

### 3.5 Installation compatibility

EBC-S and EBC-L are fully compatible with other UPS models in the line. Other UPSs may not be fully compatible with these cabinets. Refer to the UPS for more information on compatibility.

### 3.6 Operation

To set the cabinet on or off, open the power switch down or up. See Figure 6.

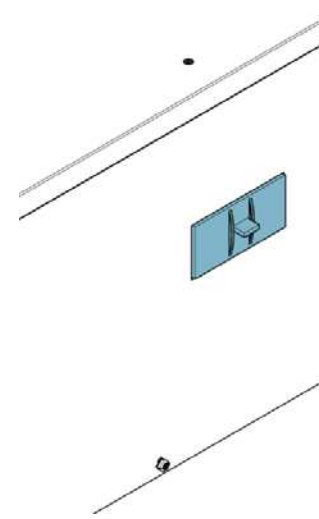

Figure 6. The power switch

## 4 Maintenance

The components inside the cabinet are secured to a sturdy metal frame. All repairable parts and assemblies are located for easy removal with very little disassembly. This design allows authorized service personnel to perform routine maintenance and servicing quickly. Schedule periodic performance checks of your UPS system to keep it running properly. Regular routine checks of the operation and system parameters enable your system to function efficiently for many trouble-free years.

### 4.1 Important safety instructions

Remember that your UPS system is designed to supply power **EVEN WHEN IT IS DISCONNECTED FROM THE UTILITY POWER**. The UPS module interiors are unsafe until the DC power source is disconnected and the electrolytic capacitors are discharged.

After disconnecting the utility power and the DC power, authorized service personnel must wait at least 5 minutes for capacitor bleed-off before attempting internal access to the UPS module.

#### DANGER



**LETHAL VOLTAGE.** Do not operate the UPS system without the cabinet doors or protective panels secured. Do not make any assumptions about the electrical state of any cabinet in the UPS system.

#### WARNING



All service and maintenance work must be performed only by service personnel qualified and authorized by Eaton.

Since each battery string is an energy source in itself, opening the battery circuit breaker does not de-energize the voltage within the battery string.



Do not attempt to access any internal components yourself. Voltages are always present. Always suspect that a battery string is energized. Consult a representative.

Observe these precautions when working on the battery cabinets:

- Remove watches, rings, and jewelry.
- Use tools with insulated handles.
- Wear rubber gloves and boots.
- Do not lay tools or metal parts on the battery cabinets.
- Prior to connecting or disconnecting the battery from a charging source.
- Determine if the battery is grounded to the source of the ground. If the battery is not grounded, a battery can result in an electrical shock. The electrical shock is reduced if such a ground connection is made and maintenance.
- When replacing batteries, always use the same type of batteries.
- Dispose of batteries according to local regulations and requirements.

### 4.2 Performing preventive maintenance

The battery cabinets require preventive maintenance. However, inspect the system regularly to ensure it is operating normally and that there are no signs of damage.

#### 4.2.1 Periodic maintenance

Inspect the UPS periodically to ensure that all connections exhibit evidence of proper torque on bolted connections.

**4.2.2 Annual maintenance**

**CAUTION**



Only authorized personnel that are familiar with the maintenance and servicing of the UPS system are allowed to perform annual preventive maintenance. Contact your service representative for more information about service offerings.

**4.2.3 Battery maintenance**

**WARNING**



Only authorized personnel are allowed to perform battery replacement and maintenance. Contact your service representative for battery maintenance.

**4.3 Recycling the used UPS or batteries**

Remove the battery bank before disposing of the UPS or its battery cabinet. Follow the local requirements regarding battery recycling or disposal.

**WARNING**



Only authorized personnel are allowed to remove the batteries due to the risk caused by high energy and voltage.

Do not discard waste electrical or electronic equipment in the trash. For proper disposal, contact your local collecting/recycling/reuse or hazardous waste center and follow the local legislation.

The following symbols indicate a product requiring special handling:



Figure 7. WEEE symbol



Figure 8. Recycling batteries symbol

When handling waste from electrical and electronic equipment, contact your local collecting centers.

**⚠ WARNING****HAZARDOUS MATERIALS.**

Batteries may contain high voltages and caustic, toxic and flammable substances. If used improperly, batteries can injure or kill people and damage equipment.



Do not discard of unwanted batteries or battery material in the public waste disposal system. Follow all the applicable local regulations regarding the storage, handling and disposal of batteries and battery materials.

**4.4 Maintenance training**

For more information about training and other services, contact your Eaton representative.

**5 Technical data**

For a complete technical specification, contact your Eaton representative. Due to continuous product development, specifications are subject to change without notice.

**5.1 Standards**

Safety

Performance &amp; tests

Environmental

RoHS

WEEE

ECO Design Directive

Batteries

Packaging



## 5.2 Battery specification

Battery type	VRLA, 12 VDC
Battery quantity	32 blocks, 192 cells per battery string <b>Note!</b> Do not connect battery strings with different battery quantity and voltage in parallel!
Battery voltage	384 V (32 blocks)

## 5.3 Environmental specifications

Recommended storage temperature range	From -25 °C to +25 °C in the protective package
Ambient operating temperature range	From 0 °C to +40 °C
Recommended operating temperature range	From +20 °C to +25 °C
Relative humidity range	5 to 95%, no condensation allowed

# 6 Warranty

## 6.1 General

The product is warranted against material and workmanship for a period of twelve (12) months. Your local office or distributor may provide more details above. Please refer to local terms and conditions of the contract.

The UPS manufacturer is not responsible for:

- Any costs resulting from a repair, alternation, or ambient conditions that do not fulfill the requirements specified in the manual with the unit and other related equipment.
- Equipment subjected to misuse or abuse.
- Equipment comprised of non-Eaton parts supplied by the purchaser.

The warranty is only valid if the installation and testing of the UPS unit is carried out by a qualified technician. Service and maintenance of the unit must be performed by a service engineer approved by Eaton. Otherwise, the warranty is voided.

If the product fails to meet its specifications due to material and workmanship, Eaton will repair or replace the warranted component. The repair or replacement must be made by Eaton or by a service engineer approved by Eaton. Replacement during the warranty period is free of charge. Warranty does not cover damage caused by connection with replacement components.

Batteries are warranted against failure due to material and workmanship, not against the normal aging and capacity loss. A poor product storage environment or a poor installation may lead to failure to do this will cause the warranty to be voided.

Under no circumstances shall the manufacturer, its suppliers or subcontractors be liable for special, indirect, incidental or consequential damages, losses or penalties.

The technical data, information and specifications are valid at the time of printing. The UPS manufacturer reserves the right to modifications without prior notice.

## **6.2 Whom to contact in case of Warranty**

In case of Warranty, or while unsure if the unit in question is covered by warranty, contact the respective sales organization where the unit was purchased. Have the following information available:

- Purchase order number and purchase order date
- Installation date
- OR
- Serial number and part number of the unit (information available on the unit's label)



Eaton Power Quality Oy  
Koskelontie 13  
FI-02920 Espoo  
Finland  
[www.eaton.eu](http://www.eaton.eu)

Copyright © 2015 Eaton Corporation plc. All rights reserved. Unauthorized copying and lending are prohibited.