



ИБП Eaton PW 9315-100 - Модуль сервисного байпаса для Powerware 9315 30 -160 кВА - Руководство

Постоянная ссылка на страницу: <https://eaton-power.ru/catalog/powerware-9315/pw-9315-100/>



POWERWARE[®] 9315

Maintenance Bypass Module 30-160kVA

Installation/Operation Manual

164201177 Rev. C

IMPORTANT SAFETY INSTRUCTIONS

Instructions Importantes Concernant La Sécurité

SAVE THESE INSTRUCTIONS

Conserver Ces Instructions

This manual contains important instructions for your Uninterruptible Power Supply (UPS) system. You should follow these instructions during the installation and maintenance of the UPS, options, accessories, and batteries.

Cette notice contient des instructions importantes concernant la sécurité.

This equipment has been tested and found to comply with the limits for a Class A digital device, pursuant to Part 15 of the FCC Rules. These limits are designed to provide reasonable protection against harmful interference when the equipment is operated in a commercial environment. This equipment generates, uses, and can radiate radio frequency energy and, if not installed and used in accordance with the instruction manual, may cause harmful interference to radio communications. Operation of this equipment in a residential area is likely to cause harmful interference in which case the user will be required to correct the interference at their own expense.

WARNING:

This is a product for restricted sales distribution to informed partners. Installation restrictions or additional measures may be needed to prevent disturbances.

Table of Contents

1 Introduction	1
Using This Manual	2
Conventions Used in This Manual	2
For More Information	3
Getting Help	3
2 Getting Started	5
Preparing the Site	6
Creating an Installation Plan	6
Environmental Considerations	6
Preparing for Wiring the Maintenance Bypass Module	6
Inspecting and Unpacking the Maintenance Bypass Module	7
Unloading the MBM from the Pallet	9
3 Installing and Wiring the Maintenance Bypass Module	11
Line and Load Wiring	13
4 Maintenance Bypass Module Operation	15
Preliminary Checks and Startup for UPS Equipped with Maintenance Bypass Module	15
Maintenance Bypass Module Operation	15
MBM Operation Without Kirk Key Interlocks	16
MBM Operation With Kirk Key Interlocks (Optional)	17
Kirk Key Solenoid Release Unit (SKRU)	17
MBM Transfer Sequences	17
Maintenance	19
Short Circuits	19
Maintenance Bypass Module Diagrams	19
Appendix A	A-1

List of Figures

Figure 1.	Typical 30–160kVA MBM with Isolation Transformer	1
Figure 2.	Front and Side View of Typical Maintenance Bypass Module on Shipping Pallet (30–160kVA w/XFMR)	5
Figure 3.	MBM as Shipped, with Outer Packaging and Pallet	7
Figure 4.	Detail of Shipping Supports	10
Figure 5.	Top, Bottom, and Front View of Maintenance Bypass Module (30–160kVA w/XFMR)	11
Figure 6.	Typical Power Wiring Terminations of UPS Module and Maintenance Bypass Module (30–160kVA)	13

1

Introduction

The Powerware 9315 Maintenance Bypass Module (MBM) is a floor-mounted, enclosed cabinet containing a UPS module, Maintenance Isolation circuit breaker (MIS), and a maintenance Bypass circuit breaker (MBP). An optional UPS Module Input Bypass circuit breaker (BIB) is available. The MBM can be either free-standing or line-up-and-match. Figure 1 shows a typical MBM cabinet with isolation transformer for a Powerware 9315 30–160kVA UPS and MBM cabinet without isolation transformer for a Powerware 9315 30–160kVA UPS.

The equipment and devices described in this manual are provided for operation with the specific UPS Modules (model and rating) described in the appendix.

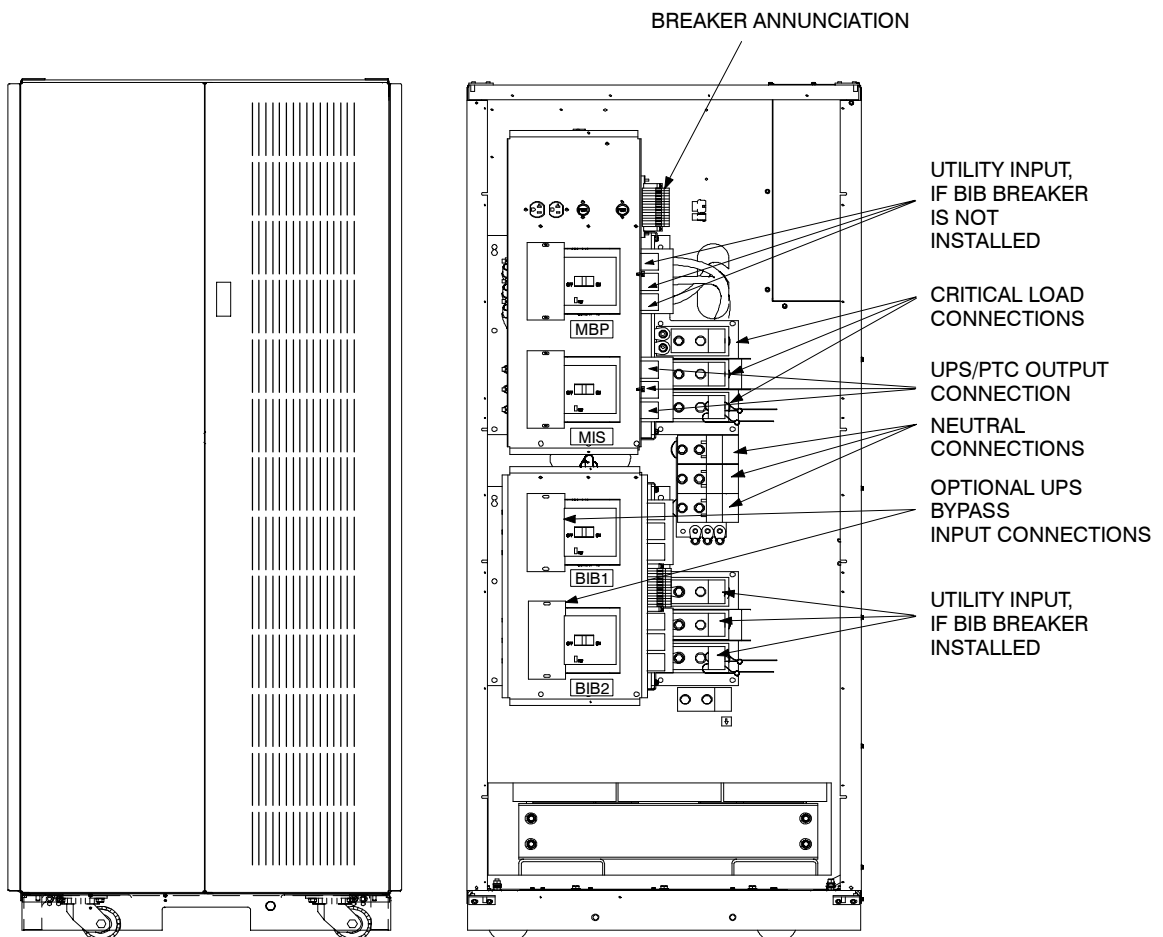

Figure 1. Typical 30–160kVA MBM with or without Isolation Transformer.

Using This Manual

This manual contains installation and operation procedures for the MBM. Before installation and operation, read through each procedure.

- Chapter 1 provides an overview of this manual and references for further information.
- Chapter 2 tells you how to prepare your site for the installation of the MBM. It discusses equipment environmental requirements, inspecting, and unpacking cabinets.
- Chapter 3 describes how to install the MBM cabinet.
- Chapter 4 contains operating information for the MBM.
- Appendix A contains important information for planning and installing the MBM, including wiring data and illustrations of cabinets.

Conventions Used in This Manual

This manual contains installation and operation procedures for the Maintenance Bypass module.

- **Bold type** highlights important concepts in discussions, key terms in procedures, and menu options.
- *Italic type* highlights notes, references to other system manuals, references to other sections of this manual, and new terms where they are defined.
- Rectangular boxes containing bold type are warnings or cautions that pertain to the system or its electrical connections. This important information indicates possible dangers pertaining to personnel safety, equipment damage, critical load protection, or operational concerns.

For More Information

For more information on the installation and operation of the UPS system and its accessories, refer to the following:

164200252 *Powerware® 9315 30–160 kVA UPS Operation*

Each manual describes the UPS cabinet, Control Panel, and Monitor Panel, and explains the functions of the UPS; discusses the standard features of the UPS and optional accessories; provides procedures for starting and stopping the UPS, and information about maintenance and responding to system events.

These also describe the RS–485 and RS–232 serial communications capabilities of the UPS system; discuss the two communications ports on the Customer Interface Panel inside the UPS and how to connect optional remote accessories to your UPS system; and provide information about enabling, disabling, and customizing building alarms.

164200253 *Powerware® 9315 30–80 kVA UPS Installation*

164200292 *Powerware® 9315 100–160 kVA UPS Installation*

Each manual contains the following information: how to prepare the site and plan for installation, detailed step-by-step procedures for installing each component of your system, how to join cabinets in a line-up-and-match system, detailed illustrations of cabinets and optional accessories, including dimensions and connection points.

Contact the local Powerware Field Service office for information on how to obtain copies of these manuals.

Getting Help

If you have a question about any of the information in this manual, or if you have a question this manual does not answer, please call Powerware Field Service:

United States	1-800-843-9433
Canada	1-800-461-9166
Outside the U.S.	Call your local representative

This Page Intentionally Left Blank.

2

Getting Started

This section describes how to install the Powerware 9315 Maintenance Bypass Module (MBM). It contains instructions for installing the MBM and basic site preparation procedures. Figure 2 shows the front and side view of the MBM with or without transformer for a Powerware 9315 30–160kVA module.

The MBM is shipped as a separate item. Use a forklift or pallet jack to move the packaged cabinet to the installation site, or as close as possible to the site, before unloading.

The basic sequence of the installation steps is:

1. Prepare the site for the MBM installation.
2. Inspect, unpack, and unload the MBM.
3. Create an installation plan for wiring the MBM to the UPS system.
4. Prepare for wiring.
5. Complete the installation checklist from the *Powerware® 9315 Installation* manual.
6. Have authorized service personnel perform preliminary checks and startup.

NOTE: *Startup and operational checks should be performed only by authorized service personnel. This service is usually offered as part of the sales contract for your UPS system.*

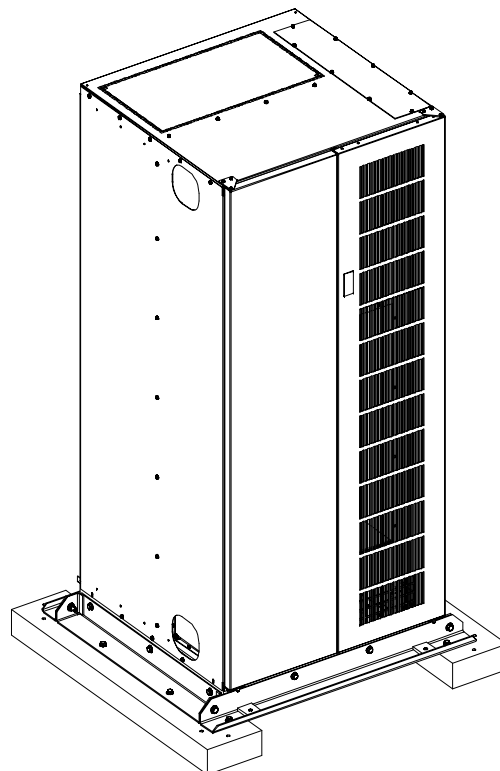

Figure 2. Front and Side View of Typical Maintenance Bypass Module on Shipping Pallet (30–160kVA with or without XFMR)

Preparing the Site

For the MBM to operate at peak efficiency, the installation site should meet the environmental parameters outlined in the *Powerware® 9315 Operation* manual provided with the UPS system. The operating environment must meet the size and weight requirements supplied in the *Powerware® 9315 Installation* manual provided with the UPS system. If the MBM is to be operated at an altitude higher than 1500 meters (5000 feet), contact the local sales or service office for important information about high altitude operation.

The basic environmental requirements for operation of the MBM are:

Ambient Temperature Range	0–40°C (32–104°F)
Recommended Operating Range	20–25°C (68–77°F)
Maximum Relative Humidity	95%

The MBM uses convection cooling to regulate internal component temperature. Air inlets are in the front of the cabinet, and outlets are in the top. Clearance in front of and above each cabinet for proper air circulation is essential.

Creating an Installation Plan

Before beginning to install the MBM, read and understand how this manual applies to the system being installed. It is important to note that UPS module installation procedures are contained in the *Powerware® 9315 Installation* manual provided with the UPS system. It is recommended to first understand how to install the UPS modules. The information in Chapter 2 of this manual is a guide for installation of the MBM to the UPS modules.

Environmental Considerations

The life of the maintenance bypass module is adversely affected if the installation does not meet the following guidelines:

1. The MBM must be installed on a sealed concrete pad or floor.
2. The MBM must be installed in a dust-free environment.
3. The MBM must be installed in a humidity-controlled environment.

Preparing for Wiring the Maintenance Bypass Module

See Tables A-1 through A-6 in Appendix A of this manual for wiring requirements. The power wiring for this equipment is rated at 90°C. If wire is run in an ambient temperature greater than 30°C, higher temperature rating and/or larger size wire may be necessary. Wiring should be installed through the bottom or top entry of the module. For UPS external wiring requirements, including minimum AWG size of external wiring, see the *Powerware® 9315 Installation* manual provided with the UPS system.

NOTE: *Material and labor for external wiring are to be provided by designated personnel.*

Inspecting and Unpacking the Maintenance Bypass Module

The first task in preparing for installation of the MBM is inspecting and unpacking the unit. The MBM arrives covered with protective packaging material as shown in Figure 3.

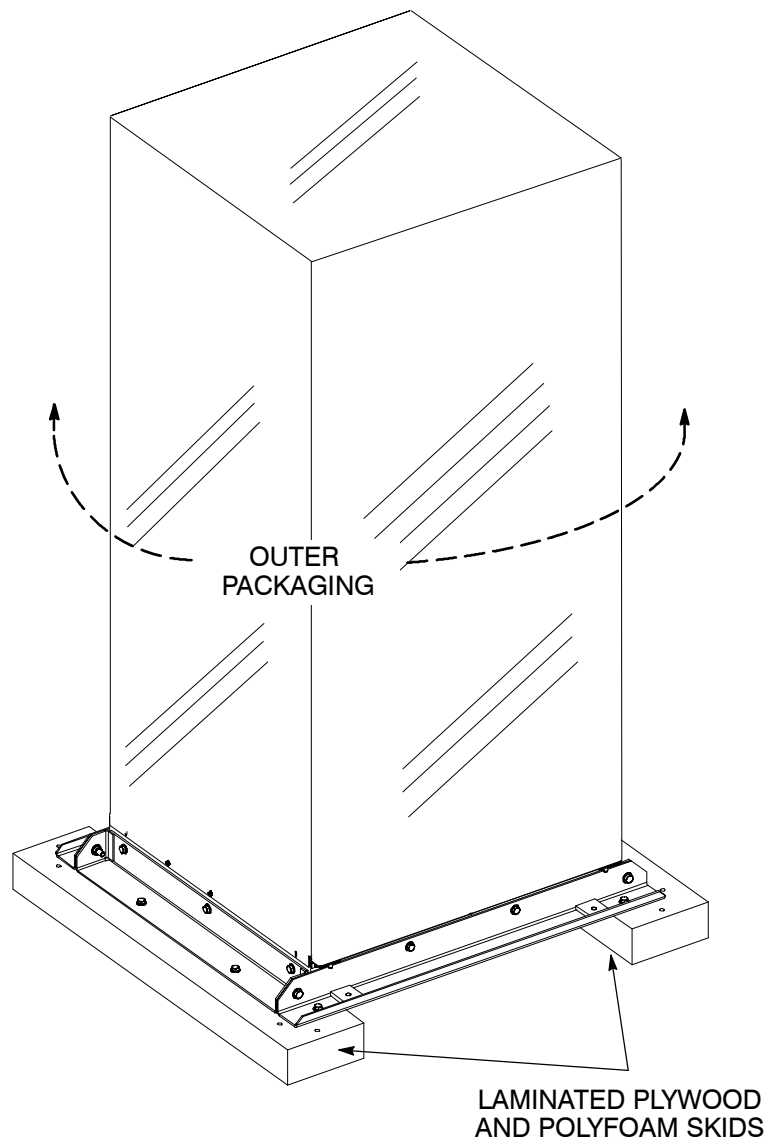

Figure 3. MBM as Shipped, with Outer Packaging and Pallet

1. Carefully inspect the outer packaging for evidence of damage during transit.

CAUTION:

Do not install a damaged MBM. Report any damage to the carrier and contact the local sales or service office immediately.

2. Use a forklift or other material handling equipment to move the MBM to a convenient unpacking area. Insert the forklift jacks between the laminated plywood/polyfoam skids on the bottom of the unit.

CAUTION:

Do not tilt unit more than 10 degrees from vertical.

3. Set the pallet on a firm, level surface, allowing a minimum clearance of 4.6m (15 ft) on each side for removing the MBM from the pallet.
4. Cut the steel bands around the MBM.
5. Remove the protective cardboard covering from the MBM, cutting where indicated, using a knife blade no longer than 25 mm (1 in.).

NOTE: *Do not discard the packaging material. Instructions for unloading the MBM from the pallet are printed on the cardboard. Please to refer to them.*

6. Remove the plastic bag and foam packing material. Please discard or recycle them in a responsible manner.

Unloading the MBM from the Pallet

The MBM pallet consists of four metal angle supports secured to plywood/polyfoam laminated skids. The skids act as shock absorbers for the MBM during shipment.

WARNING:

Unit is extremely heavy. If unloading instructions are not closely followed, the unit may tip and cause serious injury.

Turning the jacking bolts unevenly may cause the unit to become unbalanced. To prevent tipping, raise and lower the jacking bolts evenly and sequentially. The unit should only be raised approximately 3 mm (1/8 in.) above the floor (just enough to remove polyfoam skids).

1. Remove the doors. Remove the retaining screw located inside each door at the bottom hinge pivot point, then lift off the door. Save the retaining screws for reinstallation of the doors.
2. Locate the field kit packed inside the unit. Locate the four 1/2-in. jacking bolts and install them in the threaded holes in the front and rear supports. Place a floor protector underneath each jacking bolt, and screw the bolts down until they contact the floor protectors. The floor protectors prevent the floor from being damaged by the jacking bolts.

WARNING:

Module may fall. Do not loosen hardware attaching the side or front/rear shipping supports to the module base. Also, do not loosen the shipping supports from each other. The module must be lowered using jacking bolts before the shipping supports can be removed.

3. Loosen, but do not remove the hardware holding the plywood/polyfoam skids to the front and rear supports (labeled "1" in Figure 4 – 8 places).
4. Turn each jacking bolt clockwise sequentially, no more than two full turns each, until the foam cushions clear the floor by approximately 3 mm (1/8 in.).
5. After the plywood/polyfoam skids clear the floor, remove the hardware loosened in step 3. Pull the skids out from under the MBM. Discard or recycle them in a responsible manner.

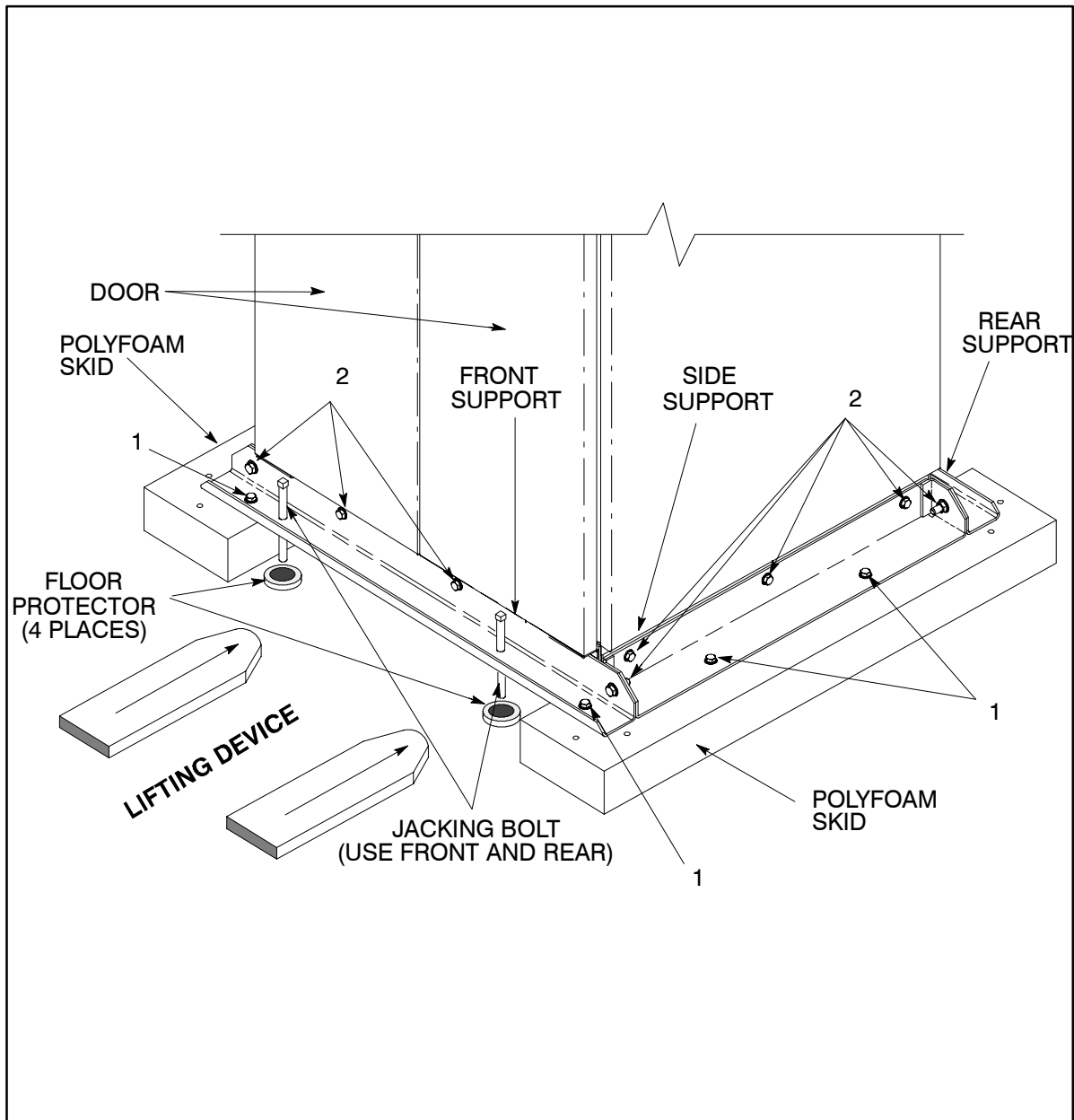

Figure 4. Detail of Shipping Supports

6. Carefully and evenly lower the MBM by turning each jacking bolt counterclockwise in sequence no more than two full turns each (maximum) until the supports contact the floor, and the module is no longer supported by the jacking bolts.
7. When the module is resting on the floor, remove the jacking bolts. Discard or recycle them in a responsible manner.
8. Remove the hardware labeled “2” in Figure 4, holding the front, rear and side supports to the module base (14 places). Discard or recycle the hardware and support brackets in a responsible manner.
9. Install the doors removed in step 1. The MBM is now ready to be rolled to its final location.

3

Installing and Wiring the Maintenance Bypass Module

When the maintenance bypass module (MBM) has been moved to its installed location, unpacked, and inspected, it is ready for installation. This section discusses the typical process of installing the MBM in both the line-up and match and free-standing situations. The MBM is shown in Figure 5.

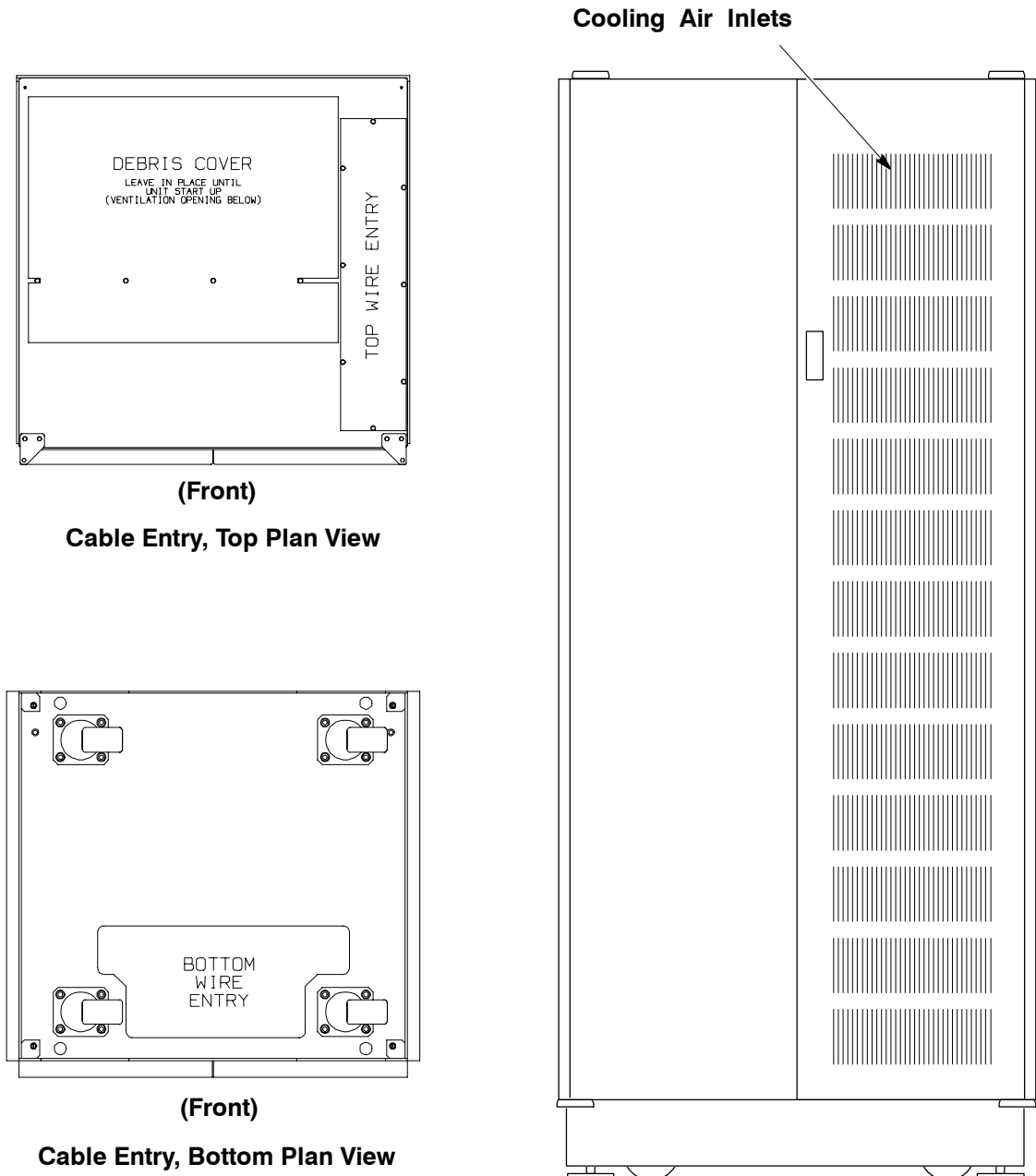

Figure 5. Top, Bottom, and Front View of Maintenance Bypass Module (30–160kVA with or without XFMR)

Refer to the following while installing the MBM:

- Dimensions in this manual are in millimeters and (inches).
- Do not tilt the unit more than $\pm 10^\circ$ during installation.
- Remove the conduit landing plates to add conduit landing holes as required. Plate material is 16 gauge steel (0.06 in. thick).
- Terminals are UL and CSA rated at 90°C . A hex key tool is required to attach wires to the terminals.
- Details about power wiring are provided in the tables of Appendix A of this manual.

Figure 6 shows typical power wiring terminations of the UPS module and Maintenance Bypass Module (30–160kVA). Refer to the Powerware 9315 Installation manual provided with the UPS system for location of UPS module cabinet wiring terminations.

NOTE: Material and labor for external wiring are to be provided by designated personnel.

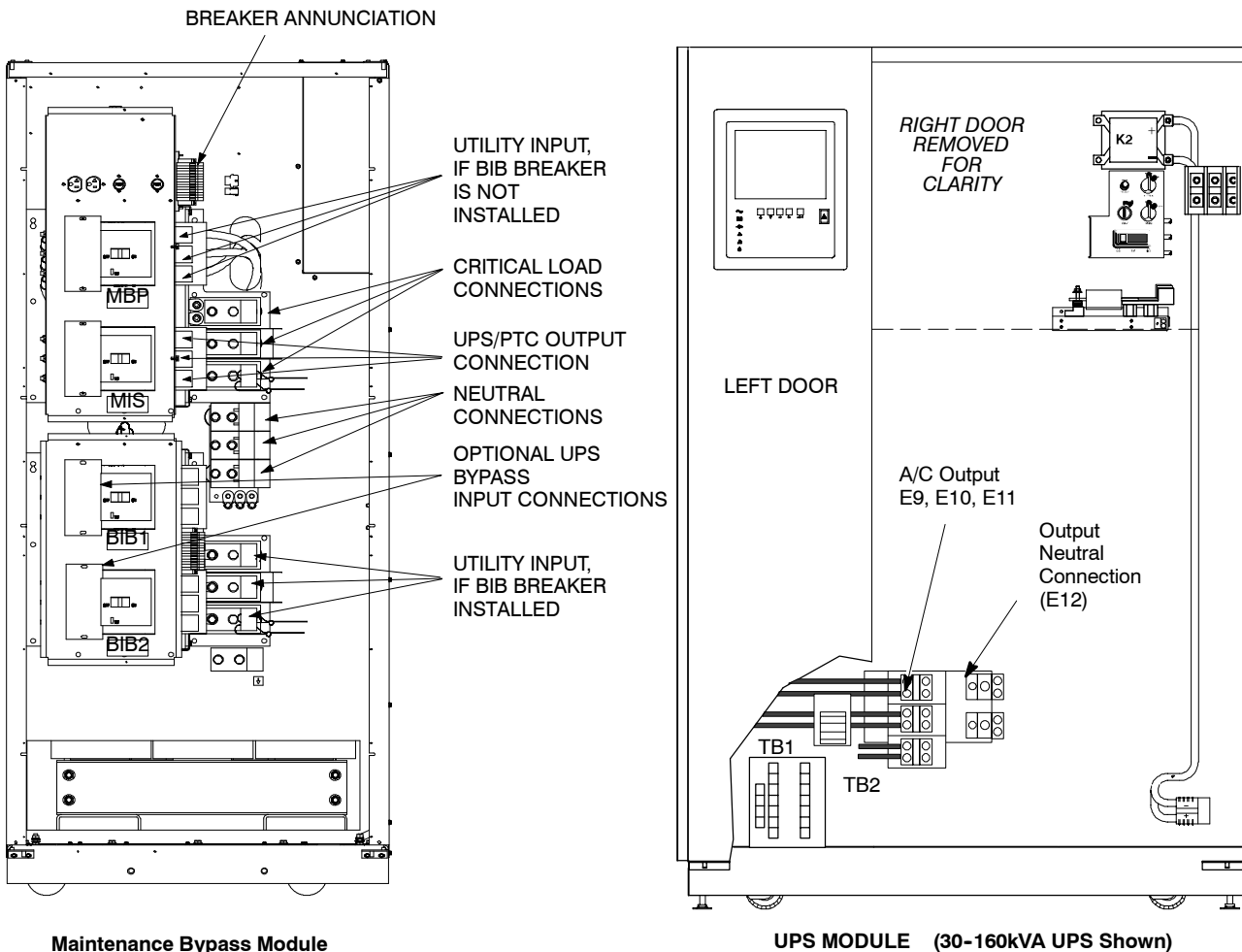

Figure 6. Typical Power Wiring Terminations of UPS Module and Maintenance Bypass Module (30–160kVA)

The recommended location, for the Maintenance Bypass Module, is as close to the installed UPS module as possible. Refer to the tables in Appendix A for wire rating and sizing information

The MBM is packaged in a module similar to the UPS modules (same height, width, depth). The MBM is designed as a standard line-up-and-match accessory for the 30–160 KVA rated modules.

Wiring harness assemblies for connecting the UPS module bypass input and output to the MBP are provided in separate shipping containers, if applicable. The wiring harness assemblies are passed through the 3-inch wiring feed-through hole located at the lower right side of the MBM cabinet, for connecting to the UPS input and output terminals. Refer to Appendix A for UPS module to MBM wiring terminal locations.

Line up and match connection (cables sold separately by Powerware)

- From the UPS to the MBM, the power cables are connected by mechanical pressure lugs.
- From the UPS to the MBM, the control cables are connected to terminal blocks.

Remote connection (cables, lugs, and hardware supplied by others)

- All cables are terminated to MBM mechanical pressure lugs.

Line and Load Wiring

The Maintenance Bypass Module provides a means to manually transfer the Critical load from the UPS module via the UPS Module Bypass to a Maintenance Bypass Module as may be necessary for shutting down the UPS Module for maintenance or testing. The proper operation of the transfer is accomplished without interrupting the load power.

The UPS Module Bypass AC Input and the Maintenance Bypass AC Input must be from the same or synchronized AC sources. The UPS Module Bypass Input is connected through the MBP cabinet via an optional Bypass Input Breaker (BIB), if installed. The Maintenance Bypass Breaker (MBP) is placed in the secondary of the stepdown transformer (480:208 VAC or 600:208 VAC) or connected directly to the Maintenance Bypass source if the Isolation Transformer is not required.

UPS Module AC output connects through the MBM cabinet via isolation breaker MIS. Critical Load terminals are located on the load side of breakers MBP and MIS.

The Critical Load may be transferred in a Make-Before-Break transfer sequence between the UPS Bypass Source and the Maintenance Bypass source after UPS output has been transferred from the UPS module and UPS bypass operating mode. The MBP must first be closed to prevent power interruption and MIS opened to provide UPS isolation from the Critical Load bus. Refer to the Transfer Sequence placard affixed to the front of the MBM cabinet.

This Page Intentionally Left Blank.

4 Maintenance Bypass Module Operation

This chapter provides preliminary checks, maintenance operations and a schematic diagram of the maintenance bypass module.

Preliminary Checks and Startup for UPS Equipped with Maintenance Bypass Module (MBM)

Installation inspection and startup procedures must be performed only by a Powerware Corporation authorized service person. The procedure is normally part of the sales contract for the UPS system.

WARNING:

Attempts to startup the UPS system yourself may damage equipment and/or your critical load. Such attempts may also invalidate your system warranty.

Maintenance Bypass Module Operation

The MBM is provided for use with the Powerware 9315 (30–160kVA) UPS module.

WARNING:

Only persons familiar with the operation of this equipment should transfer loads. Failure to follow the transfer sequence exactly may cause loss of power to the critical load or may cause overload protection devices to function.

Operator Note:

MIS is to be OPENED *only* after MBP is CLOSED

MBP is to be OPENED *only* after MIS is CLOSED

MBM Operation Without Kirk Key Interlocks

The following transfer sequence is the recommended procedure for the step-by-step load transfer from and back to the UPS when required. This information is provided on a label located on the deadfront panel behind the right front door of the MBM.

From UPS Bypass to Maintenance Bypass:

1. Confirm BIBs, if installed, are closed.
2. Transfer UPS from Normal to Bypass mode (see UPS Operation manual).
NOTE: For Parallel Redundant systems, transfer both UPS modules to Bypass mode.
3. Close MBP breaker.

CAUTION:
Failure to close MBP breaker results in loss of power to the critical load.

4. Open MIS breaker.
5. Deenergize UPS before servicing unit (see UPS operation manual).

CAUTION:
For UPS electrical isolation, BIB breaker (if applicable) must be opened.

From Maintenance Bypass to UPS Bypass:

1. Confirm BIBs, if installed, are closed.
2. Transfer UPS from Normal to Bypass mode (see UPS Operation manual).
NOTE: For Parallel Redundant systems, transfer both UPS modules to Bypass mode.
3. Close MIS breaker.

CAUTION:
Failure to close MIS breaker results in loss of power to the critical load.

4. Open MBP breaker.
5. To place UPS in Normal Mode, see UPS operation manual.

NOTE: While the UPS is in Normal Mode and the MIS breaker is closed, the MBP breaker always trips OFF. Likewise, while the UPS is in Normal Mode and the MBP is closed, the MIS breaker always trips OFF.

MBM Operation With Kirk Key Interlocks (Optional)

The following transfer sequence is the recommended procedure for the step-by-step load transfer from and back to the UPS when required. This information is provided on a label located on the deadfront panel behind the right front door of the MBM.

Kirk Key Solenoid Release Unit (SKRU)

The 120 VAC operating power for the Kirk Key Solenoid Release Unit (SKRU) is derived from the Maintenance Bypass source.

The Kirk Key SKRU is provided to prevent access to the key, which is necessary to initiate the transfer sequence. The operator must observe the instructions on the Transfer Sequence nameplate mounted on the MBP Panelboard.

Electrical interlocks inhibit key release until UPS is in the Bypass mode.

MBM Transfer Sequences

From UPS Bypass to Maintenance Bypass:

1. Confirm BIBs, if installed, are closed.
2. Transfer UPS from Normal to Bypass mode (see UPS Operation manual).
NOTE: For Parallel Redundant systems, transfer both UPS modules to Bypass mode.
3. Depress pushbutton on the solenoid key release unit (SKRU). Turn and remove key "A". Key "A" may be removed when UPS system is in Bypass mode as indicated by illuminated pilot light.
4. Insert key "A" into MBP lock, retract bolt, close MBP breaker. Remove key "B".

CAUTION:
Failure to close MBP breaker results in loss of power to the critical load.

5. Insert key "B" into MIS lock, open MIS breaker, extend bolt. Remove key "A".
6. Insert key "A" into solenoid and turn key to LOCK position.
7. Deenergize UPS before servicing (see UPS Operation manual).

CAUTION:
For UPS electrical isolation, BIB breaker (if applicable) must be opened.

From Maintenance Bypass to UPS Bypass:

1. Confirm BIBs, if installed, are closed.
2. Transfer UPS to Bypass mode (see UPS Operation manual).
NOTE: For Parallel Redundant systems, transfer both UPS modules to Bypass mode.
3. Depress pushbutton on the Solenoid Key Release Unit (SKRU). Turn and remove key "A".
4. Insert key "A" into MIS lock, retract bolt, close MIS breaker. Remove key "B".

CAUTION:
Failure to close MBP breaker results in loss of power to the critical load.

5. Insert key "B" into MBP lock, open MBP breaker, extend bolt. Remove key "A".
6. Insert key "A" into solenoid and turn key to LOCK position.
7. See UPS Operation manual to place UPS in Normal mode.

WARNING:
Dangerous and potentially lethal voltages are present within the UPS enclosure. When maintenance or repair activities are to be performed, the UPS and the UPS Bypass power sources should be deenergized and verified with a meter before working in the required area.

WARNING:
UPS equipment has power feeds that are derived from two or more power sources.

Maintenance

Maintenance should be scheduled on a periodic basis, recommended not to exceed one year. More frequent intervals are recommended if the equipment is subjected to highly repetitive operations.

CAUTION:

Refer to Section 9 – *Maintaining the UPS System of the Powerware 9315 30–160kVA Operation manual*, Powerware part number 164200252, before beginning maintenance or repairs on the UPS equipment.

WARNING:

Dangerous and life-threatening voltages are present when the UPS is operating. De-energize all equipment before physically touching potentially live parts.

Periodic inspections of the maintenance bypass module should be made to determine if components, wiring, and connections exhibit evidence of overheating. Particular attention should be given to bolted connections. Maintenance procedures should specify that the bolted connections be retorqued to values listed on labels posted on the equipment.

CAUTION:

Overtightening of bolted connections containing compression washers decreases the washer's ability to maintain compression during heating and cooling cycles.

Refer to circuit breaker manufacturer's application and maintenance literature for recommended maintenance practices and procedures.

Short Circuits

Short circuits are not considered normal phenomena in UPS applications. Tripping of protective devices due to low impedance short circuits should be thoroughly investigated for damage to conductors, insulation, and the protective devices in accordance with the manufacturer's recommendations.

Maintenance Bypass Module Diagrams

See Appendix A for onelines and system configuration schematics

This Page Intentionally Left Blank.

Appendix A – Customer Information

The information in this appendix will help you plan for and install your Maintenance Bypass Module cabinet. This appendix contains the following:

- 164201177–1 Installation Notes
- 164201177–2 Typical MBM Cabinet – 30-160kVA with or without XFMR
- 164201177–3 Typical UPS System with MBM
- 164201177–4 Oneline – 30-160kVA, Reverse Transfer (RT), 480:480VAC, 600:600VAC, 400:400VAC
- 164201177–5 Oneline – 30-160kVA, Reverse Transfer (RT), 480:208VAC, 600:208VAC
- 164201177–6 Oneline – 30-160kVA, Reverse Transfer (RT), 208:208VAC,
- 164201177–7 Oneline – 30-160kVA, Parallel, 480:480VAC, 600:600VAC, 400:400VAC
- 164201177–8 Oneline – 30-160kVA, Parallel, 480:208VAC, 600:208VAC
- 164201177–9 Oneline – 30-160kVA, Parallel, 208:208VAC
- 164201177–10 UPS Module Line Up and Match 1 through 3

**Table A-1. Ratings & External Wiring Requirements for Powerware 9315
MBM 30-160kVA, 480:208VAC/600:208VAC**

Rating and External Wiring Requirement		Units	Rating 60 Hz							
Basic unit rating at 0.8 lagging PF load		KVA KW	160 128		130 104		100 80		80 64	
UPS Input Voltage/Bypass Input UPS Output Voltage		VOLTS VOLTS	480 208	600 208	480 208	600 208	408 208	600 208	480 208	600 208
A	AC Input to Maintenance Bypass (3) Phases, (1) Ground	AMPS	192	153	156	125	120	96	96	77
	Conductor Size Number per Phase	AWG/MCM (each)	300 (1)	300 (1)	300 (1)	300 (1)	300 (1)	300 (1)	1 (1)	1 (1)
B	AC Input to UPS Bypass (3) Phases, (1) Ground	AMPS	192	153	156	125	120	96	96	77
	Conductor Size Number per Phase	AWG/MCM (each)	300 (1)	300 (1)	300 (1)	300 (1)	300 (1)	300 (1)	1 (1)	1 (1)
C	AC Output to Critical Load (3) Phases, (1) Neutral, (1) Ground	AMPS	444	444	361	361	278	278	222	222
	Conductor Size Number per Phase	AWG/MCM (each)	400 (2)	400 (2)	400 (2)	400 (2)	400 (2)	400 (2)	300 (1)	300 (1)
D	UPS/PTC Output to MBM Cabinet (MIS) (3) Phases, (1) Neutral, (1) Ground	AMPS	444	444	361	361	278	278	222	222
	Conductor Size Number per Phase	AWG/MCM (each)	400 (2)	400 (2)	400 (2)	400 (2)	400 (2)	400 (2)	300 (1)	300 (1)
E	Control Wiring to UPS (2) Conductors	VOLTS AMPS	120 1	120 1	120 1	120 1	120 1	120 1	120 1	120 1

Basic unit rating at 0.8 lagging PF load		KVA KW	65 52		50 40		40 32		30 24	
UPS Input Voltage/Bypass Input UPS Output Voltage		VOLTS VOLTS	480 208	600 208	480 208	600 208	480 208	600 208	480 208	600 208
A	AC Input to Maintenance Bypass (3) Phases, (1) Ground	AMPS	78	63	60	48	48	38	36	29
	Conductor Size Number per Phase	AWG/MCM (each)	1 (1)	1 (1)	1 (1)	1 (1)	1 (1)	1 (1)	1 (1)	1 (1)
B	AC Input to UPS Bypass (3) Phases, (1) Ground	AMPS	78	63	60	48	48	38	36	29
	Conductor Size Number per Phase	AWG/MCM (each)	1 (1)	1 (1)	1 (1)	1 (1)	1 (1)	1 (1)	1 (1)	1 (1)
C	AC Output to Critical Load (3) Phases, (1) Neutral, (1) Ground	AMPS	180	180	139	139	111	111	83	83
	Conductor Size Number per Phase	AWG/MCM (each)	300 (1)	300 (1)	300 (1)	300 (1)	300 (1)	300 (1)	300 (1)	300 (1)
D	UPS/PTC Output to MBM Cabinet (MIS) (3) Phases, (1) Neutral, (1) Ground	AMPS	180	180	139	139	111	111	83	83
	Conductor Size Number per Phase	AWG/MCM (each)	300 (1)	300 (1)	300 (1)	300 (1)	300 (1)	300 (1)	300 (1)	300 (1)
E	Control Wiring to UPS (2) Conductors	VOLTS AMPS	120 1	120 1	120 1	120 1	120 1	120 1	120 1	120 1

Note: Callout letters **A, B, C, D,** and **E** map to drawing 164201177-5 (Reverse Transfer Connection) and 164201177-8 (Parallel Connection). Read and understand the notes on drawings when planning your installation.

DESCRIPTION:	INSTALLATION NOTES	
DRAWING NO:	164201177-1	SHEET: 1 of 4
REVISION:	C	DATE: 041500

Table A-2. Ratings & External Wiring Requirements for Powerware 9315 MBM 30-160kVA, 480:480VAC/600:600VAC

Rating and External Wiring Requirement		Units	Rating 60 Hz					
Basic unit rating at 0.8 lagging PF load		KVA KW	160 128	130 104	100 80			
UPS Input Voltage/Bypass Input UPS Output Voltage		VOLTS VOLTS	480 480	600 600	480 480	600 600	480 480	600 600
A	AC Input to Maintenance Bypass (3) Phases, (1) Ground	AMPS	192	153	156	125	120	96
	Conductor Size Number per Phase	AWG/MCM (each)	300 (1)	300 (1)	300 (1)	300 (1)	300 (1)	300 (1)
B	AC Input to UPS Bypass (3) Phases, (1) Ground	AMPS	192	153	156	125	120	96
	Conductor Size Number per Phase	AWG/MCM (each)	300 (1)	300 (1)	300 (1)	300 (1)	300 (1)	300 (1)
C	AC Output to Critical Load (3) Phases, (1) Neutral, (1) Ground	AMPS	192	153	156	125	120	96
	Conductor Size Number per Phase	AWG/MCM (each)	300 (1)	300 (1)	300 (1)	300 (1)	300 (1)	300 (1)
D	UPS/PTC Output to MBM Cabinet (MIS) (3) Phases, (1) Neutral, (1) Ground	AMPS	192	153	156	125	120	96
	Conductor Size Number per Phase	AWG/MCM (each)	300 (1)	300 (1)	300 (1)	300 (1)	300 (1)	300 (1)
E	Control Wiring to UPS (2) Conductors	VOLTS	120	120	120	120	120	120
		AMPS	1	1	1	1	1	1

Basic unit rating at 0.8 lagging PF load		KVA KW	80 64	65 52	50 40	40 32	30 24
UPS Input Voltage/Bypass Input UPS Output Voltage		VOLTS VOLTS	480 480	480 480	480 480	480 480	480 480
A	AC Input to Maintenance Bypass (3) Phases, (1) Ground	AMPS	96	78	60	48	36
	Conductor Size Number per Phase	AWG/MCM (each)	1 (1)	1 (1)	1 (1)	1 (1)	1 (1)
B	AC Input to UPS Bypass (3) Phases, (1) Ground	AMPS	96	78	60	48	36
	Conductor Size Number per Phase	AWG/MCM (each)	1 (1)	1 (1)	1 (1)	1 (1)	1 (1)
C	AC Output to Critical Load (3) Phases, (1) Neutral, (1) Ground	AMPS	96	78	60	48	36
	Conductor Size Number per Phase	AWG/MCM (each)	1 (1)	1 (1)	1 (1)	1 (1)	1 (1)
D	UPS/PTC Output to MBM Cabinet (MIS) (3) Phases, (1) Neutral, (1) Ground	AMPS	96	78	60	48	36
	Conductor Size Number per Phase	AWG/MCM (each)	1 (1)	1 (1)	1 (1)	1 (1)	1 (1)
E	Control Wiring to UPS (2) Conductors	VOLTS	120	120	120	120	120
		AMPS	1	1	1	1	1

Note: Callout letters **A, B, C, D,** and **E** Map to drawing 164201177-4 (Reverse Transfer Connection) and 164201177-7 (Parallel Connection). Read and understand the notes on drawings when planning your installation.

DESCRIPTION:	INSTALLATION NOTES	
DRAWING NO:	164201177-1	SHEET: 2 of 4
REVISION: C	DATE: 041500	

**Table A-3. Ratings & External Wiring Requirements for Powerware 9315
MBM 30-160kVA, 208:208VAC**

Rating and External Wiring Requirement		Units	Rating 60 Hz							
Basic unit rating at 0.8 lagging PF load		KVA KW	160 128	130 104	100 80	80 64	65 52	50 40	40 32	30 24
UPS Input Voltage/Bypass Input UPS Output Voltage		VOLTS VOLTS	208 208	208 208	208 208	208 208	208 208	208 208	208 208	208 208
A	AC Input to Maintenance Bypass (3) Phases, (1) Neutral, (1) Ground	AMPS	444	361	278	222	180	139	111	83
	Conductor Size Number per Phase	AWG/MCM (each)	400 (2)	400 (2)	400 (2)	300 (1)	300 (1)	300 (1)	300 (1)	300 (1)
B	AC Input to UPS Bypass (3) Phases, (1) Ground	AMPS	444	361	278	222	180	139	111	83
	Conductor Size Number per Phase	AWG/MCM (each)	400 (2)	400 (2)	400 (2)	300 (1)	300 (1)	300 (1)	300 (1)	300 (1)
C	AC Output to Critical Load (3) Phases, (1) Neutral, (1) Ground	AMPS	444	361	278	222	180	139	111	83
	Conductor Size Number per Phase	AWG/MCM (each)	400 (2)	400 (2)	400 (2)	300 (1)	300 (1)	300 (1)	300 (1)	300 (1)
D	UPS/PTC Output to MBM Cabinet (MIS) (3) Phases, (1) Neutral, (1) Ground	AMPS	444	361	278	222	180	139	111	83
	Conductor Size Number per Phase	AWG/MCM (each)	400 (2)	400 (2)	400 (2)	300 (1)	300 (1)	300 (1)	300 (1)	300 (1)
E	Control Wiring to UPS (2) Conductors	VOLTS	120	120	120	120	120	120	120	120
		AMPS	1	1	1	1	1	1	1	1

Note: Callout letters **A, B, C, D,** and **E** map to drawing 164201177-6 (Reverse Transfer Connection) and 164201177-9 (Parallel Connection). Read and understand the notes on drawings when planning your installation.

DESCRIPTION: INSTALLATION NOTES	
DRAWING NO: 164201177-1	SHEET: 3 of 4
REVISION: C	DATE: 041500

**Table A-4. Rating and External Wiring Requirements for Powerware 9315
MBM 50 – 160KVA, 380:380VAC, 400:400VAC, 415:415VAC**

RATING AND EXTERNAL WIRING REQUIREMENT		UNITS	RATING 50/60 HZ							
BASIC UNIT RATING AT 0.8 LAGGING PF LOAD		KVA KW	160 128	130 104	100 80	80 64	65 52	50 40	40 32	30 24
UPS INPUT VOLTAGE BYPASS INPUT/UPS OUTPUT VOLTAGE		VOLTS VOLTS	380/400/415 380/400/415							
A	AC INPUT TO MAINTENANCE BYPASS (3) PHASES, (1) GROUND	AMPS	231	188	146	115	97	74	60	45
	CONDUCTOR SIZE NUMBER PER PHASE	AWG/MCM (each)	300 (1)	300 (1)	300 (1)	300 (1)	300 (1)	1 (1)	1 (1)	1 (1)
B	AC INPUT TO UPS BYPASS (3) PHASES, (1) GROUND	AMPS	231	188	146	115	97	74	60	45
	CONDUCTOR SIZE NUMBER PER PHASE	AWG/MCM (each)	300 (1)	300 (1)	300 (1)	300 (1)	300 (1)	1 (1)	1 (1)	1 (1)
C	AC OUTPUT TO CRITICAL LOAD (3) PHASES, (1) NEUTRAL, (1) GROUND	AMPS	231	188	146	115	97	74	60	45
	CONDUCTOR SIZE NUMBER PER PHASE	AWG/MCM (each)	300 (1)	300 (1)	300 (1)	300 (1)	300 (1)	1 (1)	1 (1)	1 (1)
D	UPS/PTC OUTPUT TO MBM CABINET (MIS) (3) PHASE, (1) NEUTRAL, (1) GROUND	AMPS	231	188	146	115	97	74	60	45
	CONDUCTOR SIZE NUMBER PER PHASE	AWG/MCM (each)	300 (1)	300 (1)	300 (1)	300 (1)	300 (1)	1 (1)	1 (1)	1 (1)
E	CONTROL WIRING TO UPS	VOLTS	120	120	120	120	120	120	120	120
	(2) CONDUCTORS	AMPS	1	1	1	1	1	1	1	1

Note: Callout letters **A, B, C, D,** and **E** map to drawing 164201177-4 (Reverse Transfer Connection) and 164201177-7 (Parallel Connection). Read and understand the notes on drawings when planning your installation.

DESCRIPTION:	INSTALLATION NOTES	
DRAWING NO:	164201177-1	SHEET: 4 of 4
REVISION: C	DATE: 041500	

**Table B. Circuit Breaker Requirements for Powerware 9315
 MBM 30–160KVA, 380:380VAC, 400:400VAC, 415:415VAC, 600:600VAC,
 480:208VAC, 600:208VAC, 208:208VAC, 480:480VAC.**

MBM FAMILY	MBM Model No.	V _{in} /V _{out}	I _{in} /I _{out}	BIB1 & BIB2		MBP & MIS	
				Frame/Trip	Instantaneous Trip Range	Frame/Trip	Instantaneous Trip Range
30KVA	MBM 50/30–48/20	480V/208V	36A/83A	100A/40A	150–1200A	250A/100A	375–3000A
	MBM 50/30–48/48	480V/480V	36A/36A	100A/40A	150–1200A	100A/40A	150–1200A
	MBM 50/30–60/20	600V/208V	29A/83A	100A/40A	150–1200A	250A/100A	375–3000A
	MBM 50/30–20/20	208V/208V	83A/83A	250A/100A	375–3000A	250A/100A	375–3000A
	MBM 50/30–38/38	380V/380V	45A/45A	100A/50A	150–1200A	100A/50A	150–1200A
	MBM 50/30–40/40	400V/400V	45A/45A	100A/50A	150–1200A	100A/50A	150–1200A
	MBM 50/30–41/41	410V/410V	45A/45A	100A/50A	150–1200A	100A/50A	150–1200A
40KVA	MBM 50/40–48/20	480V/208V	48A/111A	100A/50A	150–1200A	250A/125A	375–3000A
	MBM 50/40–48/48	480V/480V	48A/48A	100A/50A	150–1200A	100A/50A	150–1200A
	MBM 50/40–60/20	600V/208V	38A/111A	100A/40A	150–1200A	250A/125A	375–3000A
	MBM 50/40–20/20	208V/208V	111A/111A	250A/125A	375–3000A	250A/125A	375–3000A
	MBM 50/40–38/38	380V/380V	60A/60A	100A/70A	150–1200A	100A/70A	150–1200A
	MBM 50/40–40/40	400V/400V	60A/60A	100A/70A	150–1200A	100A/70A	150–1200A
	MBM 50/40–41/41	415V/415V	60A/60A	100A/70A	150–1200A	100A/70A	150–1200A
50KVA	MBM 50/50–48/20	480V/208V	60A/139A	100A/70A	150–1200A	250A/150A	375–3000A
	MBM 50/50–48/48	480V/480V	60A/60A	100A/70A	150–1200A	100A/70A	150–1200A
	MBM 50/50–60/20	600V/208V	48A/139A	100A/50A	150–1200A	250A/150A	375–3000A
	MBM 50/50–20/20	208V/208V	139A/139A	250A/150A	375–3000A	250A/150A	375–3000A
50KVA	MBM 80/50–48/20	480V/208V	60A/139A	100A/70A	150–1200A	250A/150A	375–3000A
	MBM 80/50–48/48	480V/480V	60A/60A	100A/70A	150–1200A	100A/70A	150–1200A
	MBM 80/50–60/20	600V/208V	48A/139A	100A/50A	150–1200A	250A/150A	375–3000A
	MBM 80/50–38/38	380V/380V	74A/74A	100A/80A	150–1200A	100A/80A	150–1200A
	MBM 80/50–40/40	400V/400V	74A/74A	100A/80A	150–1200A	100A/80A	150–1200A
	MBM 80/50–41/41	415V/415V	74A/74A	100A/80A	150–1200A	100A/80A	150–1200A
	MBM 80/50–20/20	208V/208V	139A/139A	250A/150A	375–3000A	250A/150A	375–3000A
65KVA	MBM 80/65–48/20	480V/208V	78A/180A	100A/80A	150–1200A	250A/200A	375–3000A
	MBM 80/65–48/48	480V/480V	78A/78A	100A/80A	150–1200A	100A/80A	150–1200A
	MBM 80/65–60/20	600V/208V	63A/180A	100A/70A	150–1200A	250A/200A	375–3000A
	MBM 80/65–38/38	380V/380V	97A/97A	250A/100A	375–3000A	250A/100A	375–3000A
	MBM 80/65–40/40	400V/400V	97A/97A	250A/100A	375–3000A	250A/100A	375–3000A
	MBM 80/65–41/41	415V/415V	94A/94A	250A/100A	375–3000A	250A/100A	375–3000A
	MBM 80/65–20/20	208V/208V	180A/180A	250A/200A	375–3000A	250A/200A	375–3000A

NOTE: See Sheet 2 For Model Number Legend.

DESCRIPTION:	INSTALLATION NOTES	
DRAWING NO:	164201177–1	SHEET: 1 of 2
REVISION:	C	DATE: 041500

**Table B. Circuit Breaker Requirements for Powerware 9315
MBM 30–160KVA, 380:380VAC, 400:400VAC, 415:415VAC, 600:600VAC,
480:208VAC, 600:208VAC, 208:208VAC, 480:480VAC.**

MBM FAMILY	MBM Model No.	V _{in} /V _{out}	I _n /I _{out}	BIB1 & BIB2		MBP & MIS	
				Frame/Trip	Instantaneous Trip Range	Frame/Trip	Instantaneous Trip Range
MBM 80	MBM 80/50–48/20	480V/208V	60A/139A	100A/70A	150–1200A	250A/150A	375–3000A
80KVA	MBM 80/80–48/20	480V/208V	96A/222A	100A/100A	150–1200A	250A/237A	375–3000A
	MBM 80/80–48/48	480V/480V	96A/96A	100A/100A	150–1200A	100A/100A	150–1200A
	MBM 80/80–60/20	600V/208V	77A/222A	100A/80A	150–1200A	250A/237A	375–3000A
	MBM 80/80–38/38	380V/380V	115A/115A	250A/125A	375–3000A	250A/125A	375–3000A
	MBM 80/80–40/40	400V/400V	115A/115A	250A/125A	375–3000A	250A/125A	375–3000A
	MBM 80/80–41/41	415V/415V	115A/115A	250A/125A	375–3000A	250A/125A	375–3000A
MBM 160	MBM 80/80–20/20	208V/208V	222A/222A	250A/237A	375–3000A	250A/237A	375–3000A
100KVA	MBM 160/100–48/20	480V/208V	120A/278A	250A/125A	375–3000A	600A/300A	900–7200A
	MBM 160/100–48/48	480V/480V	120A/120A	250A/125A	375–3000A	250A/125A	375–3000A
	MBM 160/100–60/20	600V/208V	96A/278A	250A/100A	375–3000A	600A/300A	900–7200A
	MBM 160/100–60/60	600V/600V	96A/96A	250A/100A	375–3000A	250A/100A	375–3000A
	MBM 160/100–38/38	380V/380V	146A/146A	250A/150A	375–3000A	250A/150A	375–3000A
	MBM 160/100–40/40	400V/400A	146A/146A	250A/150A	375–3000A	250A/150A	375–3000A
	MBM 160/100–41/41	415V/415V	146A/146A	250A/150A	375–3000A	250A/150A	375–3000A
	MBM 160/100–20/20	208V/208A	278A/278A	600A/300A	900–7200A	600A/300A	900–7200A
130KVA	MBM 160/130–48/20	480V/208V	156A/361A	250A/175A	375–3000A	600A/420A	900–7200A
	MBM 160/130–48/48	480V/480V	156A/156A	250A/175A	375–3000A	250A/175A	375–3000A
	MBM 160/130–60/20	600V/208V	125A/361A	250A/150A	375–3000A	600A/420A	900–7200A
	MBM 160/130–60/60	600V/600V	125A/125A	250A/150A	375–3000A	250A/150A	375–3000A
	MBM 160/130–38/38	380V/380V	188A/188A	250A/200A	375–3000A	250A/200A	375–3000A
	MBM 160/130–40/40	400V/400V	188A/188A	250A/200A	375–3000A	250A/200A	375–3000A
	MBM 160/130–41/41	415V/415V	188A/188A	250A/200A	375–3000A	250A/200A	375–3000A
	MBM 160/130–20/20	208V/208V	361A/361A	600A/420A	900–7200A	600A/420A	900–7200A
160KVA	MBM 160/160–48/20	480V/208V	192A/444A	250A/200A	375–3000A	600A/480A	900–7200A
	MBM 160/160–48/48	480V/480V	192A/192A	250A/200A	375–3000A	250A/200A	375–3000A
	MBM 160/160–60/20	600V/208V	153A/444A	250A/175A	375–3000A	600A/480A	900–7200A
	MBM 160/160–60/60	600V/600V	153A/153A	250A/175A	375–3000A	250A/175A	375–3000A
	MBM 160/160–38/38	380V/380V	231A/231A	250A/237A	375–3000A	250A/237A	375–3000A
	MBM 160/160–40/40	400V/400V	231A/231A	250A/237A	375–3000A	250A/237A	375–3000A
	MBM 160/160–41/41	415V/415V	231A/231A	250A/237A	375–3000A	250A/237A	375–3000A
	MBM 160/160–20/20	208V/208V	444A/444A	600A/480A		600A/480A	900–7200A

NOTE: Model Number Legend

1. MBM 50/30–20/20 means MBM cabinet, Family 50, 208V (input) and 208V (output), model 30 (30kVA).
2. All breakers are 100% UL rated with Interrupting Capacity (IC) of 65kAIC@480VAC.

DESCRIPTION:	INSTALLATION NOTES	
DRAWING NO:	164201177–1	SHEET: 2 of 2
REVISION:	C	DATE: 041500

Table C-1. Power Cable Terminations

Terminal Function	Terminal	Function	With Optional BIB			Without Optional BIB			Powerware 9315 UPS Model in KVA (see note below)
			Size of Pressure Terminal	Tightening Torque N-M (lb-in)	Int. Hex Size (In.)	Size of Pressure Terminal	Tightening Torque N-M (lb-in)	Int. Hex Size (In.)	
AC Input to MBM	E1, E2, E3	Phase A, Phase B, Phase C	2-#6-350 kcmil (Note 2)	31.1 (275)	3/8	1-#6-350 kcmil (Note 3)	31.1 (275)	3/8	30-160KVA, 38/38, 48/48, 60/60 30-80KVA, 20/20
			2-#6-350 kcmil (Note 2)	31.1 (275)	3/8	2-#6-350 kcmil (Note 2)	31.1 (275)	3/8	30-160KVA, 48/20, 60/20
			4-#2-600 kcmil (Note 2)	56.5 (500)	1/2	3-#3/0-400 kcmil (Note 3)	42.4 (375)	5/16	100-160KVA, 20/20
AC Input to UPS Bypass (BIB breaker Load side)	BIB-2, BIB-4, BIB-6	Phase A, Phase B, Phase C	1-#6-350 kcmil	31.1 (275)	3/8	N/A	N/A	N/A	30-160KVA, 38/38, 48/48, 60/60, 48/20, 60/20 30-80KVA, 20/20
			3-#3/0-400 kcmil	42.4 (375)	5/16	N/A	N/A	N/A	100-160KVA, 20/20
UPS Output to MBM (MIS breaker Line side)	MIS-1, MIS-3, MIS-5	Phase A, Phase B, Phase C	1-#6-350 kcmil	311 (275)	3/8	1-#6-350 kcmil	311 (275)	3/8	30-160KVA, 38/38, 48/48, 60/60 30-80KVA, 48/20, 60/20, 20/20
			3-#3/0-400 kcmil	42.4 (375)	5/16	3-#3/0-400 kcmil	42.4 (375)	5/16	100-160KVA, 48/20, 60/20, 20/20
MBM Output to Critical Load	E13, E14, E15	Phase A, Phase B, Phase C	2-#6-350 kcmil	31.1 (275)	3/8	2-#6-350 kcmil	31.1 (275)	3/8	30-160KVA, 38/38, 48/48, 60/60 30-80KVA, 48/20, 60/20, 20/20
			4-#2-600 kcmil	56.5 (500)	1/2	4-#2-600 kcmil	56.5 (500)	1/2	100-160KVA, 48/20, 60/20, 20/20
Neutral Lug	E12	Neutral	12-#2-500 kcmil	56.5 (500)	1/2	12-#2-500 kcmil	56.5 (500)	1/2	30-160KVA, all voltages
Customer Ground Lug	Ground	Ground	2-#6-350 kcmil	31.1 (275)	3/8	2-#6-350 kcmil	31.1 (275)	3/8	30-160KVA, all voltages

NOTES: Model Number Legend

- 38/38: 380VAC in-380VAC out; 48/48: 480VAC in-480VAC out; 60/60: 600VAC in-600VAC out
48/20: 480VAC in-208VAC out; 60/20: 600VAC in-208VAC out; 20/20: 208VAC in-208VAC out
- AC input wiring is connected to input lugs E1-E3. Lugs are located on the right side of BIB breaker.
- AC input wiring is connected directly to the line side of MBP breaker (MBP-1, MBP-3, and MBP-5).
- AC input wiring is connected to input lugs E1-E3.

DESCRIPTION:	INSTALLATION NOTES	
DRAWING NO:	164201177-1	SHEET: 1 of 2
REVISION:	C	DATE: 041500

Table C-2. Control Wiring Requirements and Termination Requirement for Reverse Transfer (RT) System.						
Connecting Point in MBM Cabinet	Size of Pressure Termination (lb-in)	Connection Point in UPS	Size of Pressure Termination (lb-in)	Recommended Wire Size	Maximum Voltage and Current	Remarks
TB1-12	#18-#8 (55)	TB6-1	#18-#8 (55)	#18-#14	120VAC 1.0A	See Fig 1. (Twisted Pair)
TB1-14		TB6-2				

Table C-3. Control Wiring Requirements and Termination Requirement for Parallel Redundant System.						
Connecting Point in MBM Cabinet	Size of Pressure Termination (lb-in)	Connection Point in UPS	Size of Pressure Termination (lb-in)	Recommended Wire Size	Maximum Voltage and Current	Remarks
TB1-12	#18-#8 (55)	TB6-1 (UPS1)	#18-#8 (55)	#18-#14	120VAC 1.0A	See Fig 2. (Twisted Pair)
TB1-13		TB6-1 (UPS2)				
TB1-13		TB6-2 (UPS1)				
TB1-14		TB6-2 (UPS2)				

NOTES FOR TABLES C-2 AND C-3:

- Install the copper wiring in a conduit separate from the power wiring.
- Control wiring is NEC Class 1.
- Control wiring from each UPS Module should be twisted.

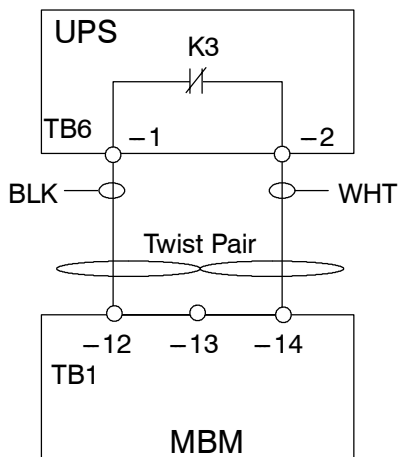

Figure 1. (Reverse Transfer)

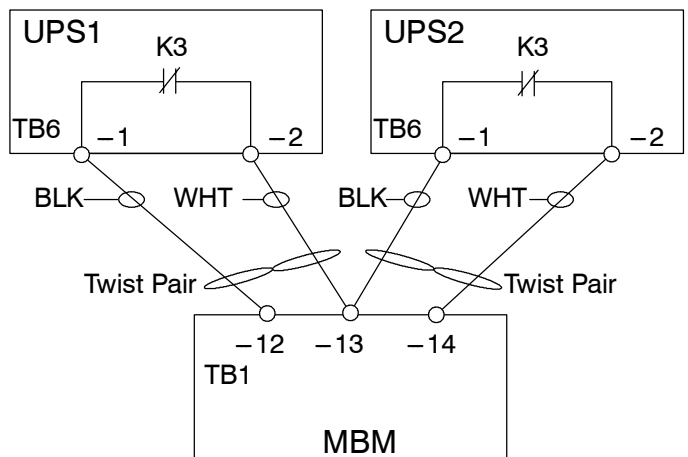
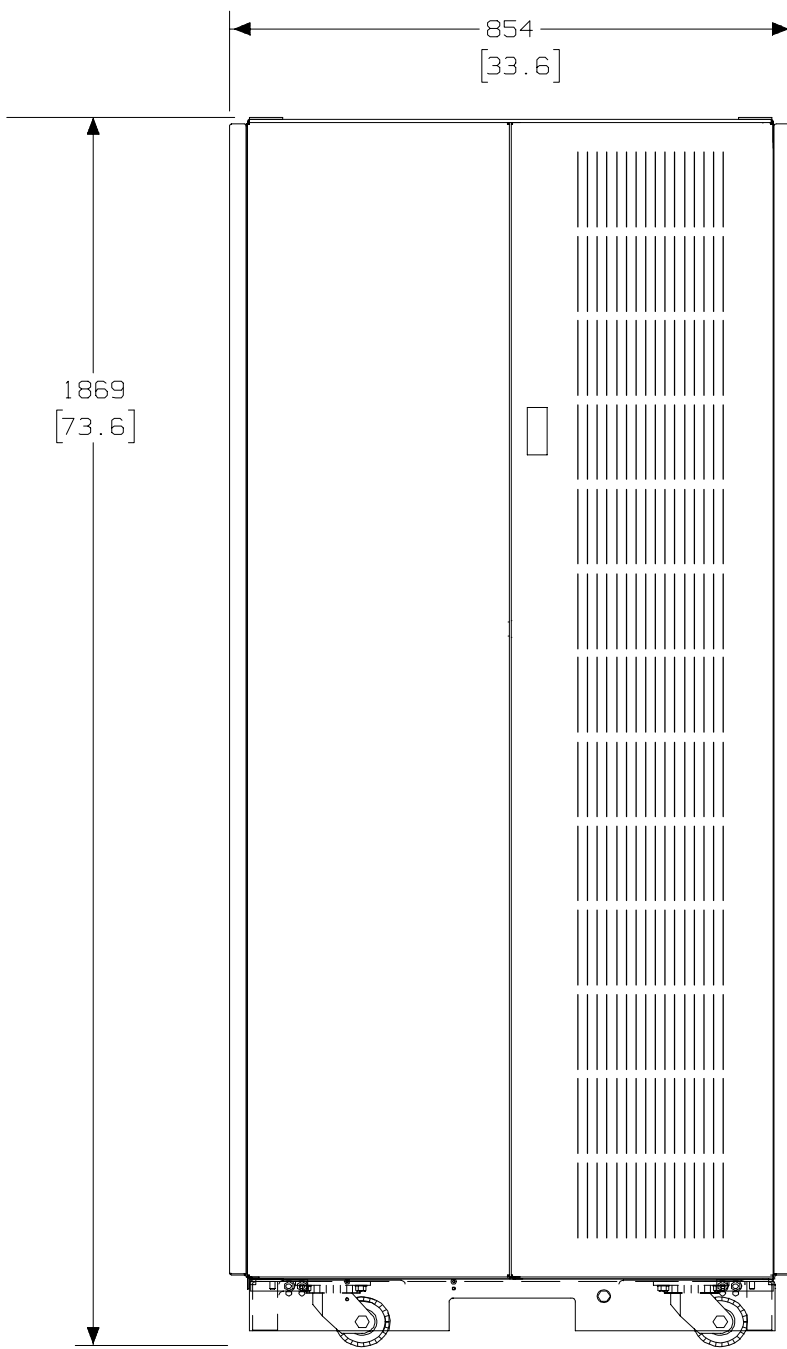

Figure 2. (Parallel Redundant)

DESCRIPTION: INSTALLATION NOTES		
DRAWING NO:	164201177-1	SHEET: 2 of 2
REVISION:	C	DATE: 041500



Dimensions are in millimeters (inches)

DESCRIPTION: TYPICAL MBM CABINET – 30-160kVA with or without XFMR		
DRAWING NO:	164201177-2	SHEET: 1 of 3
REVISION:	A	DATE: 080498

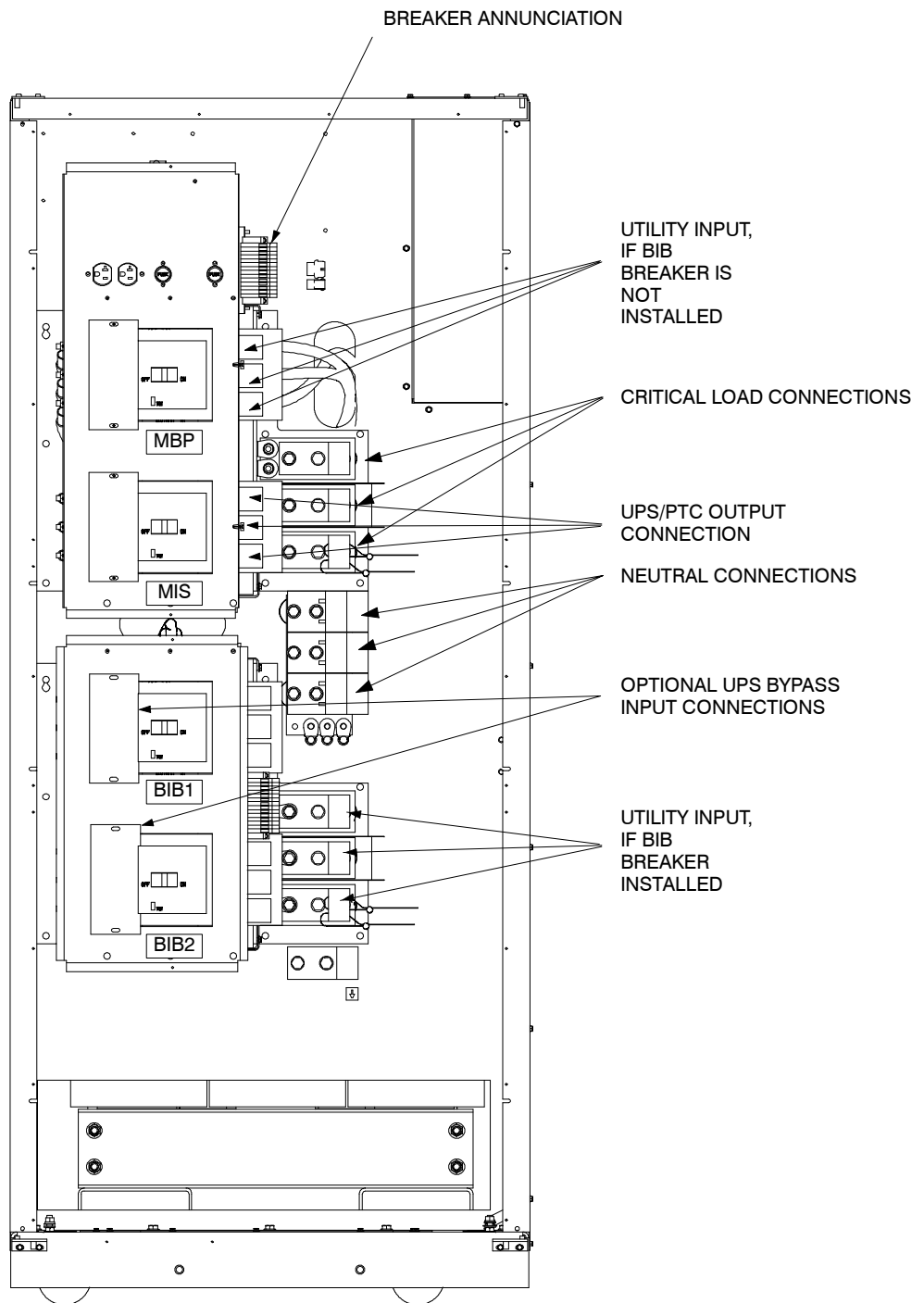

DESCRIPTION: TYPICAL MBM CABINET – 30-160kVA with or without XFMR INTERIOR COMPONENTS		
DRAWING NO:	164201177-2	SHEET: 2 of 3
REVISION:	A	DATE: 080498

TOP VIEW

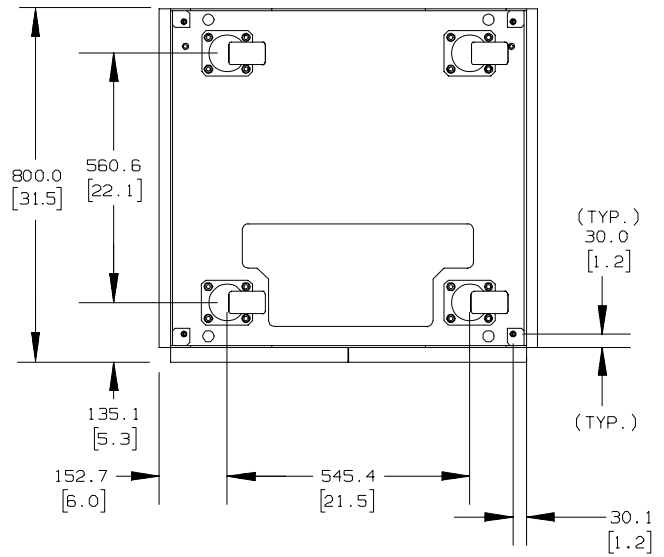
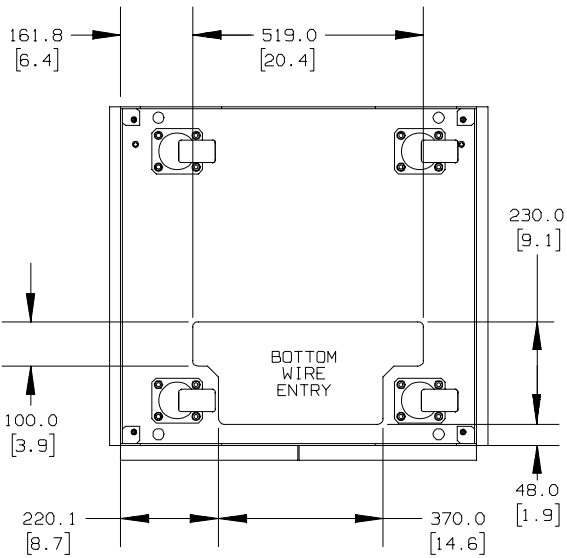
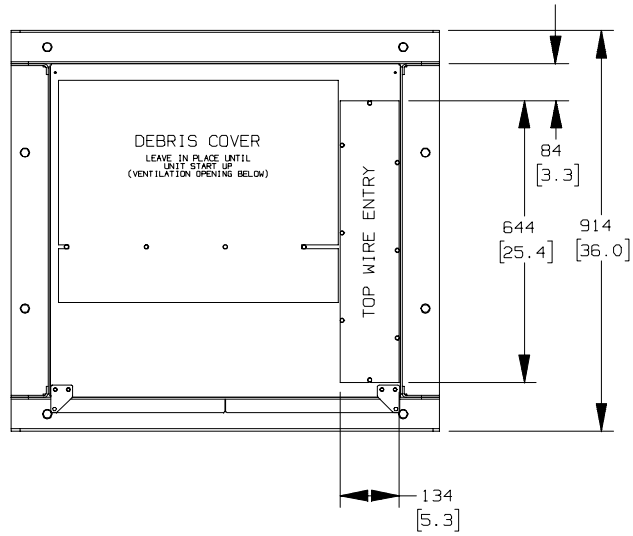

BOTTOM VIEW

DESCRIPTION: TYPICAL MBM CABINET – 30-160kVA with or without XFMR TOP and BOTTOM VIEW		
DRAWING NO:	164201177-2	SHEET: 3 of 3
REVISION:	A	DATE: 080498

Dimensions are in millimeters (inches)

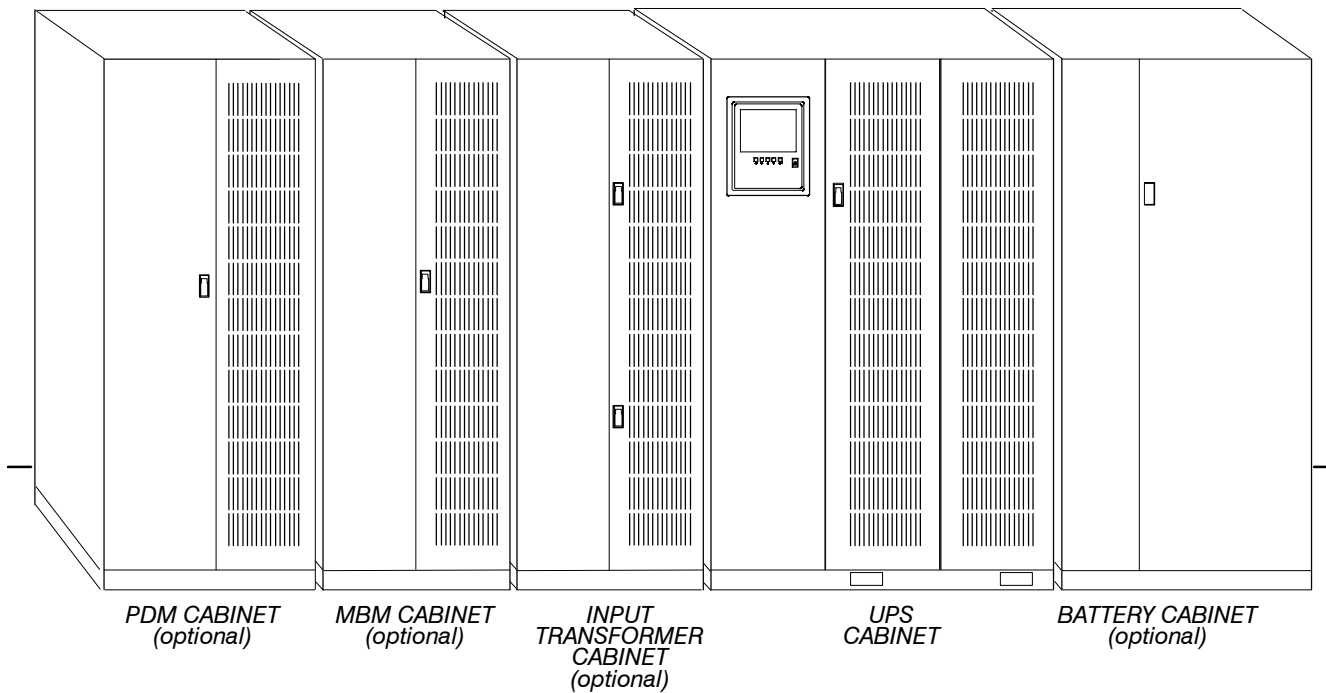

30 – 160kVA UPS System with MBM

<i>DESCRIPTION:</i>	TYPICAL UPS SYSTEM WITH MBM	
<i>DRAWING NO:</i>	164201177 – 3	<i>SHEET:</i> 1 of 1
<i>REVISION:</i>	A	<i>DATE:</i> 080498

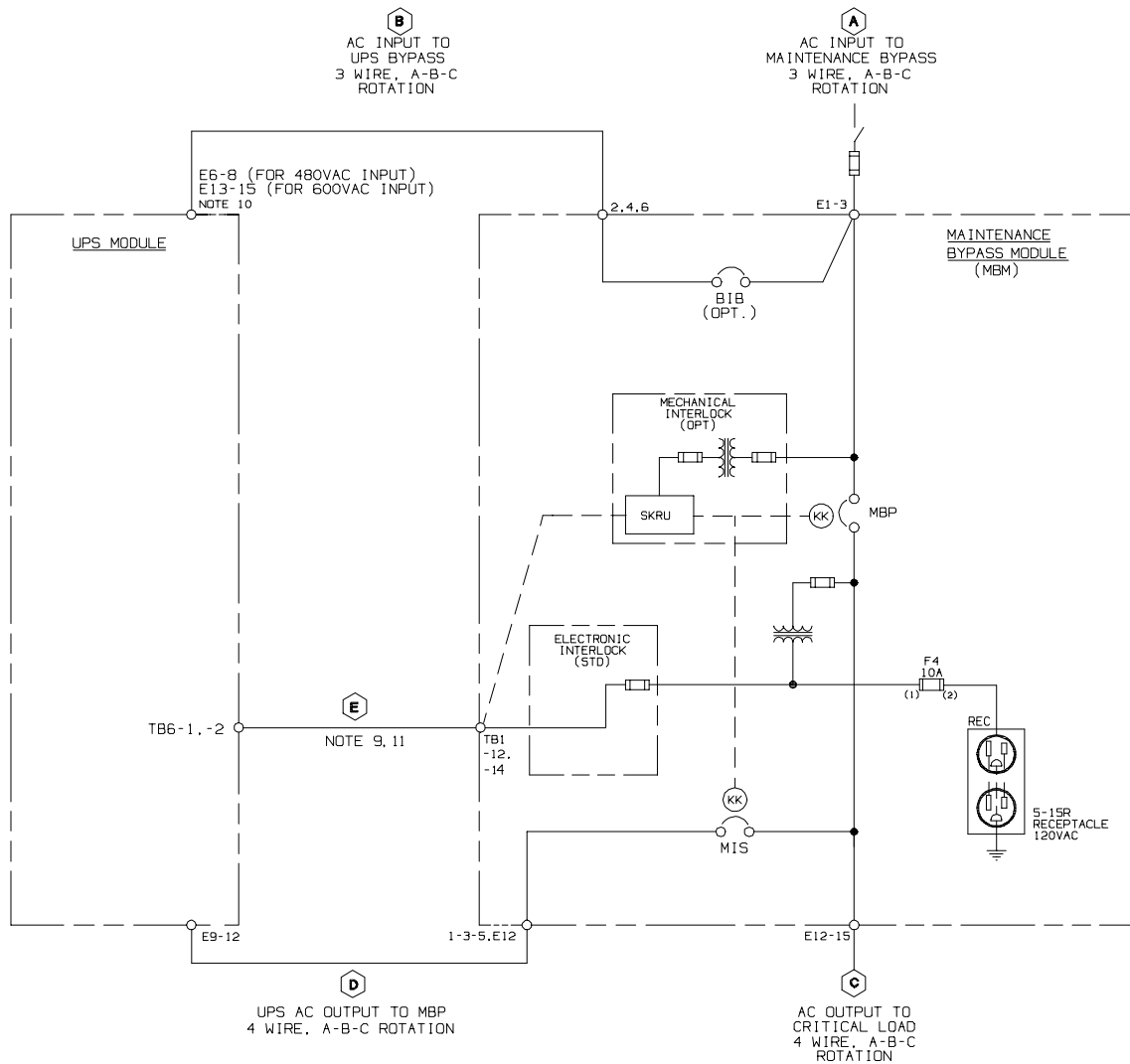

Read and understand the following notes while planning your installation:

1. Refer to national and local electric codes for acceptable external wiring practices.
2. Material and labor for external wiring requirements are to be provided by others.
3. For external wiring requirement, including the minimum AWG size of external wiring, see the appropriate column in Table A-2 and A-4. The power wiring for this equipment is rated at 90 degrees Celsius.
4. The output of the UPS is not a separately derived source. Output neutral is not bonded to equipment ground through the main bonding jumper. Refer to NEC and local codes for proper grounding practices.
5. The maintenance bypass (MBM) source must contain overcurrent protection with the maximum trip setting of 125% of the full load input current in Table A-2 and A-4.
6. The Bypass three-phase feeds should be symmetrical about ground.
7. Transfer sequence instructions for the MBM are placed on the breaker access panel behind the cabinet doors.
8. Control wiring must be installed in separate conduit from the power wiring.
9. Electronic interlock is a standard part of the maintenance bypass module cabinet. This electronic interlock can be replaced with an optional (extra cost) mechanical interlock if required.
10. Refer to UPS Installation Manual for proper Bypass terminating lugs at UPS cabinet or input transformer cabinet.
11. Refer to Table C-2 for control wiring connections.
12. A Maintenance Bypass neutral feeder must be supplied when the MBM output neutral is used. If no Maintenance Bypass neutral is supplied, the MBM output neutral is not to be used. In neither case shall the MBM output neutral be bonded to ground.

LEGEND

- MIS: MAINTENANCE ISOLATION BREAKER
 MBP: MAINTENANCE BYPASS BREAKER
 BIB: BYPASS INPUT BREAKER
 SKRU: SOLENOID KEY RELEASE UNIT (MECHANICAL INTERLOCK)
 RT: REVERSE TRANSFER

DESCRIPTION: ONLINE – 30-160kVA, RT, 480:480VAC, 600:600VAC, 400:400VAC		
DRAWING NO:	164201177-4	SHEET: 1 of 1
REVISION:	A	DATE: 080498

110100057 D3

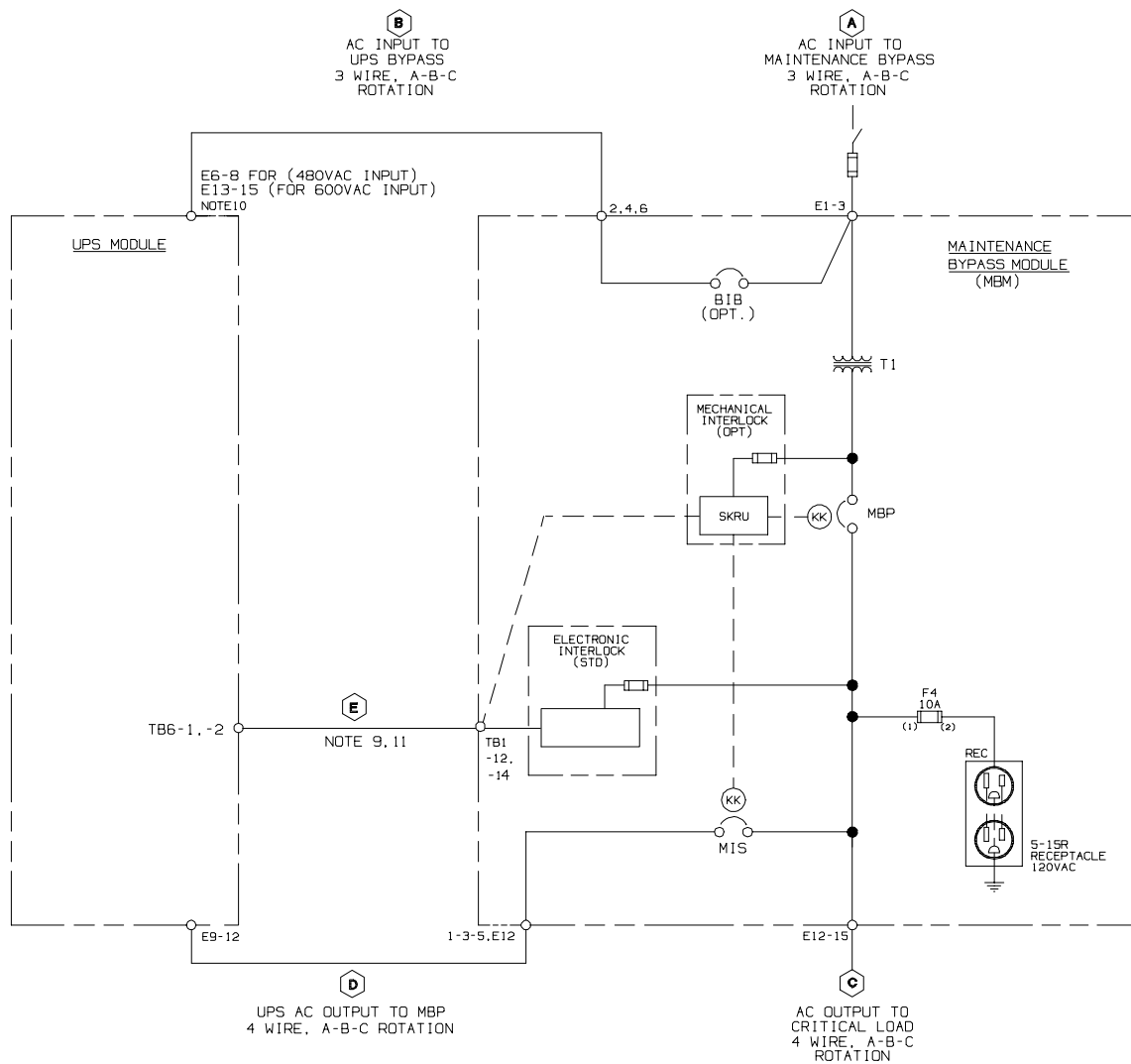

Read and understand the following notes while planning your installation:

1. Refer to national and local electric codes for acceptable external wiring practices.
2. Material and labor for external wiring requirements are to be provided by others.
3. For external wiring requirement, including the minimum AWG size of external wiring, see the appropriate column in Table A-1. The power wiring for this equipment is rated at 90 degrees Celsius.
4. The output of the UPS is a separately derived source. Output neutral is bonded to equipment ground through the main bonding jumper. Refer to NEC and local codes for proper grounding practices.
5. The maintenance bypass (MBM) source must contain overcurrent protection with the maximum trip setting of 125% of the full load input current in Table A-1.
6. The Bypass three-phase feeds should be symmetrical about ground.
7. Transfer sequence instructions for the MBM are placed on the breaker access panel behind the cabinet doors.
8. Control wiring must be installed in separate conduit from the power wiring.
9. Electronic interlock is a standard part of the maintenance bypass module cabinet. This electronic interlock can be replaced with an optional (extra cost) mechanical interlock if required.
10. Refer to UPS Installation Manual for proper Bypass terminating lugs.
11. Refer to Table C-2 for control wiring connections.

LEGEND

MIS: MAINTENANCE ISOLATION BREAKER
 MBP: MAINTENANCE BYPASS BREAKER
 BIB: BYPASS INPUT BREAKER
 SKRU: SOLENOID KEY RELEASE UNIT (MECHANICAL INTERLOCK)
 RT: REVERSE TRANSFER

DESCRIPTION:	ONELINE – 30-160kVA, RT, 480:208VAC, 600:208VAC	
DRAWING NO:	164201177-5	SHEET: 1 of 1
REVISION:	A	DATE: 080498

110100056 D1

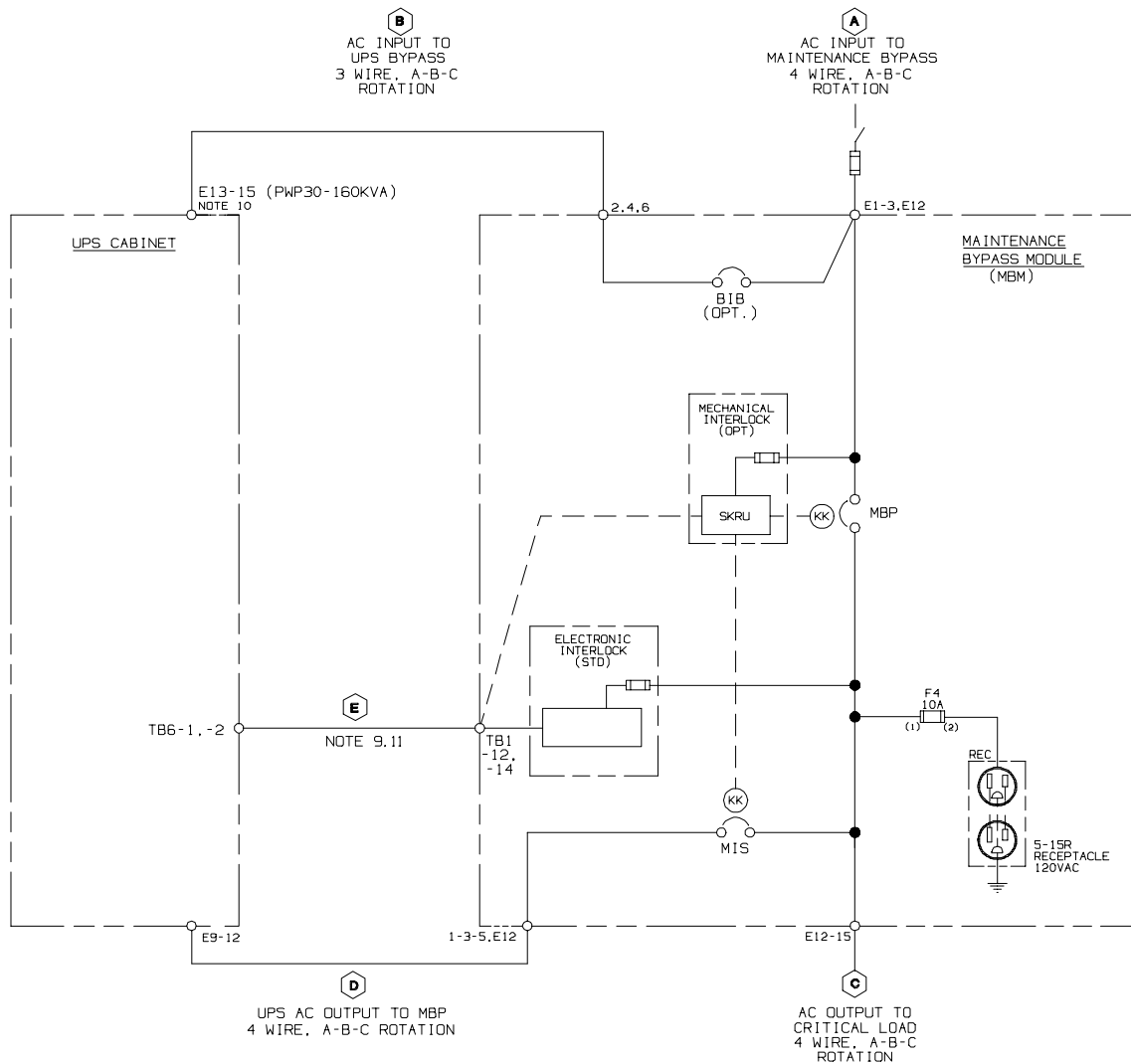

Read and understand the following notes while planning your installation:

1. Refer to national and local electric codes for acceptable external wiring practices.
2. Material and labor for external wiring requirements are to be provided by others.
3. For external wiring requirement, including the minimum AWG size of external wiring, see the appropriate column in Table A-3. The power wiring for this equipment is rated at 90 degrees Celsius.
4. The output of the UPS is not a separately derived source. Output neutral is not bonded to equipment ground through the main bonding jumper. Refer to NEC and local codes for proper grounding practices.
5. The maintenance bypass (MBM) source must contain overcurrent protection with the maximum trip setting of 125% of the full load input current in Table A-3.
6. The Bypass three-phase feeds should be symmetrical about ground.
7. Transfer sequence instructions for the MBM are placed on the breaker access panel behind the cabinet doors.
8. Control wiring must be installed in separate conduit from the power wiring.
9. Electronic interlock is a standard part of the maintenance bypass module cabinet. This electronic interlock can be replaced with an optional (extra cost) mechanical interlock if required.
10. Refer to UPS Installation Manual for proper bypass terminating lugs at UPS cabinet or at input transformer cabinet.
11. Refer to Table C-2 for control wiring connections.

LEGEND

- MIS: MAINTENANCE ISOLATION BREAKER
 MBM: MAINTENANCE BYPASS BREAKER
 BIB: BYPASS INPUT BREAKER
 SKRU: SOLENOID KEY RELEASE UNIT (MECHANICAL INTERLOCK)
 RT: REVERSE TRANSFER

DESCRIPTION: ONELINE – 30-160kVA, RT, 208:208VAC		
DRAWING NO:	164201177-6	SHEET: 1 of 1
REVISION:	A	DATE: 080498

110100058 D2

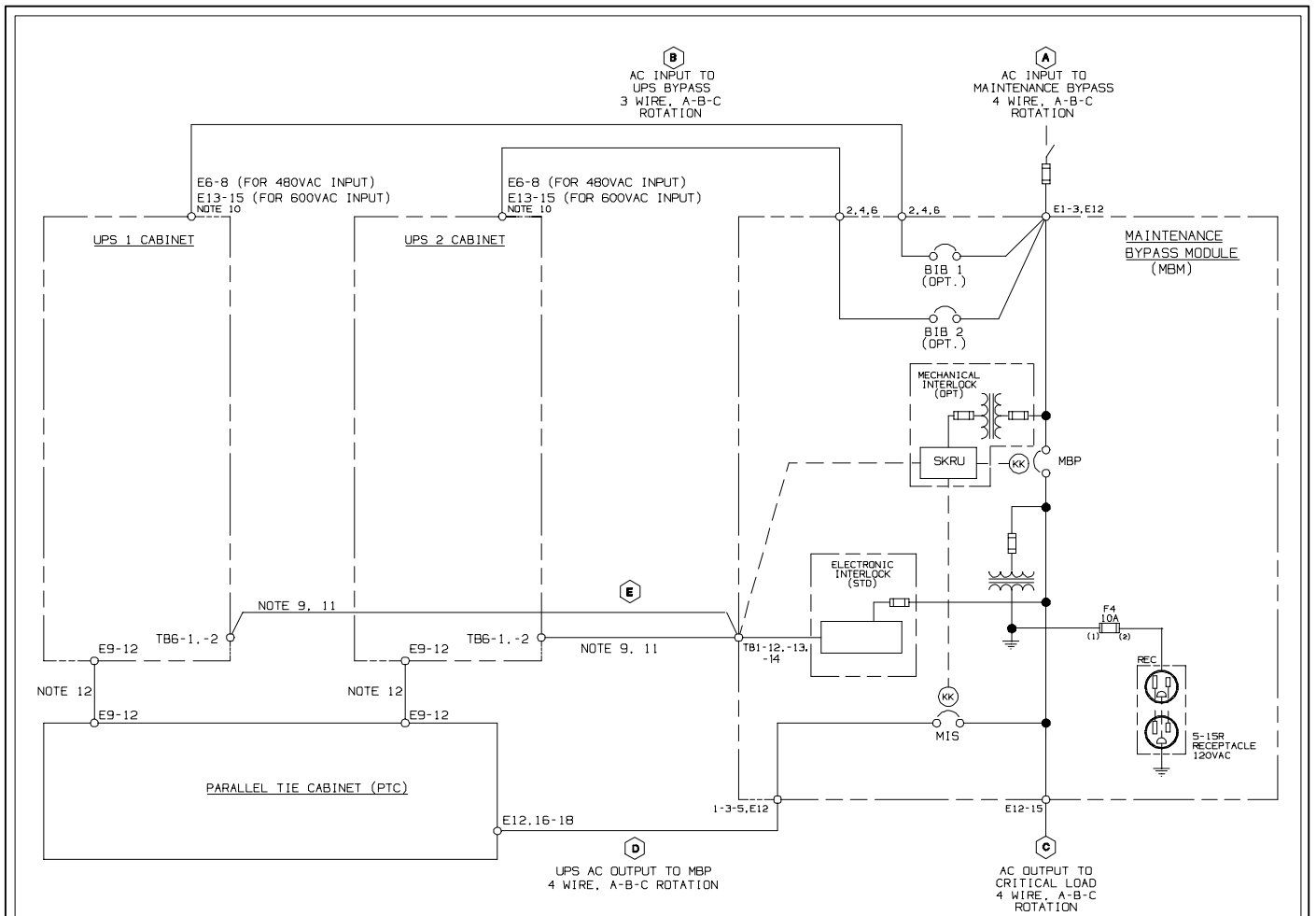

Read and understand the following notes while planning your installation:

1. Refer to national and local electric codes for acceptable external wiring practices.
2. Material and labor for external wiring requirements are to be provided by others.
3. For external wiring requirement, including the minimum AWG size of external wiring, see the appropriate column in Table A-2 and A-4. The power wiring for this equipment is rated at 90 degrees Celsius.
4. The output of the UPS is not a separately derived source. Output neutral is not bonded to equipment ground through the main bonding jumper. Refer to NEC and local codes for proper grounding practices.
5. The maintenance bypass (MBM) source must contain overcurrent protection with the maximum trip setting of 125% of the full load input current in Table A-2 and A-4.
6. The Bypass three-phase feeds should be symmetrical about ground.
7. Transfer sequence instructions for the MBM are placed on the breaker access panel behind the cabinet doors.
8. Control wiring must be installed in separate conduit from the power wiring.
9. Electronic interlock is a standard part of the maintenance bypass module cabinet. This electronic interlock can be replaced with an optional (extra cost) mechanical interlock if required.
10. Refer to UPS Installation Manual for proper Bypass terminating lugs at UPS cabinet or input transformer cabinet.
11. Refer to Table C-3 for control wiring connections.
12. Refer to Parallel Redundant System Manual for details.
13. A Maintenance Bypass neutral feeder must be supplied when the MBM output neutral is used. If no Maintenance Bypass neutral is supplied, the MBM output neutral is not to be used. In neither case shall the MBM output neutral be bonded to ground.

LEGEND

- MIS: MAINTENANCE ISOLATION BREAKER
 MBM: MAINTENANCE BYPASS BREAKER
 BIB: BYPASS INPUT BREAKER
 SKRU: SOLENOID KEY RELEASE UNIT (MECHANICAL INTERLOCK)
 PTC: PARALLEL TIE CABINET
 RT: REVERSE TRANSFER

DESCRIPTION: ONLINE – 30-160kVA, PARALLEL, 480:480VAC 600:600VAC, 400:400VAC		
DRAWING NO:	164201177-7	SHEET: 1 of 1
REVISION:	A	DATE: 080498

110100069

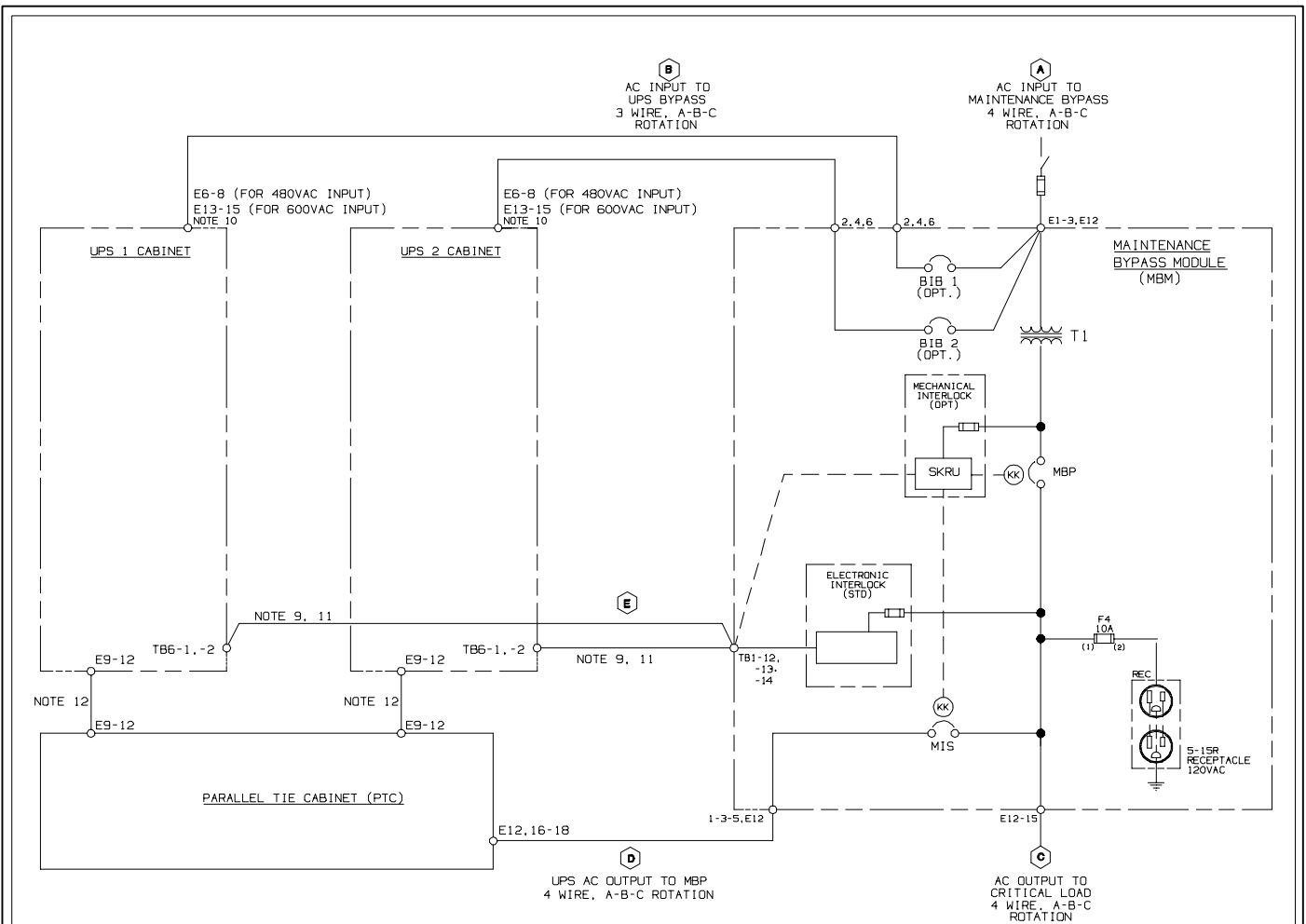

Read and understand the following notes while planning your installation:

1. Refer to national and local electric codes for acceptable external wiring practices.
2. Material and labor for external wiring requirements are to be provided by others.
3. For external wiring requirement, including the minimum AWG size of external wiring, see the appropriate column in Table A-1. The power wiring for this equipment is rated at 90 degrees Celsius.
4. The output of the UPS is a separately derived source. Output neutral is bonded to equipment ground through the main bonding jumper. Refer to NEC and local codes for proper grounding practices.
5. The maintenance bypass (MBM) source must contain overcurrent protection with the maximum trip setting of 125% of the full load input current in Table A-1.
6. The Bypass three-phase feeds should be symmetrical about ground.
7. Transfer sequence instructions for the MBM are placed on the breaker access panel behind the cabinet doors.
8. Control wiring must be installed in separate conduit from the power wiring.
9. Electronic interlock is a standard part of the maintenance bypass module cabinet. This electronic interlock can be replaced with an optional (extra cost) mechanical interlock if required.
10. Refer to UPS Installation Manual for proper Bypass terminating lugs.
11. Refer to Table C-3 for control wiring connections.
12. Refer to Parallel Redundant System Manual for details.

LEGEND

- MIS: MAINTENANCE ISOLATION BREAKER
- MBP: MAINTENANCE BYPASS BREAKER
- BIB: BYPASS INPUT BREAKER
- SKRU: SOLENOID KEY RELEASE UNIT (MECHANICAL INTERLOCK)
- PTC: PARALLEL TIE CABINET
- RT: REVERSE TRANSFER

110100068

DESCRIPTION: ONLINE – 30-160kVA, PARALLEL 480:208VAC, 600:208VAC		
DRAWING NO:	164201177-8	SHEET: 1 of 1
REVISION:	A	DATE: 080498

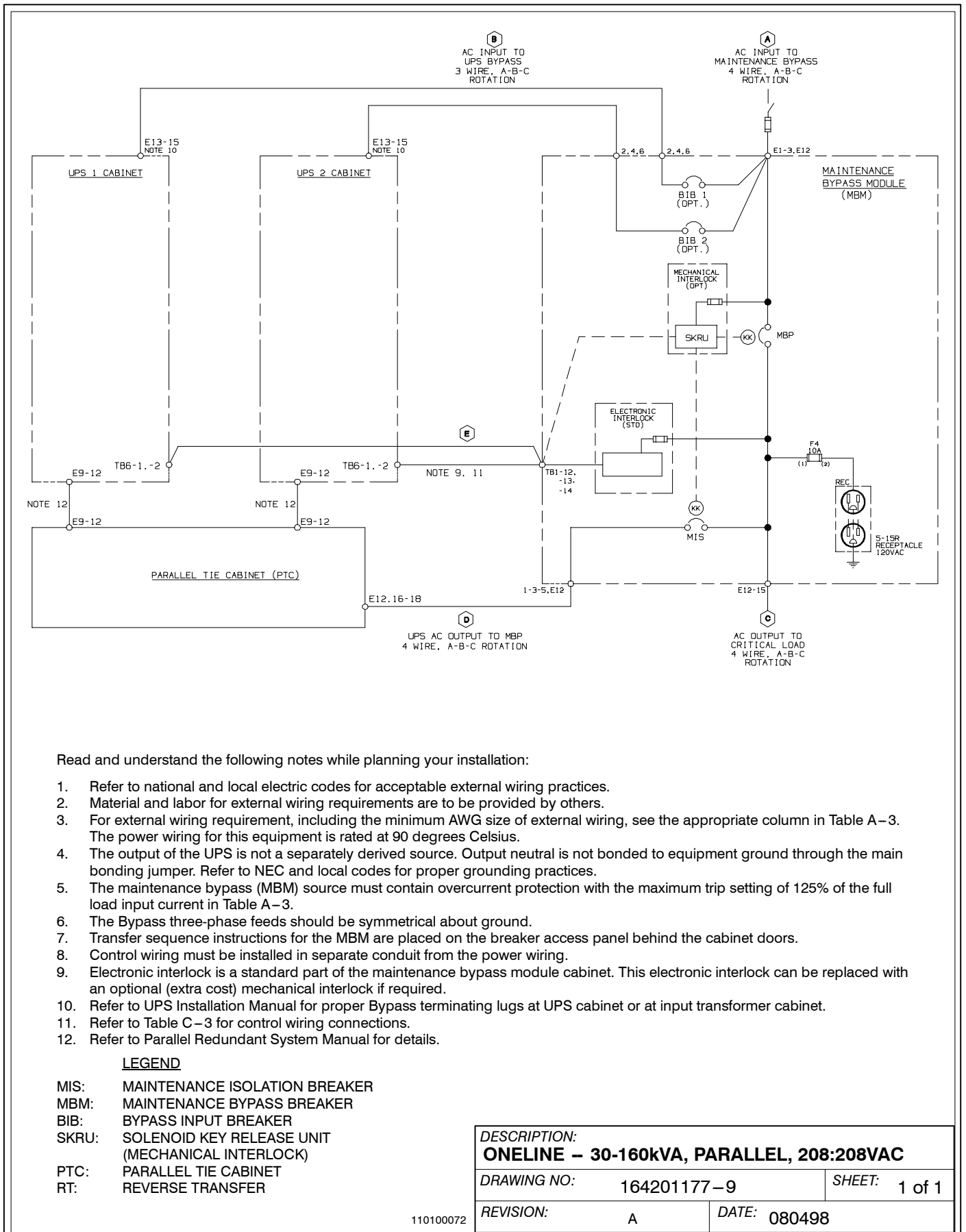

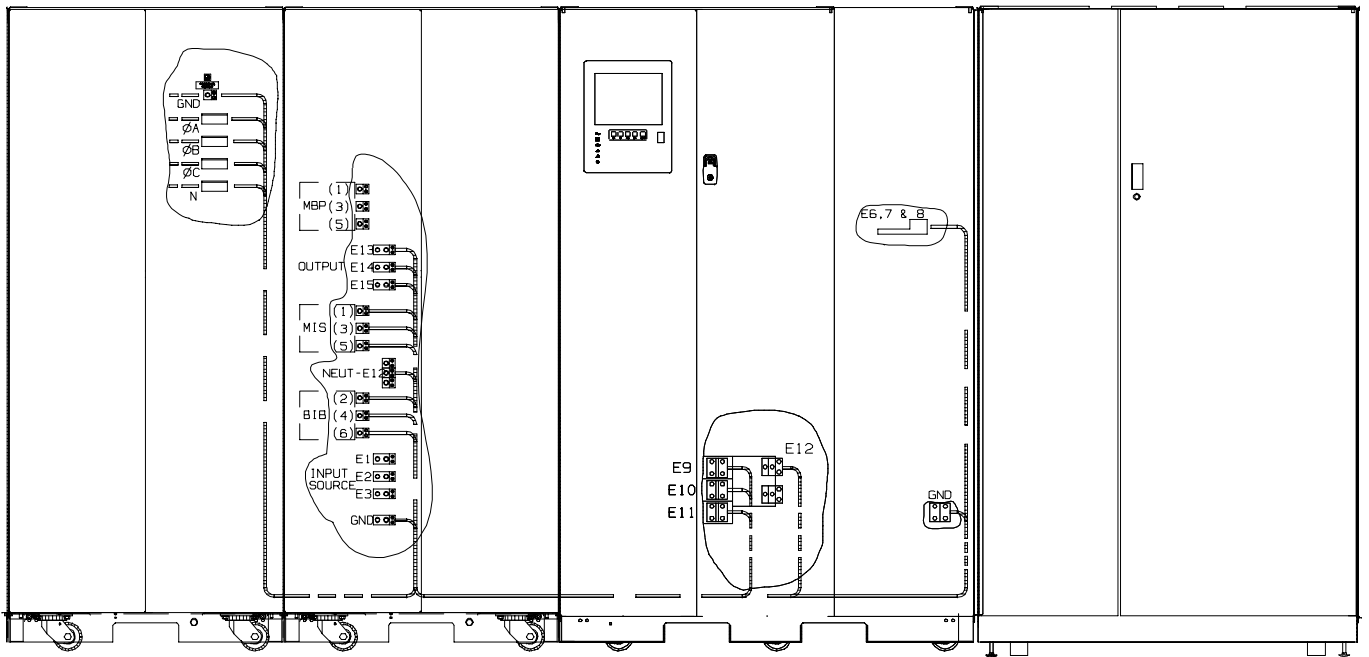

PDM CABINET
(NOTE 4)

MBM CABINET

UPS CABINET

BATTERY CABINET

LINE UP AND MATCH ARRANGEMENT #1
Applicable to POWERWARE 9315 30-160 kVA
UPS modules only. 160kVA UPS is shown.

DESCRIPTION: LINE UP AND MATCH ARRANGEMENT #1		
DRAWING NO:	164201177-10	SHEET: 1 of 4
REVISION:	A	DATE: 080498

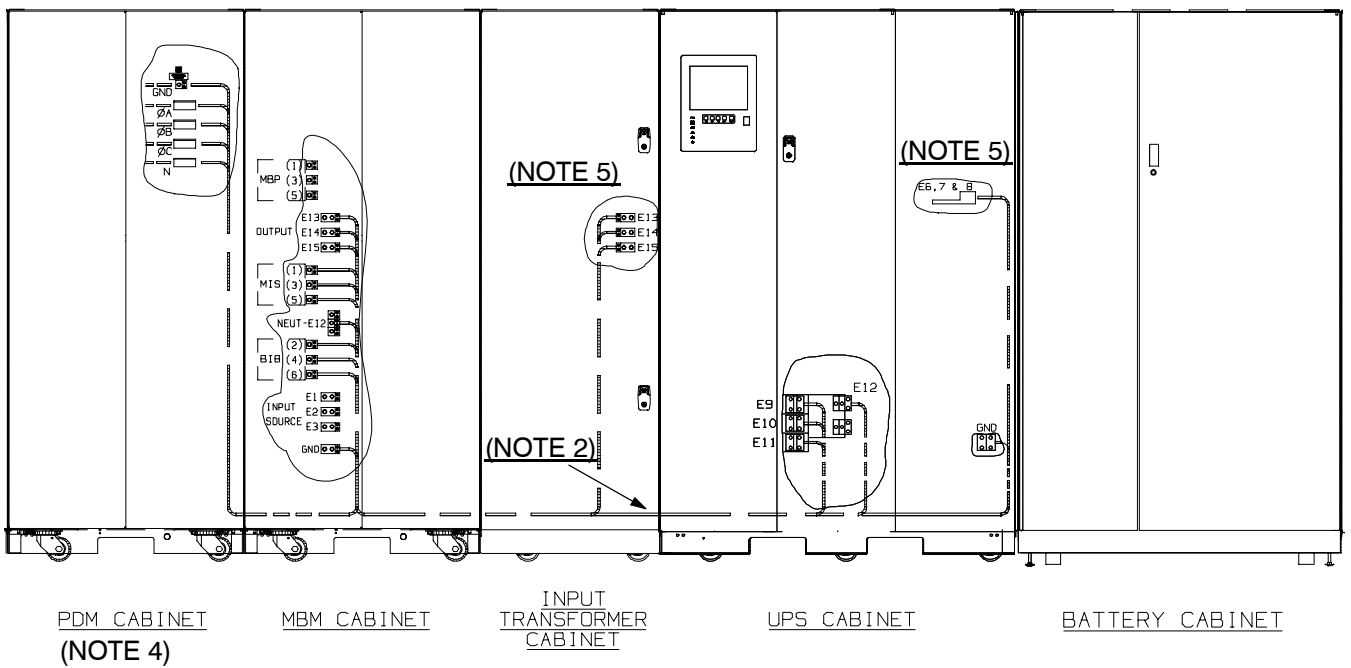

LINE UP AND MATCH ARRANGEMENT #2
Applicable to POWERWARE 9315 30–160 kVA
UPS modules only. 160kVA UPS is shown.

DESCRIPTION: LINE UP AND MATCH ARRANGEMENT #2	
DRAWING NO: 164201177-10	SHEET: 2 of 4
REVISION: A	DATE: 080498

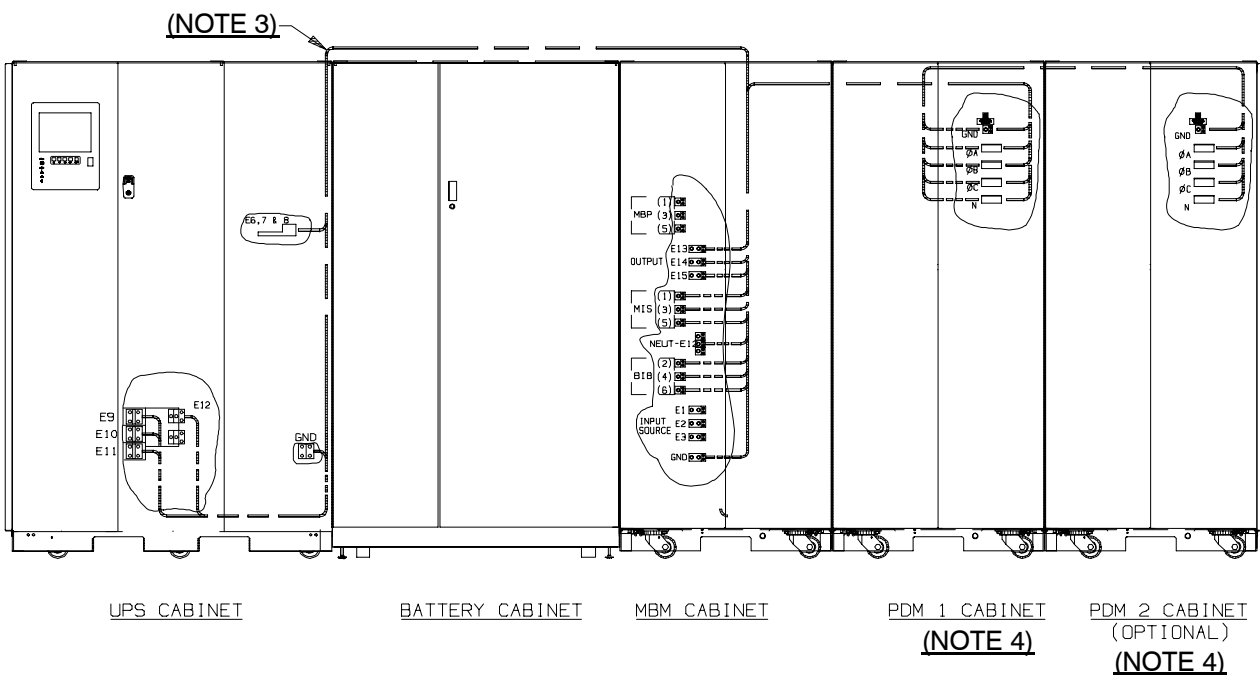

LINE UP AND MATCH ARRANGEMENT #3
Applicable to POWERWARE 9315 30–160 kVA
UPS modules only. 160kVA UPS is shown.

DESCRIPTION: LINE UP AND MATCH ARRANGEMENT #3	
DRAWING NO: 164201177-10	SHEET: 3 of 4
REVISION: A	DATE: 080498

- 1 Line up and match power and control interconnection wiring from MBM to UPS/Input Transformer cabinet is applicable for Reverse Transfer (Single UPS module) connection only and sold separately by Powerware Corporation.
- 2 Run power cables underneath the transformer.
- 3 External wiring is required and supplied by others.
- 4 The PDM cabinet is applicable IF AND ONLY IF the MBM and UPS module outputs are 3 phase, 60Hz, 280VAC.
- 5 Refer to Powerware 9315 UPS module installation manual for proper terminating lugs.

<i>DESCRIPTION:</i>	
LINE UP AND MATCH ARRANGMENT NOTES	
<i>DRAWING NO:</i>	164201177-10
<i>SHEET:</i>	4 of 4
<i>REVISION:</i>	A
<i>DATE:</i>	080498

This Page Intentionally Left Blank.