



ИБП Eaton EX 3000 3U Rack/Tower - Оборудование Eaton EX 700, 1000, 1500, 1000 RT, 1500 RT и EX

Постоянная ссылка на страницу: <https://eaton-power.ru/catalog/eaton-ex/eaton-ex-3000-3u-rack-tower/>



www.eaton.com

EX
700 - 1000
1000 RT
EXB 1000
EXB 1000

**Installation
manual**



English
Français
Deutsch
Italiano
Español
Nederlands
Русский

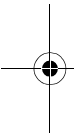

Pulsar Series

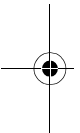



www.eaton.com

EX
700 - 1000
1000 RT -
EXB 1000
EXB 1000

**Installation
manual**

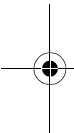

Pulsar Series

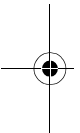



Thank you for selecting an EATON product to protect your electrical equipment.

The **EX** range has been designed with the utmost care.

We recommend that you take the time to read this manual to take full advantage of the m
(**U**ninterruptible **P**ower **S**ystem).

Before installing **EX**, please read the booklet on the required safety instructions. Then fo
manual.

To discover the entire range of EATON products and the options available for the **EX** rang
web site at www.eaton.com or contact your EATON representative.

Environmental protection

EATON has implemented an environmental-protection policy.
Products are developed according to an eco-design approach.

Substances

This product does not contain CFCs, HCFCs or asbestos.

Packing

To improve waste treatment and facilitate recycling, separate the various packing compo

- ▶ The cardboard we use comprises over 50% of recycled cardboard.

- ▶ Sacks and bags are made of polyethylene.

- ▶ Packing materials are recyclable and bear the appropriate identification symbol



PET

| Material | Abbreviation | Symbol number |
|----------------------------|--------------|---------------|
| Polyethylene terephthalate | PET | 01 |
| High-density polyethylene | HDPE | 02 |
| Polyvinyl chloride | PVC | 03 |
| Low-density polyethylene | LDPE | 04 |
| Polypropylene | PP | 05 |
| Polystyrene | PS | 06 |

Follow all local regulations for the disposal of packing materials.

End of life

EATON will process products at the end of their service life in compliance with local regu
EATON works with companies in charge of collecting and eliminating our products at the

Product

The product is made up of recyclable materials.

Dismantling and destruction must take place in compliance with all local regulations con

At the end of its service life, the product must be transported to a processing centre for elec

Battery

The product contains lead-acid batteries that must be processed according to applicable lo
batteries.

The battery may be removed to comply with regulations and in view of correct disposal

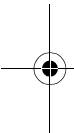



Introduction

Pictograms



Important instructions that must always be followed.



Information, advice, help.



Visual indication.



Action.



Audio signal.

In the illustrations on the following pages, the symbols below are used:



LED off



LED on



LED flashing

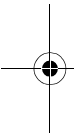



1. Presentation

1.1 Standard positions

Tower position

Rack position

1.2 Rear panels

EX 700 / 1000 / 1500

EX 1000 RT / 1500 RT

EX EXB (optional battery module)

EX EXB RT (optional battery module)

1.3 Control panel

2. Installation

2.1 Unpacking and contents check

2.2 Installation of the RT model in tower position

2.3 Installation of the RT model in a rack

2.4 Communication ports

Connection of RS232 or USB communication port (optional)

Installation of the communication cards (optional)

2.5 Characteristics of the contact communication port

2.6 Connection with a FlexPDU (Power Distribution Unit) module

2.7 Connection with a HotSwap MBP module

HotSwap MBP-module operation

2.8 UPS connection without a FlexPDU or HotSwap MBP module

3. Operation

3.1 Start-up and normal operation

3.2 Operation on battery power

3.3 Return of AC power

3.4 UPS shutdown

3.5 Using the UPS remote control functions

4. Access to measurements and personalisation data

4.1 Display menus arrangement

4.2 Access to measurements

4.3 Personalisation using the control panel

4.4 Personalisation using external software

5. Maintenance

5.1 Troubleshooting

Troubleshooting a UPS equipped with the HotSwap MBP module

5.2 Battery-module replacement

Safety recommendations

Battery-module removal

Mounting the new battery module

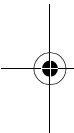



1. Presentation

1.1 Standard positions

Tower position

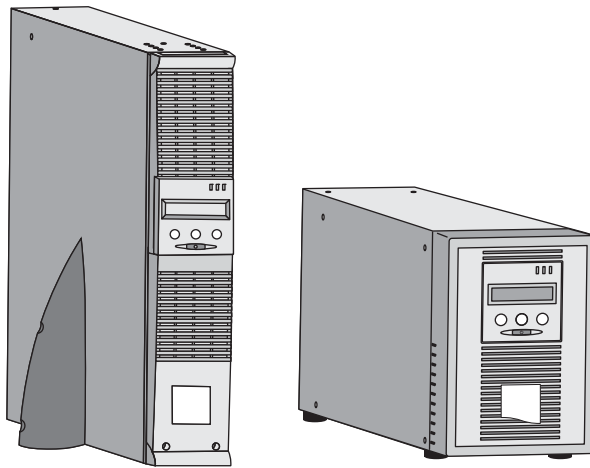

| Dimensions (H x W x D) | |
|------------------------|---|
| EX 700 | 2 |
| EX 1000 | 2 |
| EX 1000 RT | 8 |
| EX 1500 | 2 |
| EX 1500 RT | 8 |
| EX EXB | 2 |
| EX EXB RT | 8 |

| Weights in kg | |
|---------------|---|
| EX 700 | 1 |
| EX 1000 | 1 |
| EX 1000 RT | 1 |
| EX 1500 | 1 |
| EX 1500 RT | 2 |
| EX EXB | 2 |
| EX EXB RT | 2 |

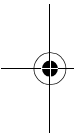

Rack position

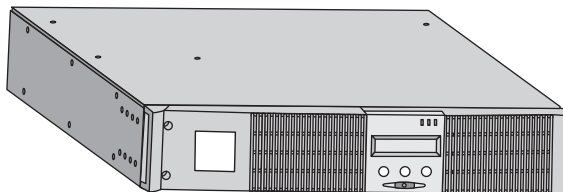



1.2 Rear panels

EX 700 / 1000 / 1500

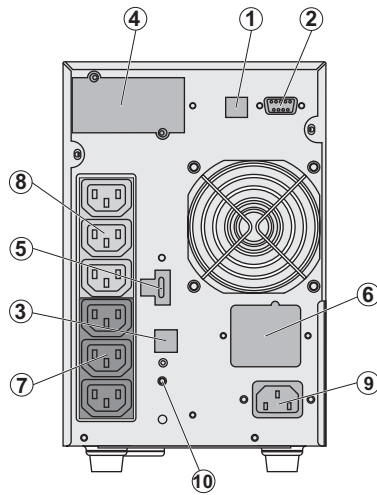

- (1) USB commu
- (2) RS232 and o
- communication
- (3) Connector fo
- a battery EXB m
- (4) Slot for opti
- (5) Connector fo
- (Remote Power
- (6) Connector fo
- (7) Group of 3 p
- connection of e
- (8) Group of 3 c
- equipment
- (9) Socket for co
- source
- (10) LED (SWF)
- system phase/n

EX 1000 RT / 1500 RT

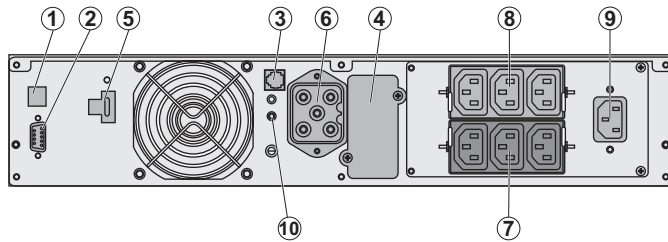

EX EXB (optional battery module)

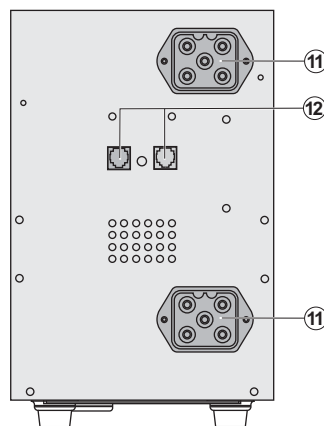

- (11) Connectors
- the UPS or to th
- (12) Connectors
- of battery modu



1. Presentation

EX EXB RT (optional battery module)

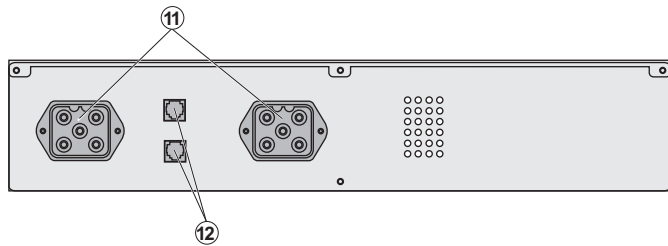

1.3 Control panel

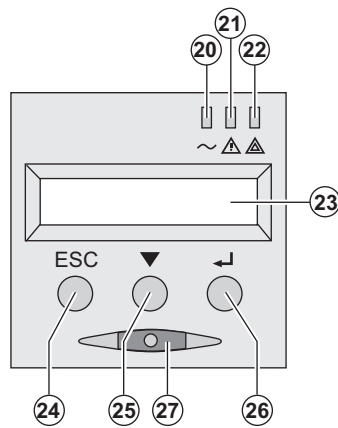

- (20) Load protected LED
- (21) Downgraded operation LED
- (22) Load not protected LED
- (23) Alphanumeric display
- (24) Escape (cancel) button
- (25) Scroll button
- (26) Enter (confirm) button
- (27) ON/OFF button for U

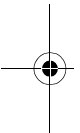



2.1 Unpacking and contents check

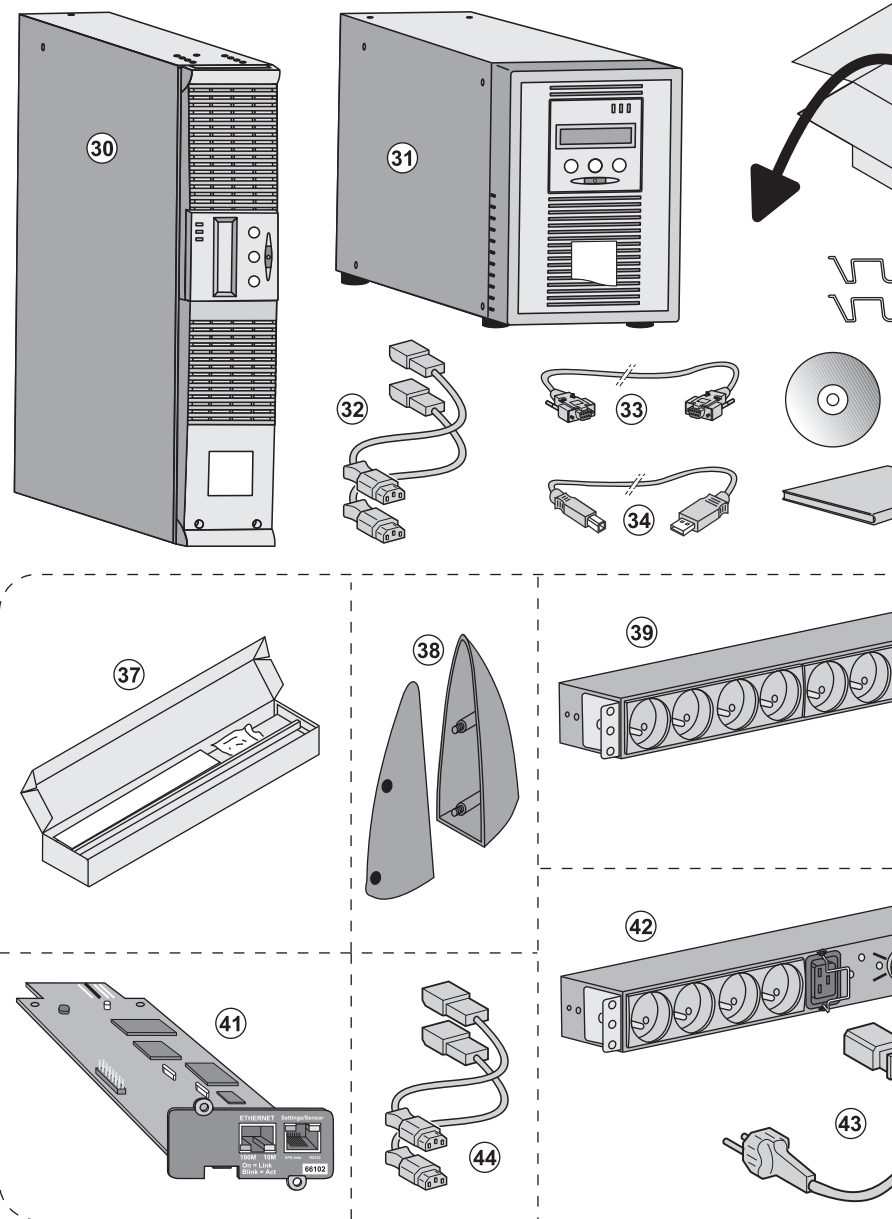

(30) EX 700, 1000, 1500

(31) EX 1000 RT, 1500 RT

(32) 2 connection cables for the protected equipment

(33) RS232 communication cable

(34) USB communication cable

(35) Securing system for equipment power cords

Elements supplied depending on

(37) Mounting kit for 19-inch ba

(38) 2 supports for the upright p

(39) FlexPDU module (optional)

(40) Connection cable between

(41) NMC communication card



2. Installation

2.2 Installation of the RT model in tower position

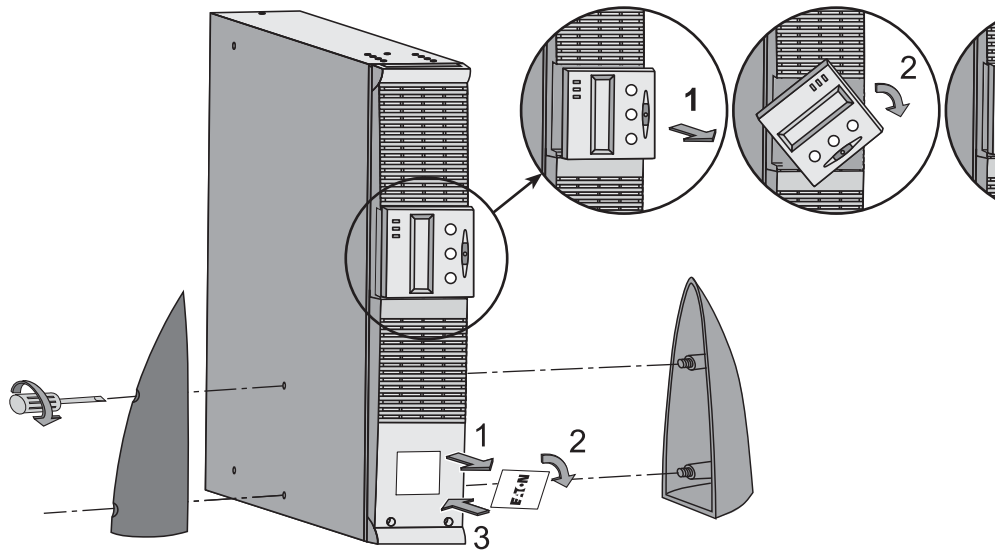

2.3 Installation of the RT model in a rack

It is advised to install the battery EXB module(s) at the lowest position in the rack, then install the



Follow steps 1 to 4 for module mounting on the rails.

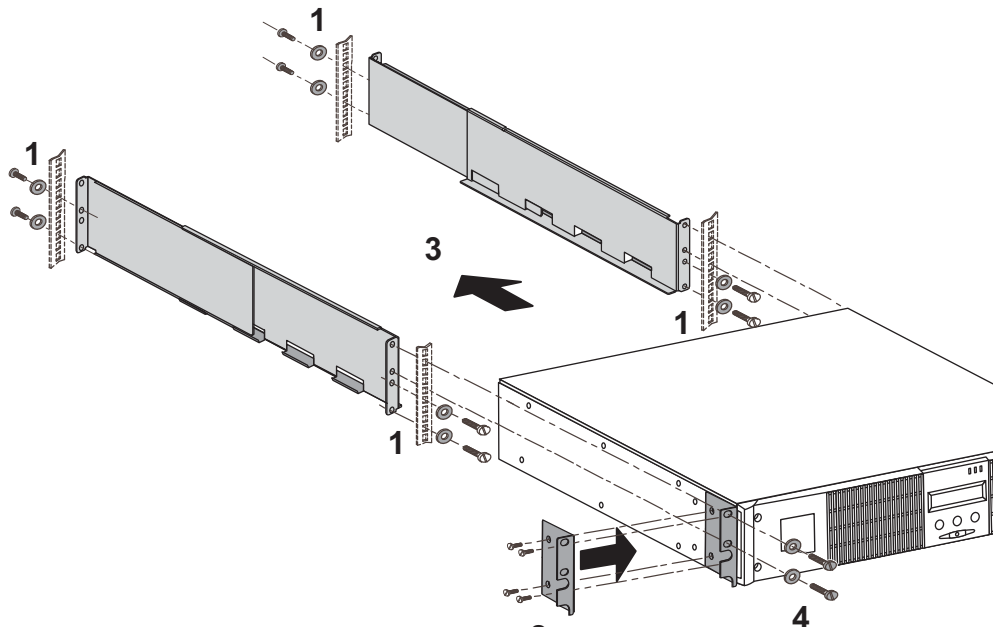



2.4 Communication ports

Connection of RS232 or USB communication port (optional)



The RS232 and USB communication ports cannot operate simultaneously.



Tower model

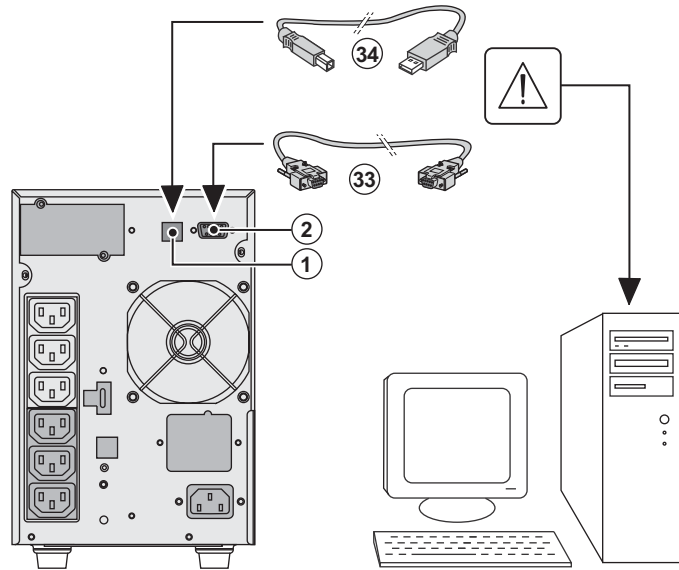

1 - Connect the communication port on the computer.

2 - Connect the communication port (USB (1) or RS232 (2)) on the UPS.

The UPS can not be connected to an EATON power supply.

RT model

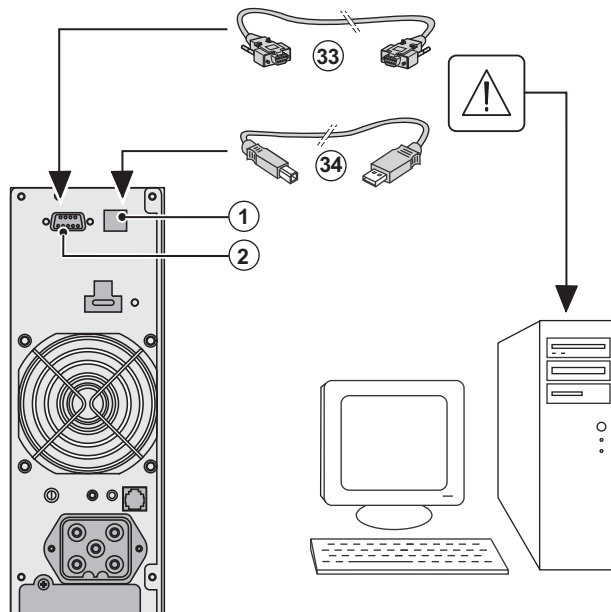

2. Installation

Installation of the communication cards (optional)

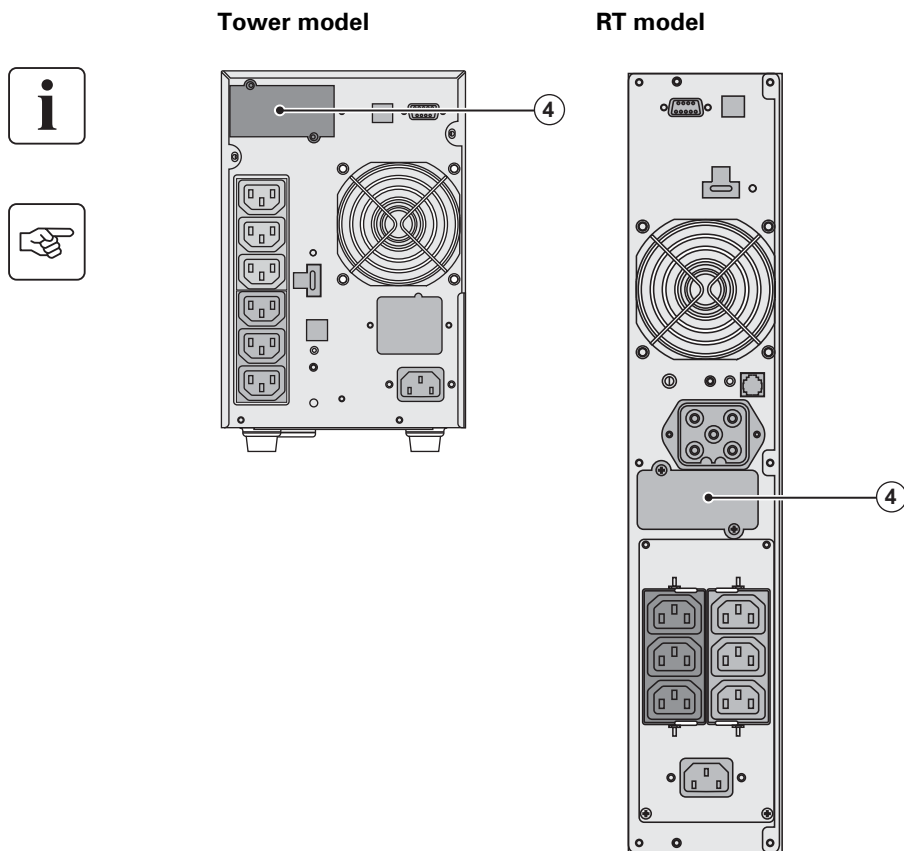

2.5 Characteristics of the contact communication port (2)

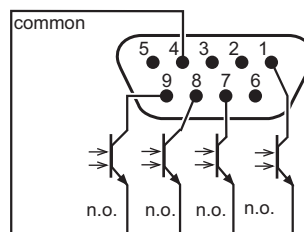

- Pin 2, 3, 5 and 6 : not used,
- Pin 1 : operation on automatic by-pass,
- Pin 4 : user common,
- Pin 7 : low battery,
- Pin 8 : load protected,
- Pin 9 : operation on battery.

n.o.: contact normally open.

When the status is active, the contact between the common (Pin 4) and the relevant information pin is closed.

Contact characteristics (optocoupler)

- Voltage: 48 V DC max,
- Current: 25 mA max,
- Power: 1.2 W.



2.6 Connections with a FlexPDU (Power Distribution Unit) module (optional)

RT model

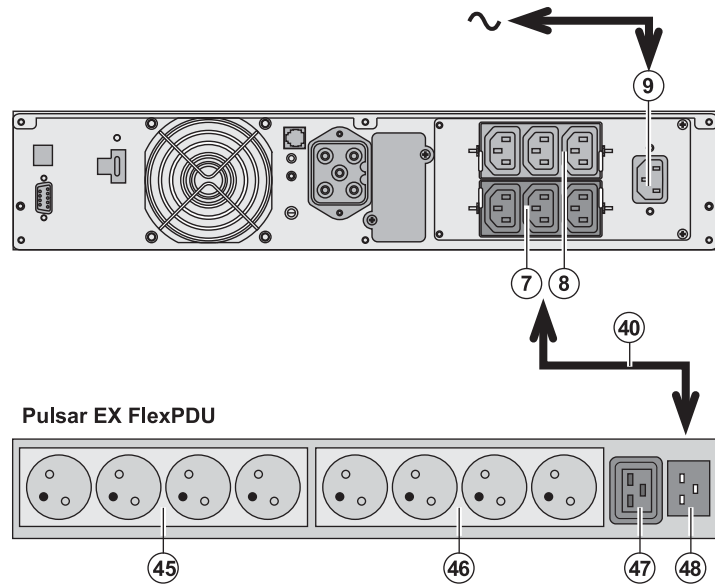

1 - Connect the power source to the equipments.

2 - Connect the FlexPDU module (8) using the cable supplied. The cable and terminals are in red.

3 - Connect the FlexPDU module (45), (46) and (47). These outlets depend on the version of the FlexPDU.

4 - Fit the connector (48) to prevent the plug from being inserted accidentally.

2.7 Connections with a HotSwap MBP module (optional)

The **HotSwap MBP** module makes it possible to service or even replace the UPS without loads (**HotSwap** function).

RT model

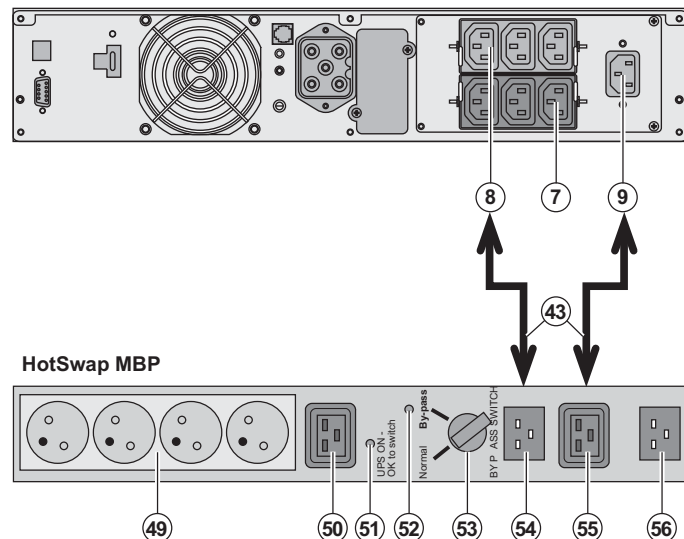

1 - Connect the HotSwap MBP module to the power source using the cable supplied.

2 - Connect the "UPS Input" (55) to the HotSwap MBP module, using the cable supplied. This cable and terminals are in blue.

3 - Connect the "UPS Output" (54) on the HotSwap MBP module using the cable supplied and the connector (56). To power the HotSwap MBP module, use the 10A FRN connector (53). If the AC-power is not used, use the 10A BS connector (52).



2. Installation

HotSwap MBP-module operation

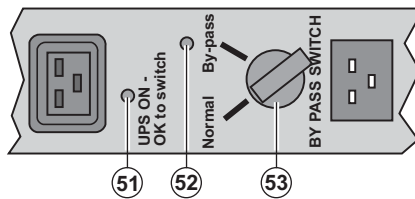

The **HotSwap MBP** module has a rotary switch (53) with two positions: **Normal** - the load is supplied by the UPS. **Bypass** - the load is supplied by the AC-power source.

UPS start-up with the HotSwap MBP module

- 1 - Check that the UPS is correctly connected to the **HotSwap MBP** module.
 - 2 - Set switch (53) to the Normal position.
 - 3 - Start the UPS by pressing the ON/OFF button (27) on the UPS control panel.
- The load is supplied by the UPS.
LED (51) "UPS ON - OK to switch" on the **HotSwap MBP** module goes ON.

HotSwap MBP-module test

- 1 - Set switch (53) to the Bypass position and check that the load is still supplied.
- 2 - Set switch (53) back to the Normal position.

2.8 UPS connection without a FlexPDU or HotSwap MBP module



Check that the indications on the name plate located on the back of the UPS correspond to the load capacity and the true electrical consumption of the total load.

Tower model

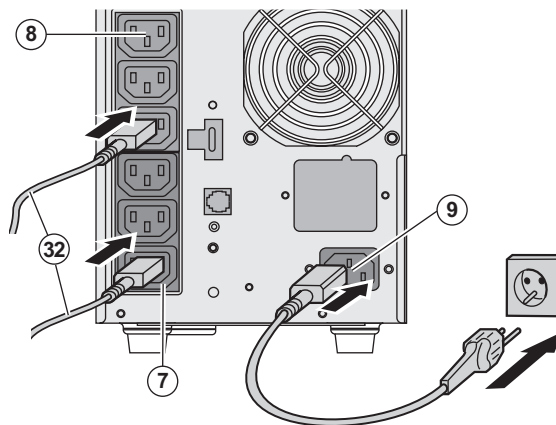

1 - Connect the UPS socket to the AC power source using the power cables (32).
2 - Connect the loads to the output power outlets (7) using the power cables (32).
It is preferable to connect the priority loads to the 3 outlets marked (8).
To program the outlets, use the communications software.

RT model

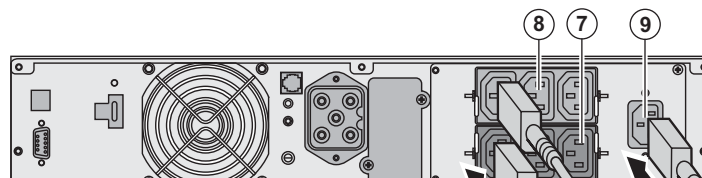



3.1 Start-up and normal operation



For the initial start, AC power must be present to detect any wiring errors. Subsequently, AC power is not present.

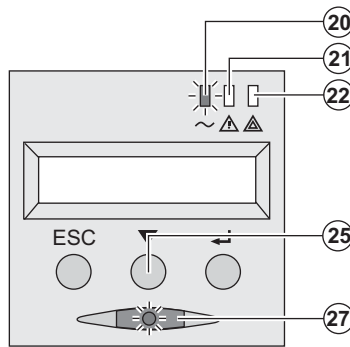

Press button (27) for approximately 1 second.

- ▶ The buzzer beeps once and all the LEDs (20, 21, 22) go ON.
- ▶ The buzzer then beeps twice during the start-up. If LED (22) remains ON, indicating that the load output is not correct.

The connected devices are protected by the UPS.

- ▶ LED (20) is ON.
- ▶ If LED (22) is ON, a fault has occurred (see the Troubleshooting section).
- ▶ During normal operation, the scroll button (27) displays the UPS measurements (AC input voltage, output voltage, output capacity and UPS serial number).

UPS personalisation



If UPS personalisation is desired, it is advised to enter the personalisation mode at this time. This mode may be entered using the buttons on the control panel or the **Personal Solution** software included on the **Solution-Pac** CD-ROM provided by EATON.

3.2 Operation on battery power

Transfer to battery power

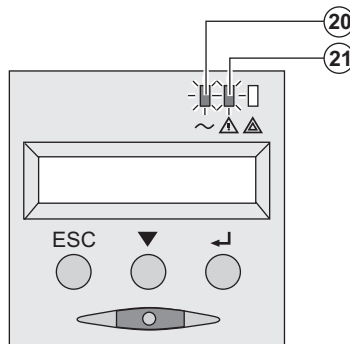

- ▶ The connected devices continue to be supplied by the battery. If the battery power is no longer available, the necessary devices will be disconnected from the battery.
- ▶ LEDs (20) and (21) go ON.
- ▶ The audio alarm beeps every ten seconds.

The connected devices are supplied by the battery.
The display indicates the remaining battery power.

Low-battery warning

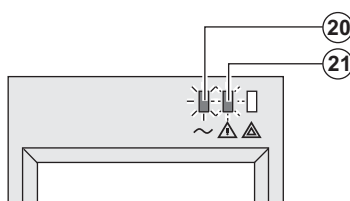

- ▶ LEDs (20) and (21) go ON.
- ▶ The audio alarm beeps every three seconds.

The remaining battery power is low.



3. Operation

End of battery backup time



- ▶ All the LEDs go OFF.
- ▶ The audio alarms stops.



The UPS is completely shut down.

3.3 Return of AC power

Following an outage, the UPS restarts automatically when AC power returns (unless the restart function is disabled via UPS personalisation) and the load is again supplied.

3.4 UPS shutdown

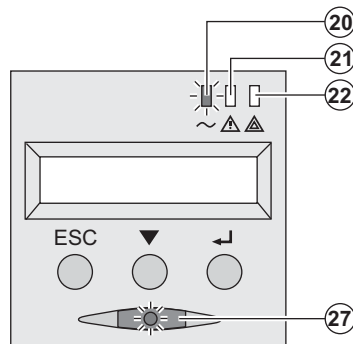

Press button (27) for approximately 2 seconds.

The devices connected to the UPS are no longer supplied.

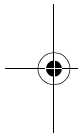

3.5 Using the UPS remote control functions

EX has the choice of two remote control options.

- ▶ **RPO: Remote Power Off** allows a remote contact to be used to disconnect all the equipment connected to the power supply.

Restarting the UPS requires manual intervention.

- ▶ **ROO: Remote ON/OFF** allows remote action of button (27).

These functions are obtained by opening a contact connected between the appropriate pins of the rear panel of the UPS (see diagram on following page).



RT model

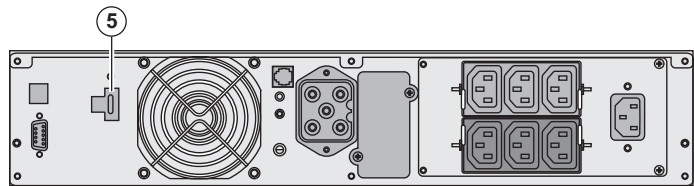

Tower model

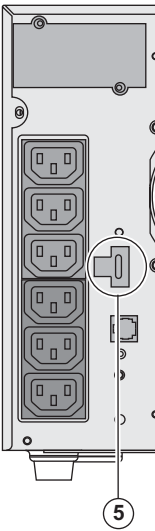

Remote control connection and test



- 1 - Check the UPS is shut down and the electrical supply network disconnected.
- 2 - Remove connector (5) by unfitting the screws.
- 3 - Connect a normally closed volt-free contact (60 Vdc / 30 Vac max, 20 mA max, 0.75 mW max) between the two pins of connector (5), see diagram.

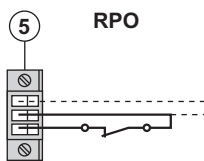
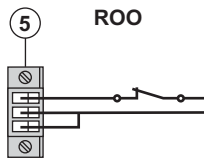

ROO
 Contact open: shut down of UPS
 Contact closed: start-up of UPS (UPS connected to the network)

Note: local On/Off control via button (27) has priority over the remote control.

RPO
 Contact open: shut down of UPS
 To return to normal operation, deactivate the external remote shutdown contact and restart the UPS using button (27).

- 4 - Plug connector (5) into the back of the UPS.
- 5 - Connect and restart the UPS according to the previously described procedures.
- 6 - Activate the external remote shut down contact to test the function.



Warning: this connector must only be connected to SELV (Safety Extra Low Voltage) circuit.



4. Access to measurements and personalisation data

4.1 Display menus arrangement

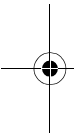
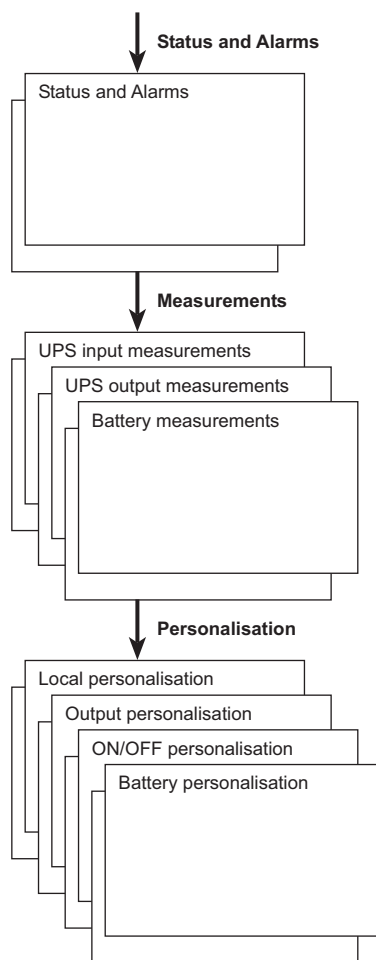

4.2 Access to measurements

Press the scroll button **(25)** to access any status conditions and alarms, then the measurements for frequency, power output and battery backup time.

4.3 Personalisation using the control panel

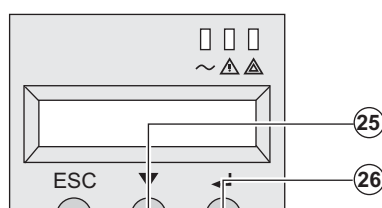

- Press the scroll button **(25)** several times until the menu is reached.
- Press the Enter button **(26)** to access the different options.
- Finally, confirm the selection by pressing the Enter button **(26)** again.



4. Access to measurements and personalisation

Output personalisation

| Function | Factory setting | Other available settings | Comments |
|--|---|---|---|
| Output voltage ⁽¹⁾ | 230 Volts AC | 200/208/220/240/250 Volts AC | |
| Frequency converter ⁽¹⁾ | Disabled | Enabled | The converter is always enabled when the output is transferred to the bypass. |
| Output frequency ⁽¹⁾ | Automatic selection | 50 or 60 Hz | User selection is only possible when the frequency converter is enabled. |
| Transfer to the bypass AC input ⁽¹⁾ | Bypass AC power must be within tolerances | Bypass AC power may be outside tolerances | |
| Overload level ⁽¹⁾ | 100% | 30 / 50 / 70% | Alarm if exceeded. |

(1) These parameters may be modified only when the **UPS** is OFF.
Detailed comments are available in the **Personal Solution-Pac** software.

ON/OFF personalisation

| Fonction | Personnalisation usine | Autres choix | Commentaires |
|--|------------------------|--------------|--|
| Start on battery power | Enabled | Disabled | |
| Automatic restart | Enabled | Disabled | The UPS restarts automatically when AC is restored. |
| Energy savings | Disabled | Enabled | When enabled, the UPS shuts down when the battery level is <5%. |
| Detection of phase/neutral inversion (SWF) | Disabled | Enabled | When enabled, the UPS remains in bypass mode when a phase/neutral inversion is detected. |

Battery personalisation

| Function | Factory setting | Other available settings | Comments |
|---|--|-------------------------------------|--------------------------------------|
| Battery test | Weekly test | No test / daily test / monthly test | |
| Low-battery warning | 20% | 0 to 100% | Adjustable. |
| Selection of the backup time | Automatic detection of number of battery modules | 13 to 200 Ah | |
| Battery protection against excessive discharges | Enabled | Disabled | When disabled, the warranty is void. |

4.4 Personalisation using external software



5. Maintenance

5.1 Troubleshooting



If LED (21) or (22) is ON, a fault or an alarm has occurred.
Use the escape button (24) to stop the audio alarm.

| | Indication | Diagnostic | Correction |
|---|---|---|---|
| 1 | The UPS does not start, the alphanumeric display indicates: COLD START NOK CHECK AC WIRING | The AC input power is not connected or is connected to the UPS output. | Check the UPS is connected to the |
| 2 | LED (22) is ON, the SWF LED (11) at the rear of the UPS is ON. The alphanumeric display indicates: SITE WIR. FAULT CHECK AC WIRING | Phase inversion on AC input power. The UPS does not start. | <ul style="list-style-type: none"> ►In an earthed-network, correct the wiring (turn the AC-power (DIN-SCHUKO type) electrician to modify connections. ►For all other type, disable the detect |
| 3 | LED (22) is ON, the alphanumeric display indicates: NO BATTERY CHECK CONNECTION | The battery is incorrectly connected. | Check battery connection (section 5.2, Battery replacement). |
| 4 | LED (22) is ON, the alphanumeric display indicates: BATTERY FAULT SERV REQUIRED | A fault is detected on the battery. | Replace the battery (section 5.2, Battery-module). Call the after-sales department. |
| 5 | LED (21) is ON, the alphanumeric display indicates: OVERLOAD ALARM REDUCE LOAD | The load level exceeds the programmed overload level or UPS capacity. | Check the power connected device (any non-priority of the programmed |
| 6 | LED (22) is ON, the alphanumeric display indicates: LOAD UNPROTECTED OUTPUT OVERLOAD | The UPS is overloaded. Devices connected to the UPS are fed directly by the electrical network via the By-pass. | Check the power connected device (any non-priority of |
| 7 | LED (22) is ON, the alphanumeric display indicates: REDUCE LOAD RESTART UPS | After repetitive overloads, the UPS is locked in the By-pass position. Devices connected to the UPS are fed directly by the electrical network. | Check the power connected device (any non-priority of). Shut down and return to normal |
| 8 | LED (22) is ON, the alphanumeric display indicates: OVERLOAD FAULT REDUCE LOAD | The UPS shut down automatically because of overload at the UPS output. | Check the power connected device (any non-priority of |
| 9 | LED (22) is ON, the alphanumeric display indicates: LOAD SHORT-CIRCU CHECK WIRING | The UPS shut down automatically because of a short-circuit at the UPS output. | Check the installation output (wiring, fa |

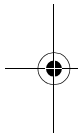



Troubleshooting a UPS equipped with the HotSwap MBP module



| | Indication | Diagnostic | Corrective action |
|----|--|--|--|
| 12 | The load is no longer supplied when the rotary switch (49) on the HotSwap MBP module is set to the Bypass position. | <ul style="list-style-type: none"> ▶ The protected devices are connected to the UPS output instead of to the HotSwap MBP module. ▶ The AC-power cord is connected to the UPS input instead of to the HotSwap MBP module. | Check the wiring and the load (see section 5.1). |
| 13 | The load is no longer supplied when the rotary switch (49) on the HotSwap MBP module is set to the Normal position. | <ul style="list-style-type: none"> ▶ The UPS is shut down. ▶ The wiring between the UPS and the HotSwap MBP module is not correct. | <ul style="list-style-type: none"> ▶ Start the UPS. ▶ Check the wiring between the UPS and the module. |
| 14 | The load is no longer supplied if AC-power fails. | <ul style="list-style-type: none"> ▶ The rotary switch (49) on the HotSwap MBP module is set to the Bypass position. ▶ The wiring between the UPS and the HotSwap MBP module is not correct. | <ul style="list-style-type: none"> ▶ Set the rotary switch to the HotSwap MBP Normal position. ▶ Check the wiring between the UPS and the module. |

If a fault leads to UPS shutdown, press the ON/OFF button (27) to clear the fault.

5.2 Battery-module replacement

Safety recommendations

The battery can cause electrocution and high short-circuit currents. The following safety recommendations must be followed before servicing the battery components:

- ▶ Remove watches, rings, bracelets and all other metal objects from the hands and arms.
- ▶ Use tools with an insulated handle.

Battery-module removal

RT model

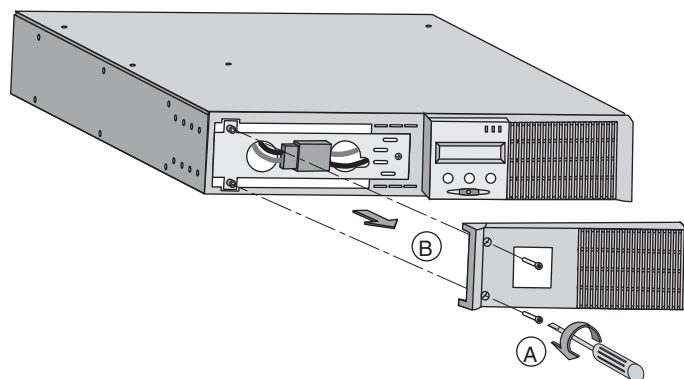

- A - Unscrew the panel (two screws).
- B - Remove the battery module.



5. Maintenance

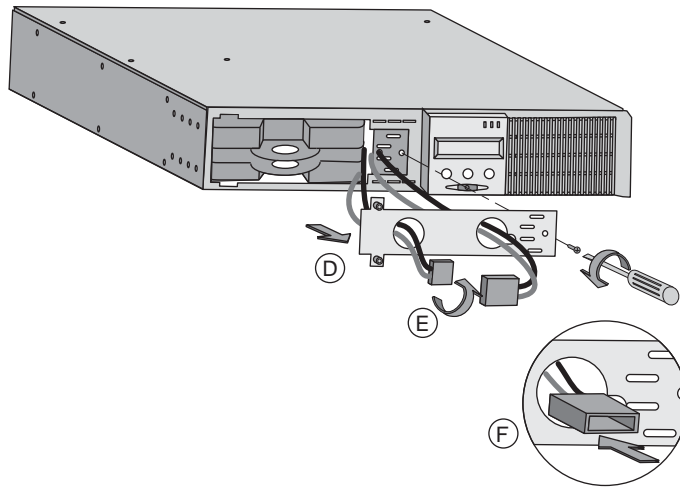

D - Remove the metal pr
front of the battery (two
E - Turn the connector.
F - Pass the connector th

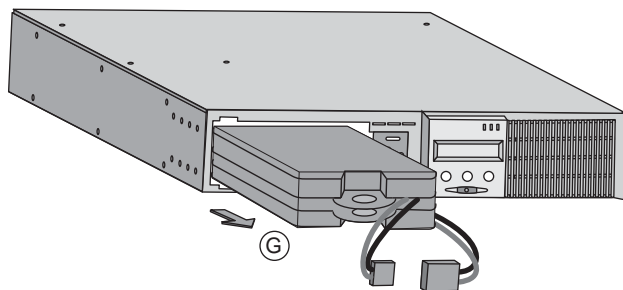

G - Pull the plastic tab to
battery block and replac

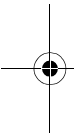

Tower model

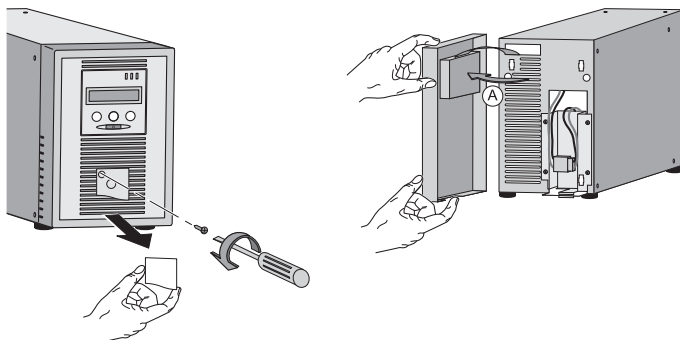

A - Put the front panel ne

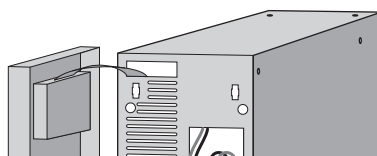

B - Disconnect the batter
separating the two conn
on the wires).



5.

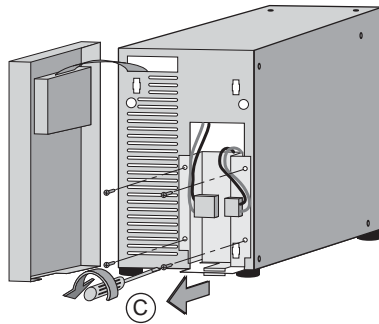

C - Remove the protection cover.

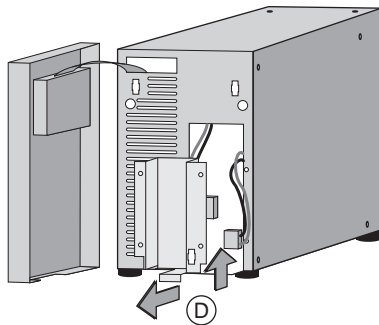

D - Remove the battery.

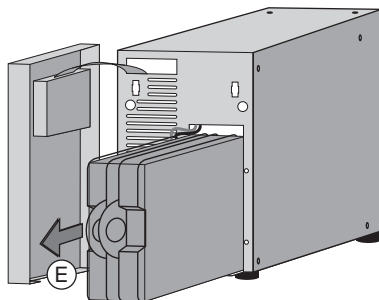

E - Pull the plastic battery block out.

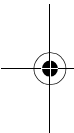

Mounting the new battery module

Carry out the above instructions in reverse order.



- ▶ To ensure safety and high performance, use only batteries supplied by EATON.
- ▶ Take care to firmly press together the two parts of the connector during remounting.



5. Maintenance

5.3 Maintenance on a UPS equipped with the HotSwap MBP module

RT model

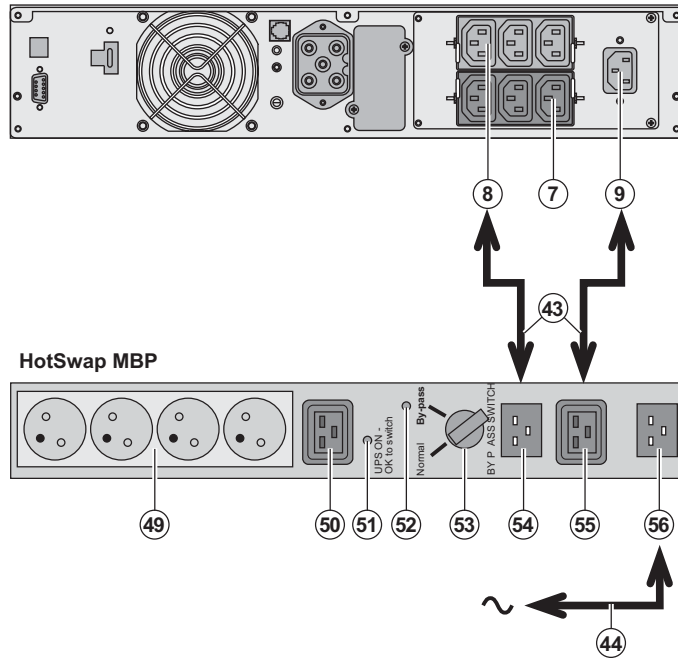

The **HotSwap MBP** module allows it to be possible to service or even replace the UPS without affecting the operation of the UPS (HotSwap function).

Maintenance:

- 1 - Set switch (53) to the **Normal** position. The red LED (52) on the HotSwap MBP module goes ON, indicating that the UPS is supplied directly with the AC input.
- 2 - Stop the UPS by pressing the Stop button (27) on the UPS control panel. The red LED (52) "UPS ON - OK to switch" goes OFF. The UPS can now be disconnected and replaced.

Return to normal operation:

- 1 - Check that the UPS is properly connected to the **HotSwap MBP** module.
- 2 - Start the UPS by pressing the Start button (27) on the UPS control panel. The red LED (52) "UPS ON - OK to switch" goes ON. The **HotSwap MBP** module goes into bypass mode (otherwise, there is a connection between the **HotSwap MBP** module and the UPS).
- 3 - Set switch (53) to the **Bypass** position. The red LED (52) on the HotSwap MBP module goes OFF.
- 4 - The equipments are protected by the UPS.

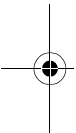

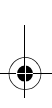

5.4 Training centre



To fully master operation of your EATON product and carry out level 1 servicing, see our training courses, available in both French and English.

For further information, please visit our website: www.eaton.com

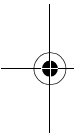



6. Appendices

6.1 Technical specifications

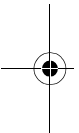
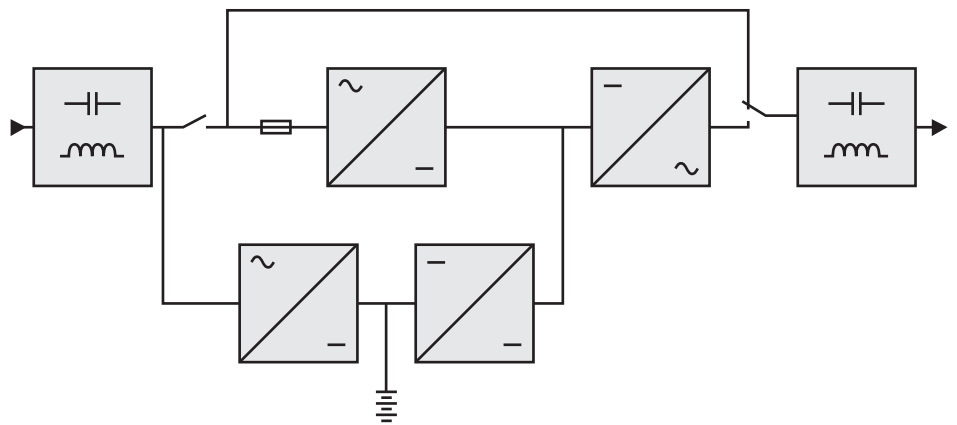

| | EX 700 | EX 1000 EX 1000 RT | EX 1500 EX 1500 RT |
|------------------------------------|--|---|---|
| Output power | 700 VA / 630 W | 1000 VA / 900 W ⁽³⁾ | 1500 VA / 1350 W ⁽⁴⁾ |
| AC input power | Single phase 100 / 120 / 140 V / 160 V / 184 V to 284 V ⁽⁵⁾ | | |
| ▶ Voltage | 50/60 Hz (autoselection) | | |
| ▶ Frequency | > 0.95 | | |
| ▶ Power factor | | | |
| Load output | Single phase 230 V ±3% ⁽⁶⁾ | | |
| ▶ Voltage | 50/60 Hz ±0.5% ⁽⁷⁾ | | |
| ▶ Frequency | < 4% for linear load, < 6% for nonlinear load | | |
| ▶ Harmonic distortion (THDV) | 102% continuous, 130% 12 s, > 130% 2 s | | |
| ▶ Overload capacity | | | |
| ▶ Current | 3 A ⁽⁸⁾ | 4.3 A ⁽⁸⁾ | 6.5 A ⁽⁸⁾ |
| Battery | 2x12 V - 7 Ah, sealed lead acid, maintenance free | 3x12 V - 7 Ah, sealed lead acid, maintenance free | 3x12 V - 9 Ah, sealed lead acid, maintenance free |
| Environment | < 38 dBA | | |
| ▶ Noise level | 0°C to 40°C | | |
| ▶ Operating temperature range | 20% to 90% (without condensation) | | |
| ▶ Relative humidity | < 1,1 mA | | |
| ▶ Leakage current | -25°C to 40°C | | |
| ▶ Storage temperature range | 1000 m | | |
| ▶ Altitude | | | |
| Standards and certification | IEC/EN 62040-1-1, EN 60950-1 (RD) | | |
| ▶ Safety | IEC/EN 62040-3 | | |
| ▶ Performance | EN 50091-2/IEC 62040-2 class B, IEC 61000-4-2/-3/-4/-6-8/-11, | | |
| ▶ EMC | IEC 61000-3-2/-3 | | |
| ▶ Markings | | | |



6.2 Glossary

| | |
|--|--|
| Bypass AC input | Bypass line from the AC-power source, controlled by the UPS, load if an overload or a malfunction occurs on the UPS. |
| Backup time | Time during which the load can be supplied by the UPS operation. |
| Battery test | Internal UPS test to check battery status. |
| Equipments | Devices connected to the UPS output. |
| Excessive discharge | Battery discharge beyond the permissible limit, resulting in irreversible battery. |
| FlexPDU | Module with UPS outlets for installation in a bay. There are different types of outlets. |
| Frequency converter | Operating mode used to convert the AC-power frequency between output (50 Hz -> 60 Hz or 60 Hz -> 50 Hz). |
| HotSwap MBP | UPS manual-bypass module for maintenance. There are different types of outlets. |
| Low-battery warning | This is a battery-voltage level indicating that battery power is low. Take action in light of the imminent break in the supply of power. |
| Normal AC input | The AC-power line supplying the UPS under normal conditions. |
| Percent load | Ratio of the power effectively drawn by the load to the maximum power. |
| Personalisation | It is possible to modify certain UPS parameters set in the factory. It can also be modified by the Personal Solution-Pac software to adapt the UPS to the user's needs. |
| Programmable outlets | These outlets can be automatically shut down during operation (shutdown time delays can be programmed with the Personal Solution-Pac software). The UPS has two sets of two and one programmable outlets. |
| Start on battery power | The devices connected to the UPS can be started even when AC power is not available. The UPS operates only on battery power. |
| UPS | Uninterruptible Power System. |
| UPS ON/OFF controlled by software | This function enables or disables UPS ON/OFF control sequence through the management software. |

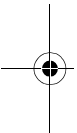

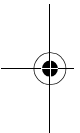



www.eaton.com

EX
700 - 1000
1000 RT -
EXB 1000
EXB 1000

**Manuel d'
et d'utilis**

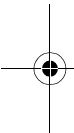

Pulsar Series

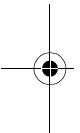



Nous vous remercions d'avoir choisi un produit EATON pour la sécurité de vos applications.

La gamme **EX** a été élaborée avec le plus grand soin.

Pour exploiter au mieux les performances de votre **ASI (Alimentation Sans Interruption)**, prendre le temps de lire ce manuel.

Avant l'installation de **EX**, lire le livret qui présente les consignes de sécurité à respecter. Suivre ensuite les instructions du présent manuel.

Nous vous invitons à découvrir l'offre de EATON ainsi que les options de la gamme **EX** en visitant notre site WEB : www.eaton.com, ou en contactant votre représentant EATON.

Respect de l'environnement

La société EATON s'est engagée dans une politique de protection et de préservation de l'environnement. Nos produits sont développés selon une démarche d'éco-conception.

Substances

Ce produit ne contient ni de CFC, ni de HCFC, ni d'amiante.

Emballage

Pour améliorer le traitement des déchets et faciliter le recyclage, séparez les éléments de l'emballage.

- Le carton est composé de plus de 50% de carton recyclé.
- Les sacs et sachets sont en polyéthylène.
- Les matériaux constituant l'emballage sont recyclables et marqués du symbole d'identification.

| Matériaux | Abbréviation | Numéro dans le symbole |
|----------------------------|--------------|------------------------|
| Polyéthylène Téréphthalate | PET | 01 |
| Polyéthylène Haute Densité | HDPE | 02 |
| Polyvinyle Chloride | PVC | 03 |
| Polyéthylène Basse Densité | LDPE | 04 |
| Polypropylène | PP | 05 |
| Polystyrène | PS | 06 |

Suivre les réglementations locales en vigueur pour l'élimination de l'emballage.

Fin de vie

La société EATON s'est engagée à traiter les produits en fin de vie selon les réglementations en vigueur. EATON travaille avec des sociétés en charge de la collecte et de l'élimination de nos produits.

Produit

Le produit est composé de matériaux recyclables.

Son démantèlement et sa destruction doivent se faire en accord avec les réglementations en vigueur concernant les déchets.

Le produit en fin de vie doit être déposé dans un centre de traitement des déchets électriques et électroniques.

Batterie

Le produit contient des batteries au plomb qui doivent être traitées suivant les réglementations en vigueur concernant les batteries.

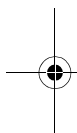



Introduction

Pictogrammes utilisés



Consignes à suivre impérativement.



Informations, conseils, aide.



Indication visuelle à observer.



Action à réaliser.



Signalisation sonore.

Les conventions adoptées pour représenter les voyants dans les illustrations sont les suivantes :



Voyant éteint.



Voyant allumé.



Voyant clignotant.

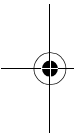



1. Présentation

1.1 Positions standards

Position tour

Position rack

1.2 Faces arrières

EX 700 / 1000 / 1500

EX 1000 RT / 1500 RT

EX EXB (module batterie optionnel)

EX EXB RT (module batterie optionnel)

1.3 Panneau d'affichage et de commande

2. Installation

2.1 Déballage et vérification du contenu

2.2 Installation du modèle RT en position tour

2.3 Installation du modèle RT dans un rack

2.4 Ports de communication

Raccordement du port de communication RS232 ou USB (facultatif)

Installation des cartes de communication (option)

2.5 Caractéristiques du port de communication par contacts

2.6 Raccordements avec un module FlexPDU (Power Distribution Unit)

2.7 Raccordements avec un module HotSwap MBP

Fonctionnement du module HotSwap MBP

2.8 Raccordements d'une ASI dépourvue de module FlexPDU ou HotSw

3. Utilisation

3.1 Mise en service et fonctionnement normal

3.2 Fonctionnement sur batterie

3.3 Retour du réseau électrique

3.4 Arrêt de l'ASI

3.5 Utilisation des fonctions de commande à distance de l'ASI

4. Accès aux mesures et personnalisation

4.1 Synoptique de l'afficheur

4.2 Accès aux mesures

4.3 Personnalisation par le panneau de commande

4.4 Personnalisation par logiciel externe

5. Maintenance

5.1 Dépannage

Dépannage d'une ASI équipée d'un module HotSwap MBP

5.2 Remplacement du module batterie

Rappel sur les consignes de sécurité

Démontage du module batterie

Remontage du nouveau module batterie

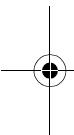



1. Présentation

1.1 Positions standards

Position tour

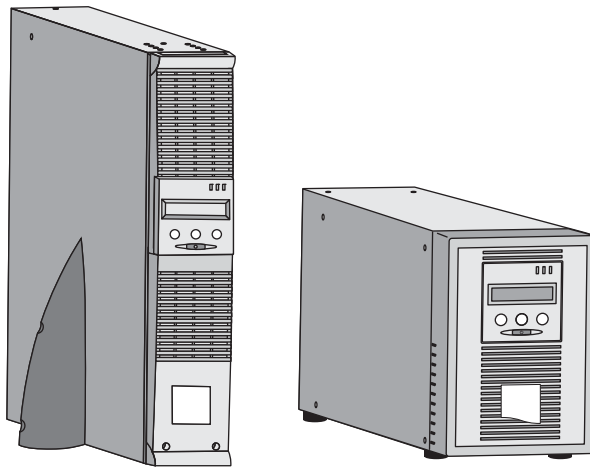

| Tableau des dimensions en mm | |
|------------------------------|---|
| EX 700 | 2 |
| EX 1000 | 2 |
| EX 1000 RT | 8 |
| EX 1500 | 2 |
| EX 1500 RT | 8 |
| EX EXB | 2 |
| EX EXB RT | 8 |

| Tableau des masses en kg | |
|--------------------------|---|
| EX 700 | 1 |
| EX 1000 | 1 |
| EX 1000 RT | 1 |
| EX 1500 | 1 |
| EX 1500 RT | 2 |
| EX EXB | 2 |
| EX EXB RT | 2 |

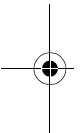

Position rack

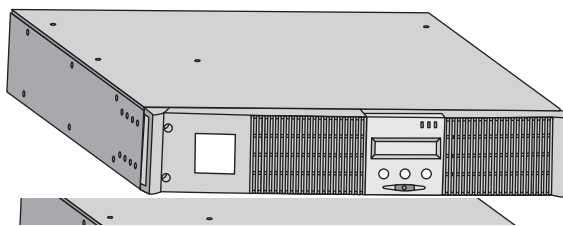



1.

1.2 Faces arrières

EX 700 / 1000 / 1500

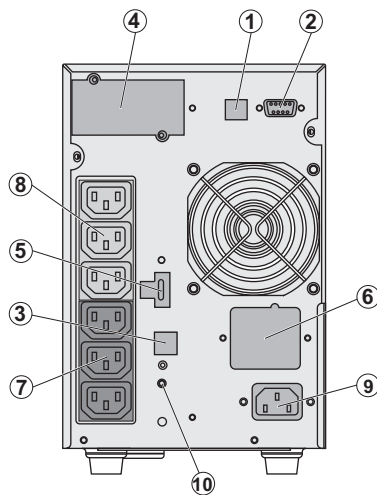

- (1) Port de com
- (2) Port de com
- contacts secs
- (3) Connecteur
- automatique d'
- (sauf EX 700)
- (4) Emplacement
- communication
- (5) Connecteur
- d'une commande
- d'un arrêt d'urg
- (6) Connecteur
- module batterie
- (7) Groupe de 3
- pour le raccord
- (8) Groupe de 3
- raccordement d
- (9) Prise pour le
- électrique d'alim
- (10) Voyant de s
- phase/neutre d

EX 1000 RT / 1500 RT

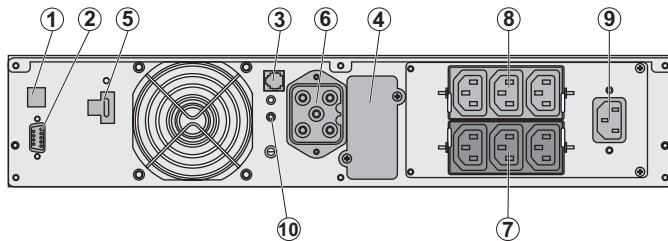
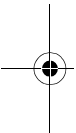

EX EXB (module batterie optionnel)

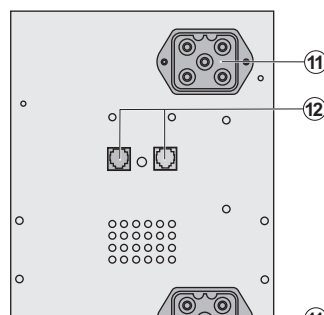

- (11) Connecteur
- des modules ba
- les autres modu
- (12) Connecteur
- automatique de



1. Présentation

EX EXB RT (module batterie optionnel)

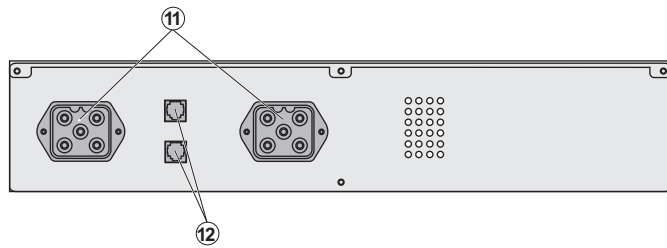

1.3 Panneau d'affichage et de commande

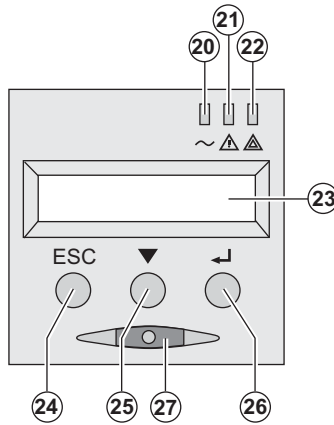

- (20) Voyant équipements
- (21) Voyant de fonctionn
- (22) Voyant équipements
- (23) Affichage alphanum
- (24) Bouton d'abandon,
- (25) Bouton de défileme
- (26) Bouton de validation
- (27) Bouton de commande
- (ON/OFF) de l'ASI et des

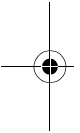



2.1 Déballage et vérification du contenu

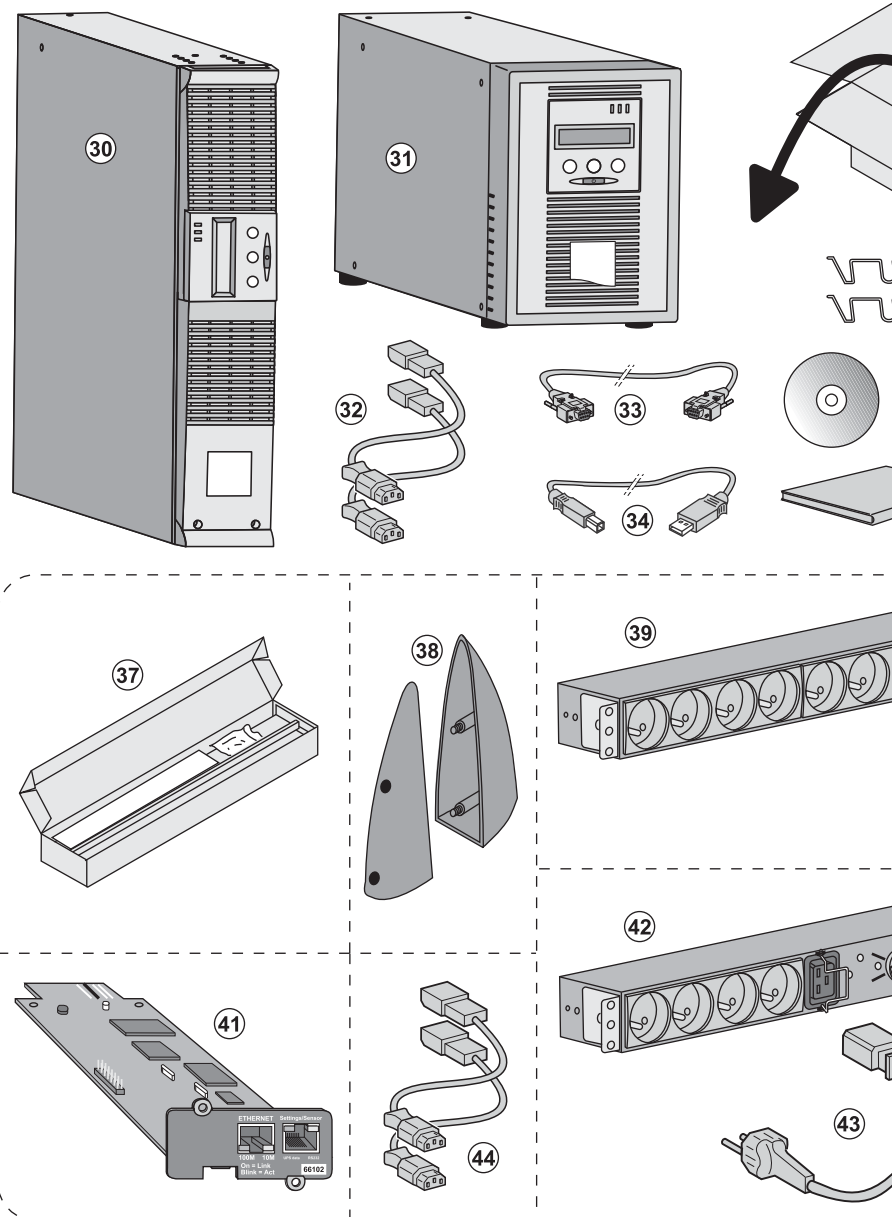

(30) EX 700, 1000, 1500.

(31) EX 1000 RT, 1500 RT.

(32) 2 cordons pour raccorder les équipements.

(33) Câble de communication RS232.

(34) Câble de communication USB.

(35) Système de verrouillage des cordons d'alimentation des équipements (modèle RT

Éléments fournis selon la version

(37) Kit de montage en armoire

(38) 2 Pieds de maintien en position (modèle RT seulement).

(39) Module FlexPDU (option).

(40) Cordon de raccordement de l'ASI.



2. Installation

2.2 Installation du modèle RT en position tour

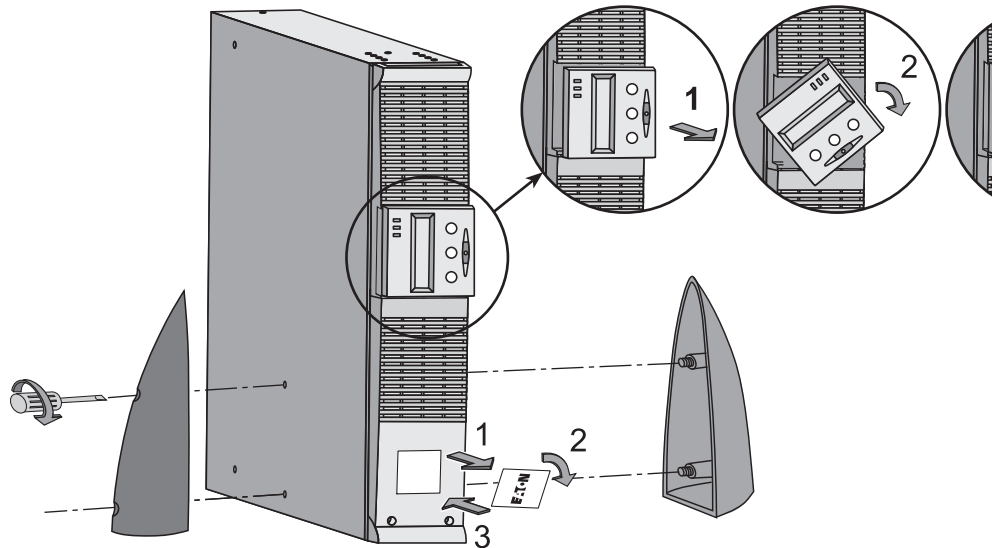

2.3 Installation du modèle RT dans un rack

Il est recommandé d'installer le ou les modules batterie EXB le plus bas possible dans le rack, et c'est le cas de ce modèle.

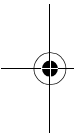

Suivre les étapes 1 à 4 pour le montage du module sur ses rails.

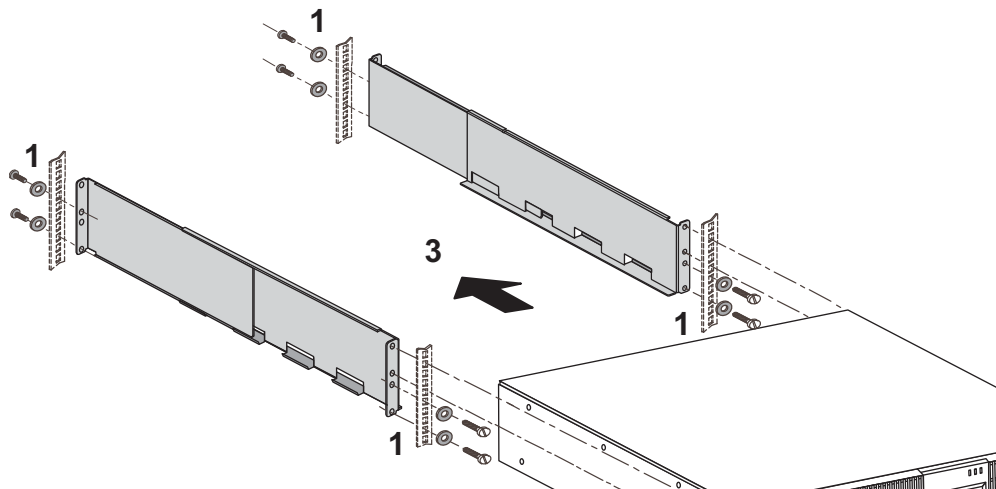



2.4 Ports de communication

Raccordement du port de communication RS232 ou USB (facultatif)



Le port de communication RS232 et le port de communication USB ne peuvent fonctionner simultanément.

Modèle Tour

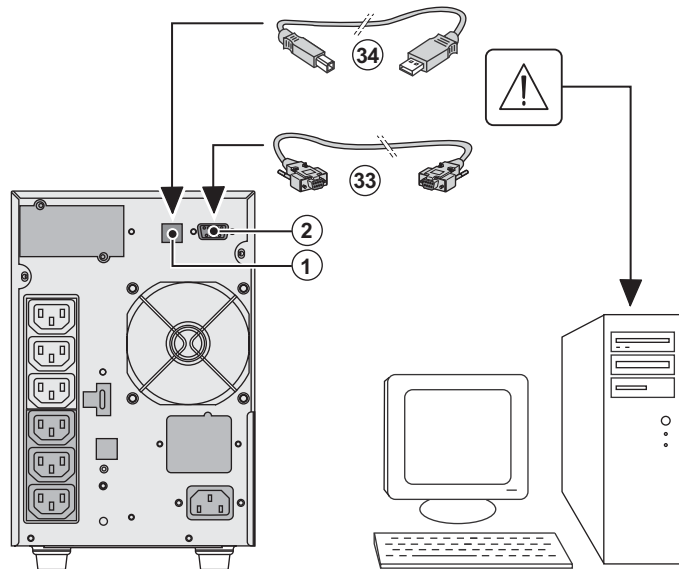

1 - Connecter le câble de communication RS 232 (33) ou le câble de communication USB de l'équipement.

2 - Connecter l'équipement de communication à l'ASI.

L'ASI peut désinstaller le logiciel d'administration personnalisé.

Modèle RT

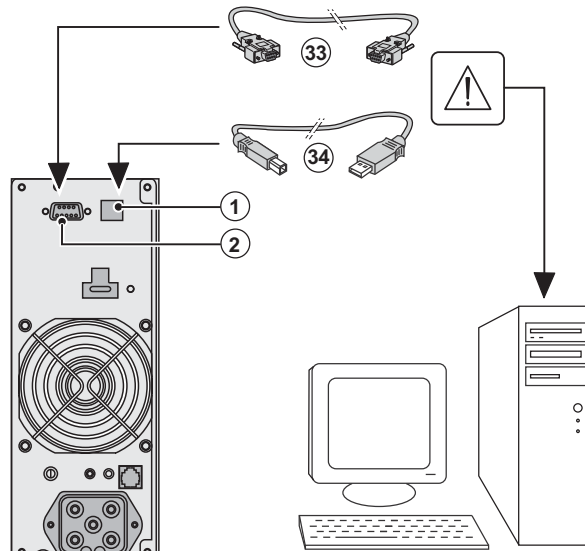



2. Installation

Installation des cartes de communication (en option)



Modèle Tour

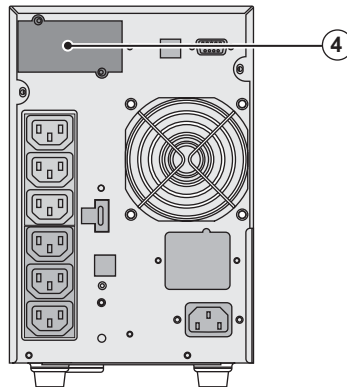

Modèle RT

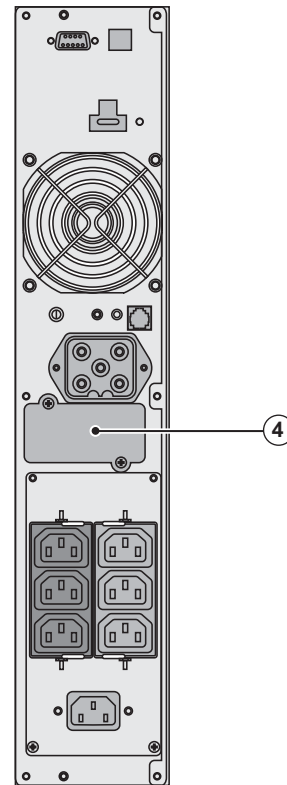

Il n'est pas nécessaire d'installer la carte de communication (4) : Emplacement, à accorder la carte de communication

- 1 - Oter le plastron (4) de vis.
- 2 - Insérer la carte de communication à l'emplacement prévu.
- 3 - Fixer le plastron de la vis.

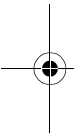

2.5 Caractéristiques du port de communication par contacts (2)

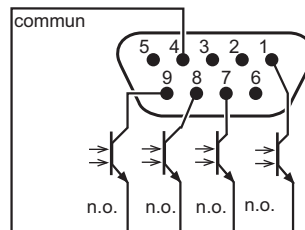

- Broches 2, 3, 5 et 6 : non utilisées,
- Broche 1 : fonctionnement sur Bypass automatique,
- Broche 4 : commun utilisateur,
- Broche 7 : préalarme de fin d'autonomie batterie,
- Broche 8 : applications utilisateur protégées,
- Broche 9 : fonctionnement sur batterie.

n.o. : contact normalement ouvert.

Quand une information est active, le contact est fermé entre la broche commune 4 et la broche de correspondante.

Caractéristiques des contacts (optocoupleurs)

- Tension : 48 V CC max,
- Courant : 25 mA max,
- Puissance : 1,2 W.



2.6 Raccordements avec un module FlexPDU (Power Distribution Unit)

Modèle RT

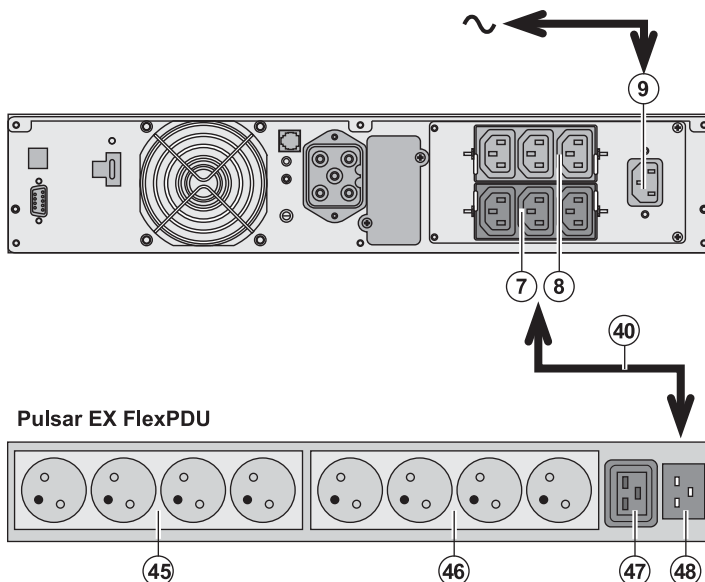

1 - Relier la prise réseau électrique d'alimentation à protéger.

2 - Relier la prise électrique du module de sortie (prise de sortie) à la prise de sortie (40) IEC. Ce câble et ces bornes sont de couleur rouge.

3 - Connecter les bornes des prises (45), (46) à la borne FlexPDU.

Ces prises sont de couleur rouge dans la version du module.

4 - Verrouiller les bornes métalliques des prises.

2.7 Raccordements avec un module HotSwap MBP (Option)

Le rôle du module **HotSwap MBP** est de permettre la maintenance et éventuellement le rechargement de l'alimentation électrique des équipements connectés (fonction **HotSwap**).

Modèle RT

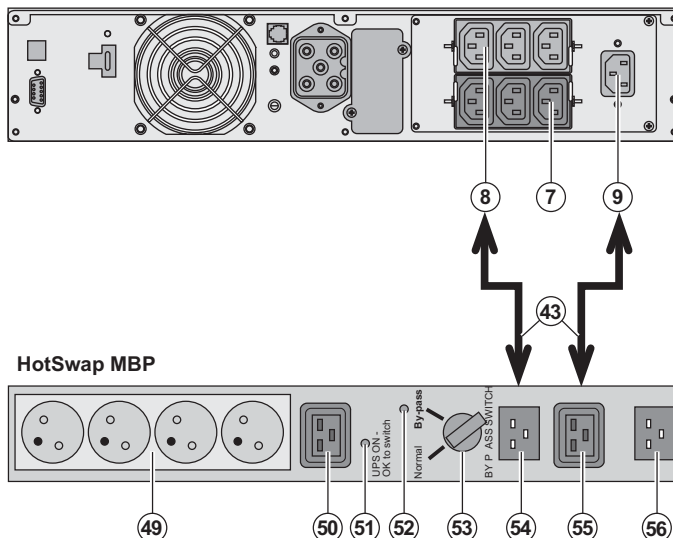

1 - Relier la prise réseau électrique de l'HotSwap MBP à l'aide du cordon (43).

2 - Relier la prise électrique de l'HotSwap MBP à la prise "Input" (55) du module de sortie (prise de sortie) à l'aide du cordon (43). Ces bornes sont de couleur rouge.

3 - Relier une borne (8) à la prise "Input" (55) de l'HotSwap MBP, à l'aide du cordon (43) fourni.

Ce câble et les bornes sont de couleur rouge.

Il est nécessaire d'utiliser un cordon de type 10A FR/DIN du fabricant (réf. 68439) pour le raccordement à l'HotSwap MBP.

Dans le cas d'un module de sortie, le réseau électrique doit être protégé.

2. Installation

Fonctionnement du module HotSwap MBP

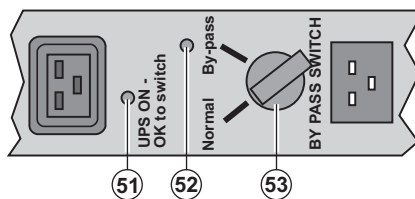

Le module **HotSwap MBP** est un commutateur rotatif (53) qui permet de sélectionner le mode de fonctionnement :
Normal : les équipements sont alimentés par l'ASI.
By-pass : les équipements sont alimentés par le réseau électrique.

Mise en service de l'ASI avec le module HotSwap MBP :

- 1 - Vérifier que l'ASI est raccordée correctement au module **HotSwap MBP**.
 - 2 - Placer le commutateur (53) en position Normal.
 - 3 - Mettre en marche l'ASI en appuyant sur le bouton Marche/Arrêt (27) sur la face avant de l'ASI.
- Les équipements sont alors alimentés par l'ASI.
 Le voyant (51) "UPS ON - OK to switch" s'allume sur le module **HotSwap MBP**.

Test du module HotSwap MBP

- 1 - Placer le commutateur (53) en position By-pass et vérifier que les équipements sont alors toujours alimentés.
- 2 - Remettre le commutateur (53) en position Normal.

2.8 Raccordement d'une ASI dépourvue de module FlexPDU ou HotSwap



Vérifier que les indications portées sur la plaque d'identification située à l'arrière de l'appareil correspondent à la configuration du réseau électrique d'alimentation et à la consommation électrique réelle des équipements.

Modèle Tour

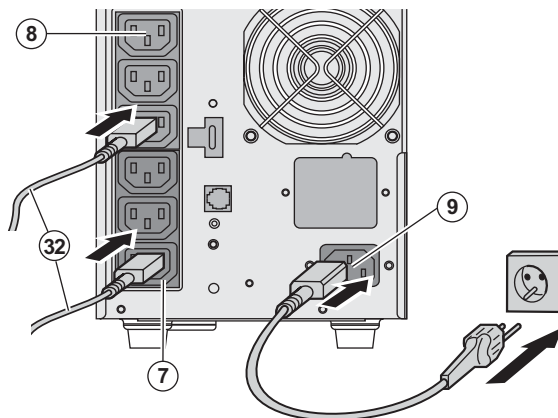

- 1 - Relier la prise d'entrée du serveur au réseau électrique à l'aide du cordon d'alimentation de l'équipement et protéger.
 - 2 - Raccorder les équipements à l'aide des cordons (32).
- Connecter de préférence les équipements prioritaires sur les 3 prises (7) programmables.



Pour commander ou programmer les prises, utiliser l'un des logiciels d'énergie EATON.

Modèle RT

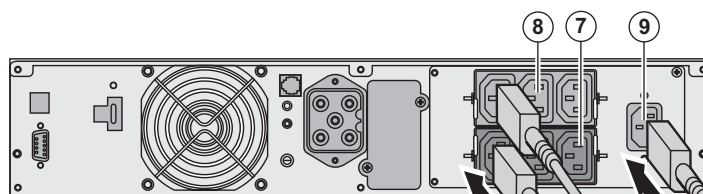



3.1 Mise en service et fonctionnement normal



Lors du premier démarrage, la présence du réseau électrique est indispensable pour déte de câblage. Par la suite, l'appareil pourra démarrer en l'absence du réseau électrique.

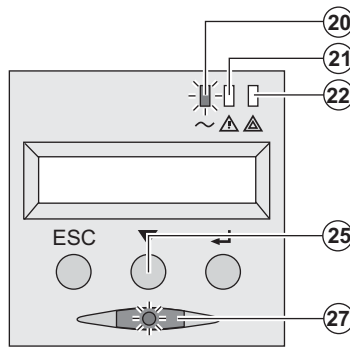

Appuyer sur le bouton (27) environ 1 sec

- Le buzzer émet un bip et tous les voyants
- Le buzzer émet ensuite 2 bips pendant l'au
- reste allumé, signalant l'alimentation des

Les équipements connectés sont protégés

- Le voyant (20) est allumé.
- Si le voyant (22) est allumé, un défaut est
- "Anomalies").
- En mode de fonctionnement normal, le b
- permet de lire les mesures effectuées sur
- électrique, mode de fonctionnement, capa
- numéro de série de l'ASI).



Personnalisation de l'ASI



Si une personnalisation spécifique de l'ASI est envisagée, il est recommandé d'entrer dan personnalisation de l'ASI à cette étape. Ce mode est accessible par les boutons du panneau de commande ou par le logiciel Pers Windows inclus dans le CD-ROM **Solution-Pac** de EATON.

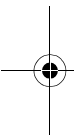

3.2 Fonctionnement sur batterie

Passage sur batterie

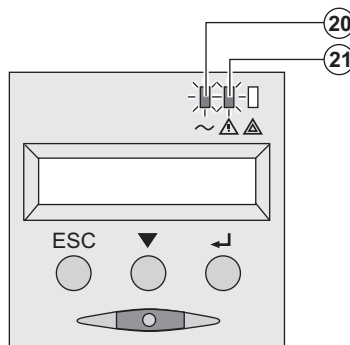

- Les équipements connectés continuent à
- quand le réseau électrique n'est plus disp
- provient de la batterie.
- Les voyants (20) et (21) sont allumés.
- L'alarme sonore émet un bip toutes les 1

Les équipements connectés sont alimentés
L'afficheur indique l'autonomie batterie re

Seuil de préalarme de fin d'autonomie batterie

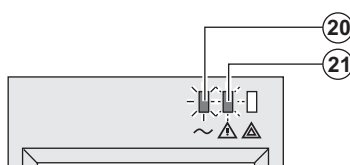

- Les voyants (20) et (21) sont allumés.
- L'alarme sonore émet un bip toutes les 3



3. Utilisation

Fin d'autonomie batterie



- ▶ Tous les voyants sont éteints.
- ▶ L'alarme sonore est silencieuse.



L'ASI est arrêtée complètement.

3.3 Retour du réseau électrique

Après la coupure, l'ASI redémarre automatiquement au retour du réseau électrique (à moins que ce mode ait été désactivée via la personnalisation de l'ASI) et les équipements sont à nouveau alimentés.

3.4 Arrêt de l'ASI

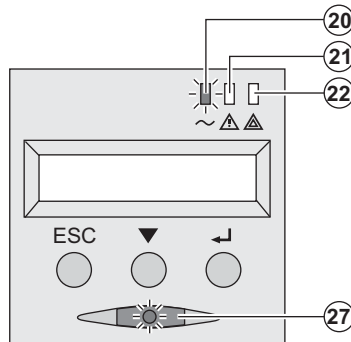

Presser le bouton (27) plus de 2 secondes.

Les équipements connectés à l'ASI ne sont plus alimentés.

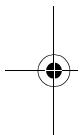

3.5 Utilisation des fonctions de commande à distance de l'ASI

EX dispose au choix de deux dispositifs de commande à distance.

▶ **RPO** : c'est une fonction d'arrêt à distance de l'ASI (**R**emote **P**ower **O**ff) qui permet de mettre hors tension les équipements connectés à l'ASI par un contact utilisateur déporté.

Le redémarrage de l'ASI nécessite une intervention manuelle.

▶ **ROO** : c'est une fonction de marche/arrêt à distance de l'ASI (**R**emote **O**N/**O**FF) qui permet d'avoir l'ASI (27) déportée.

Ces fonctions sont obtenues par l'ouverture du contact que l'on raccorde entre les broches appropriées du connecteur (5) sur la face arrière de l'ASI (voir figures ci-après).



Modèle RT

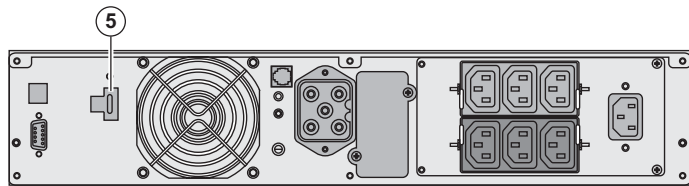

Modèle Tour

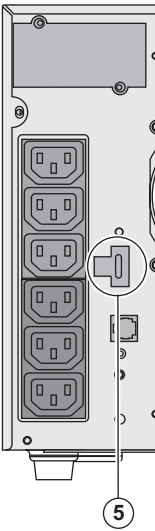

Raccordement et test des commandes à distance



- 1 - Vérifier que l'ASI est en position arrêt et que le réseau électrique d'alimentation est débranché.
- 2 - Oter le connecteur (5) en dévissant les vis.
- 3 - Raccorder un contact sec isolé, de type normalement fermé (60 Vdc / 30 Vac max, 20 mA max, 0,75 mm²) entre les deux broches du connecteur (5), voir figure.

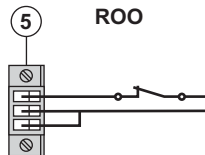

ROO
 Contact ouvert : arrêt de l'ASI
 Contact fermé : mise en marche de l'ASI (ASI raccordée au réseau électrique)
Nota : la commande Marche/Arrêt locale par le bouton (27) reste prioritaire sur la commande à distance.

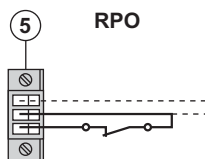

RPO
 Contact ouvert : arrêt de l'ASI
 Pour revenir en fonctionnement normal, désactiver le contact externe et redémarrer l'ASI par le bouton (27).

- 4 - Embrocher le connecteur (5) à son emplacement sur la face arrière de l'ASI.
- 5 - Raccorder et redémarrer l'ASI selon les procédures décrites précédemment.
- 6 - Activer le contact externe d'arrêt à distance pour tester la fonction.



Attention : ce connecteur doit être exclusivement relié à des circuits de niveau TBTS (Très Haute Sécurité).



4. Accès aux mesures et personnalisation

4.1 Synoptique de l'afficheur

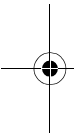
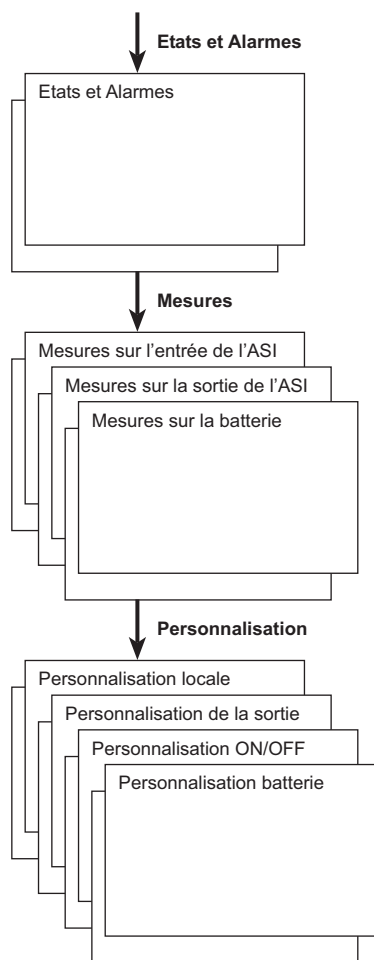

4.2 Accès aux mesures

L'appui successif sur le bouton de défilement (25) permet d'accéder aux états et alarmes éventuels, aux mesures de tension, de courant, de fréquence, de puissance fournie, et d'autonomie batterie.

4.3 Personnalisation par le panneau de commande

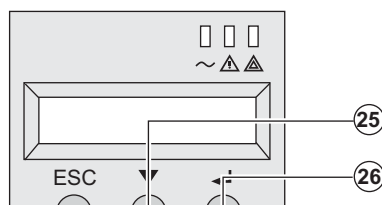

- Presser successivement le bouton de défilement (25) jusqu'à accéder au menu de personnalisation.
- Le bouton de validation (26) permet d'accéder au menu de personnalisation.
- Enfin, confirmer votre choix en pressant à nouveau le bouton de validation (26).



4. Accès aux mesures et pers

Personnalisation de la sortie

| Fonction | Personnalisation usine | Autres choix | Comme |
|---|---|---|--|
| Tension de sortie ⁽¹⁾ | 230 Volts AC | 200/208/220/240/250 Volts AC | |
| Convertisseur de fréquence ⁽¹⁾ | Inactive | Active | Les équip sont jam |
| Fréquence de sortie ⁽¹⁾ | Sélection automatique | 50/60 Hz | Sélectio uniquem convertis active |
| Transfert sur réseau électrique AC By-pass ⁽¹⁾ | Si le réseau électrique AC By-pass est en tolérance | Si le réseau électrique AC By-pass est hors tolérance | |
| Niveau de surcharge ⁽¹⁾ | 100% | 30 / 50 / 70% | Alarme e de seuil |

(1) Ces paramètres ne sont modifiables que si l'ASI est en position OFF.
Les commentaires détaillés sont disponibles dans le logiciel **Personal Solution-Pac**.

Personnalisation Marche/Arrêt (ON/OFF)

| Fonction | Personnalisation usine | Autres choix | Commen |
|--|------------------------|--------------|---|
| Démarrage sur batterie | Active | Inactive | |
| Redémarrage automatique | Active | Inactive | Redémarr au retour |
| Economie d'énergie | Inactive | Active | Si fonction automatiq batterie s de puissa |
| Détection d'inversion phase/neutre (SWF) | Inactive | Active | Si fonction en positio d'inversio |

Personnalisation batterie

| Fonction | Personnalisation usine | Autres choix | Commen |
|--|---|------------------------------------|---------------------------|
| Test de la batterie | Chaque semaine | Pas de test / journalier / mensuel | |
| Préalarme fin d'autonomie | 20% | 0 à 100% | Résolutio |
| Choix des autonomies batterie | Détection automatique du nombre de modules batterie | De 13 à 200 Ah | |
| Protection de la batterie contre les décharges profondes | Active | Inactive | Si fonction de la gara |

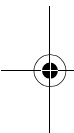



5. Maintenance

5.1 Anomalies



Si le voyant (21) ou (22) est allumé, il y a une anomalie de fonctionnement ou une alarme. Utiliser le bouton d'abandon (24) pour arrêter l'alarme sonore.

| | Symptôme | Diagnostic | Remède |
|---|---|---|---|
| 1 | L'ASI ne démarre pas, l'afficheur alphanumérique indique : COLD START NOK CHECK AC WIRING | Le réseau électrique est absent ou raccordé à la sortie de l'ASI. | Vérifier que l'ASI est correctement au réseau. |
| 2 | Le voyant (22) est allumé, et le voyant SWF (11) est allumé sur la face arrière de l'ASI. L'afficheur alphanumérique indique : INV PHASE/NEUTR CONTROLLER CONNEX | Inversion de phase du réseau d'alimentation. L'ASI reste à l'arrêt. | ► Pour les réseaux de type neutre à la terre : vérifier le câblage : débrancher la prise réseau de l'ASI (SCHUKO), ou faire appel à un électricien pour modifier le raccordement. ► Pour tout autre type de réseau : désactiver la détection de phase. |
| 3 | Le voyant (22) est allumé, l'afficheur alphanumérique indique : PAS DE BATTERIE CONTROLLER CONNEX | La batterie est mal raccordée. | Vérifier le raccordement de la batterie (voir §5.2) et le module batterie. |
| 4 | Le voyant (22) est allumé, l'afficheur alphanumérique indique : DEFAULT BATTERIE CONTACTER SAV | Un défaut a été constaté sur la batterie. | Procéder au remplacement de la batterie (voir §5.2) et le module batterie. Faire appel au service SAV. |
| 5 | Le voyant (21) est allumé, l'afficheur alphanumérique indique : ALARME SURCHARGE REDUIRE CHARGE | Le taux de charge dépasse le niveau de surcharge paramétré, ou dépasse la capacité de l'ASI. | Vérifier la puissance des équipements raccordés et déconnecter les équipements non prioritaires. Vérifier le niveau de surcharge paramétré. |
| 6 | Le voyant (22) est allumé, l'afficheur alphanumérique indique : NON PROTEGE SURCHARGE SORTIE | L'ASI est en surcharge. Les équipements raccordés sont directement alimentés par le réseau électrique via le By-pass. | Vérifier la puissance des équipements raccordés et déconnecter les équipements non prioritaires. |
| 7 | Le voyant (22) est allumé, l'afficheur alphanumérique indique : REDUIRE CHARGE REDEMARRER ASI | Suite à des surcharges répétitives, l'ASI est bloquée en position By-pass. Les équipements raccordés sont directement alimentés par le réseau électrique. | Vérifier la puissance des équipements raccordés et déconnecter les équipements non prioritaires. Arrêter et redémarrer l'ASI pour revenir au fonctionnement normal. |
| 8 | Le voyant (22) est allumé, l'afficheur alphanumérique indique : DEFAULT SURCHARGE REDUIRE CHARGE | L'ASI s'est arrêtée automatiquement pour cause de surcharge importante. | Vérifier la puissance des équipements raccordés et déconnecter les équipements non prioritaires. |
| 9 | Le voyant (22) est allumé, l'afficheur alphanumérique indique : COUR-CIRC CHARGE CONTROLLER CONNEX | L'ASI s'est arrêtée automatiquement pour cause de court-circuit en sortie de l'ASI. | Vérifier l'installation de l'ASI (câblage, équipement) et le module batterie. |

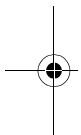



Anomalies sur une ASI équipée d'un module HotSwap MBP



| | Symptôme | Diagnostic | Remède |
|----|---|---|---|
| 12 | Les équipements raccordés ne sont pas alimentés lorsque le commutateur rotatif (49) du module HotSwap MBP est en position By-pass. | <ul style="list-style-type: none"> Les équipements sont raccordés en sortie de l'ASI au lieu d'être raccordés sur le module HotSwap MBP. Le cordon du réseau électrique d'alimentation est raccordé en entrée de l'ASI au lieu d'être raccordé sur le module HotSwap MBP. | Vérifier l'installation et le module (§2.6). |
| 13 | Les équipements raccordés ne sont pas alimentés lorsque le commutateur rotatif (49) du module HotSwap MBP est en position Normal. | <ul style="list-style-type: none"> L'ASI est à l'arrêt. Le câblage n'est pas conforme entre l'ASI et le module HotSwap MBP. | <ul style="list-style-type: none"> Démarrer l'ASI. Vérifier le câblage du module. |
| 14 | Les équipements raccordés ne sont pas alimentés en cas de coupure du réseau électrique. | <ul style="list-style-type: none"> Le commutateur rotatif (49) du module HotSwap MBP est en position By-pass. Le câblage n'est pas conforme entre l'ASI et le module HotSwap MBP. | <ul style="list-style-type: none"> Mettre le commutateur en position Normal. Vérifier le câblage du module. |

En cas de défaut entraînant l'arrêt de l'ASI, appuyer sur le bouton Marche/Arrêt (27) pour redémarrer l'ASI.

5.2 Remplacement du module batterie

Rappel sur les consignes de sécurité :



La batterie présente un risque d'électrocution et un courant de court-circuit élevé. Les précautions doivent être prises pour toute intervention sur les éléments batterie :

- Porter des mains montres, bagues, alliances, bracelets ou tout autre objet métallique, et éviter de toucher les composants internes.
- Utiliser des outils dont le manche est isolé.

Démontage du module batterie

Modèle RT

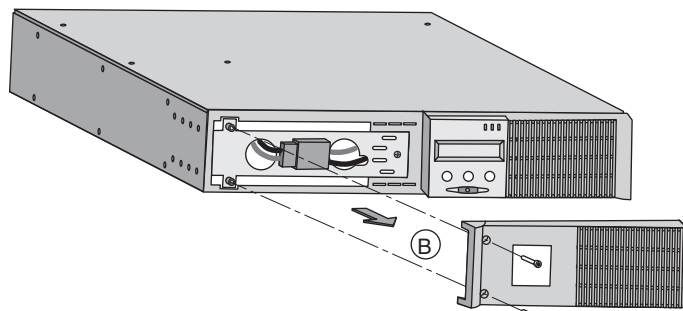

- A - Dévisser la batterie avant fixée par le module.
- B - Retirer cette batterie du module.



5. Maintenance

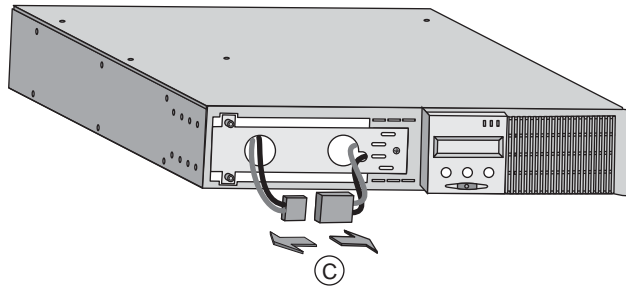

C - Débrancher le bloc batterie des 2 connecteurs (ne jeter les câbles).

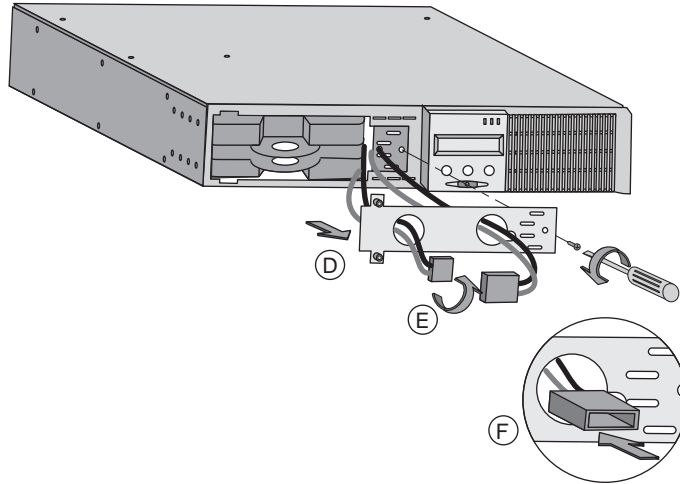

D - Enlever le capot métallique de protection batterie fixé par vis.
E - Faire pivoter le connecteur.
F - Passer le connecteur à travers le capot.

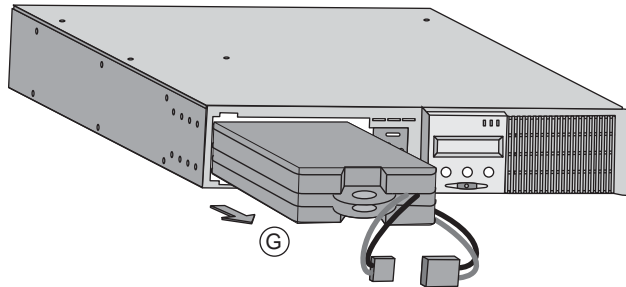
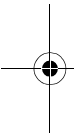

G - Extraire le bloc batterie du boîtier en soulevant la languette plastique et presser sur le bouton de remplacement.

Modèle Tour



A - Déposer la face avant du boîtier à côté de l'ASI.



5.

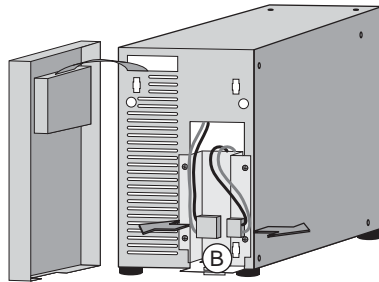

B - Débrancher les 2 connecteurs (câbles).

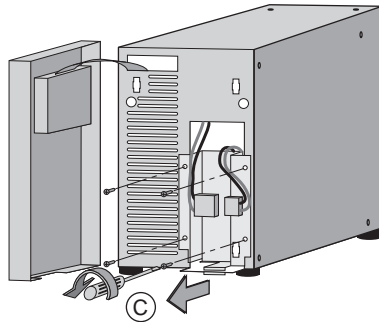

C - Déposer le couvercle métallique de protection.

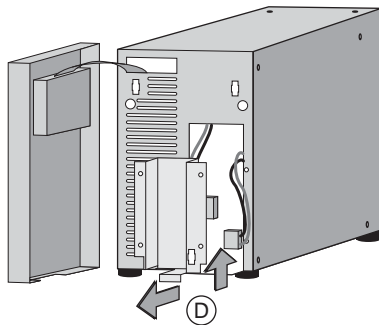

D - Enlever le module batterie.

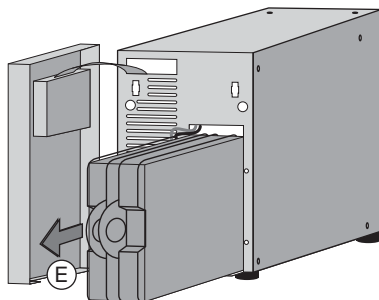

E - Extraire le bouchon de la languette plastique pour le remplacement.

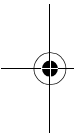



5. Maintenance

5.3 Maintenance d'une ASI équipée d'un module HotSwap MBP

Modèle RT

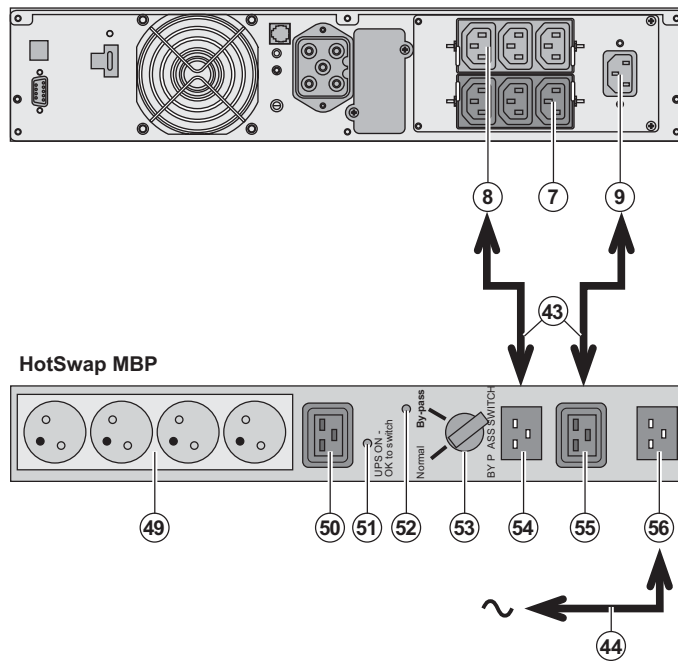

Le rôle du module **HotSwap MBP** est de permettre la maintenance éventuellement le remplacement des équipements connectés (sans affecter l'alimentation des équipements connectés au HotSwap).

Maintenance :

1 - Placer le commutateur By-pass : le voyant rouge **HotSwap MBP** s'allume et les équipements sont alimentés directement par le réseau.
2 - Arrêter l'ASI en appuyant sur le bouton Marche/Arrêt (27) sur la face avant de l'ASI : le voyant (51) "UPS OK to switch" s'éteint, l'ASI se déconnecte et remplace le module HotSwap MBP.

Retour en fonctionnement :

1 - Vérifier que l'ASI est correctement connecté au module HotSwap MBP.
2 - Mettre en marche l'ASI en appuyant sur le bouton Marche/Arrêt (27) sur la face avant de l'ASI : le voyant (51) "UPS OK to switch" s'allume et le module HotSwap MBP se reconnecte avec l'ASI.

3 - Mettre le commutateur Normal : le voyant rouge **HotSwap MBP** s'éteint.

4 - Les équipements sont protégés par l'ASI.

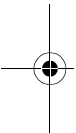



5.4 Centre de formation



Pour maîtriser l'exploitation de votre appareil EATON et intervenir au premier niveau, nous avons à votre disposition un programme complet de formations techniques en langues anglaise.

Pour plus d'informations, consulter notre site internet : www.eaton.com

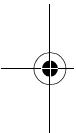



6. Annexes

6.1 Spécifications techniques

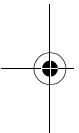
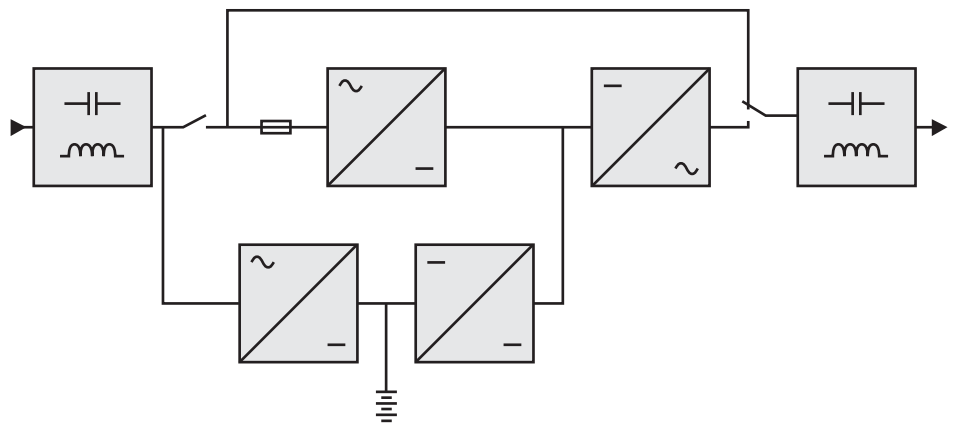

| | EX 700 | EX 1000 EX 1000 RT | EX 1500 EX 1500 RT |
|---|---|---|---|
| Puissance de sortie | 700 VA / 630 W | 1000 VA / 900 W ⁽³⁾ | 1500 VA / 1350 W ⁽⁴⁾ |
| Réseau électrique d'alimentation <ul style="list-style-type: none"> ▶ Tension ▶ Fréquence ▶ Facteur de puissance | Monophasée 100 / 120 / 140 / 160 à 284 V ⁽⁵⁾ 50/60 Hz (auto-sélection) > 0,95 | | |
| Sortie utilisation <ul style="list-style-type: none"> ▶ Tension ▶ Fréquence ▶ Distorsion harmonique (THDV) ▶ Capacité de surcharge | Monophasée 230 V ±3% ⁽⁶⁾ 50/60 Hz ±0,5% ⁽⁷⁾ < 4% sur charge linéaire, < 6% sur charge non linéaire 102% permanent, 130% 12 s, > 130% 2 s | | |
| ▶ Courant | 3 A ⁽⁸⁾ | 4,3 A ⁽⁸⁾ | 6,5 A ⁽⁸⁾ |
| Batterie | 2x12 V - 7 Ah, au plomb, étanche, sans entretien | 3x12 V - 7 Ah, au plomb, étanche, sans entretien | 3x12 V - 9 Ah, au plomb, étanche, sans entretien |
| Environnement <ul style="list-style-type: none"> ▶ Niveau de bruit ▶ Température de fonctionnement ▶ Humidité ▶ Courant de fuite ▶ Température de stockage ▶ Altitude | < 38 dBA 0°C à 40°C 20% à 90% (sans condensation) < 1,1 mA -25°C à 40°C 1000 m | | |
| Normes et certification <ul style="list-style-type: none"> ▶ Sécurité ▶ Performance | IEC/EN 62040-1-1, EN 60950-1 (RD) IEC/EN 62040-3 EN 50091-2/IEC 60910-2-1, EN 50091-2/IEC 61000-1-2/3/4/5/6/11 | | |



6.2 Glossaire

| | |
|---|--|
| AC By-pass | Voie dérivée du réseau électrique d'alimentation, commandée par le logiciel de protection des équipements, permettant une alimentation directe des équipements par le réseau électrique en cas de dysfonctionnement de l'onduleur. |
| AC Normal | Il s'agit du réseau électrique d'alimentation normal de l'ASI. |
| ASI | Alimentation Sans Interruption. |
| Autonomie | Temps pendant lequel les équipements sont alimentés par l'ASI. |
| Convertisseur de fréquence | Fonction permettant de convertir la fréquence du réseau électrique d'entrée en sortie de l'ASI (50 Hz -> 60 Hz ou 60 Hz -> 50 Hz). |
| Décharge profonde | Décharge de la batterie au delà de la limite permise occasionnant des dommages irréversibles sur la batterie. |
| Démarrage sur batterie | Permet la mise sous tension des équipements connectés à l'ASI en cas de panne du réseau électrique d'alimentation. L'ASI fonctionne alors sur batterie un certain temps. |
| Equipements | Appareils ou dispositifs raccordés en sortie de l'ASI. |
| FlexPDU | Module de prises de sortie ASI pour installation dans une baie. Il existe différents types de modules correspondant à différents besoins. |
| HotSwap MBP | Module de dérivation manuelle de l'ASI en vue d'une maintenance sans interruption. Il existe différents types de modules correspondant à différents besoins. |
| Marche/Arrêt onduleur par logiciel | Permet d'autoriser ou d'interdire au logiciel de protection des équipements le déclenchement de séquences Marche/Arrêt de l'ASI. |
| Personnalisation | Programmation de certains paramètres différente de la configuration d'usine. Certaines fonctions de l'ASI peuvent être modifiées par le logiciel de protection des équipements Pac afin de mieux satisfaire vos besoins. |
| Prises programmables | Prises pouvant être délestées automatiquement pendant l'autonomie de l'ASI (temporisation d'ouverture programmable par le logiciel de protection des équipements). L'ASI comporte deux groupes de deux prises programmables. |
| Seuil de préalarme de fin d'autonomie batterie | Il s'agit d'un seuil du niveau de tension batterie permettant de déclencher un préalarme de fin d'autonomie batterie et prendre alors les dispositions imposées par le logiciel de protection des équipements sur les équipements. |
| Taux de charge | Rapport de la puissance consommée par les équipements connectés à l'ASI sur la puissance maximale que peut fournir l'ASI. |
| Test de la batterie | Test interne à l'ASI permettant de vérifier l'état de la batterie. |

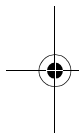

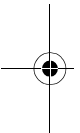



www.eaton.com

EX
700 - 1000
1000 RT -
EXB 1000
EXB 1000

Installatio
Bedienun

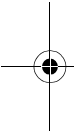

Pulsar Series

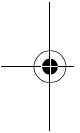



Wir danken Ihnen, dass Sie sich für ein Produkt von EATON zum Schutz Ihrer Anwendung entschieden haben.

Die Baureihe **EX** wurde mit größter Sorgfalt entwickelt.

Um die Leistungen Ihrer **USV (Unterbrechungsfreien Stromversorgung)** optimal nutzen zu können, bitten wir Sie, sich ein wenig Zeit zu nehmen und die vorliegende Anleitung aufmerksam zu lesen.

Vor der Installation von **EX** sollten Sie sich mit den geltenden Sicherheitsvorschriften vertraut machen und anschließend die Hinweise der vorliegenden Anleitung befolgen.

Entdecken Sie das umfassende Angebot von EATON sowie weitere Optionen zur Baureihe **EX** auf www.eaton.com bzw. www.eaton.com, oder wenden Sie sich persönlich an den Vertreter Ihrer Region.

Umweltfreundlichkeit

Für EATON sind der Schutz und die Erhaltung der Umwelt wichtige Unternehmensziele. Alle unsere Produkte werden im Hinblick auf ihre Umweltverträglichkeit entwickelt.

Schadstoffe

Dieses Produkt enthält weder FKW- oder FCKW-Verbindungen noch Asbest.

Verpackung

Zur umweltgerechten Entsorgung und Wiederaufbereitung sollten die Verpackungsmaterialien nach den örtlichen Vorschriften sortiert werden.

► Die verwendeten Kartonnagen bestehen zu 50% aus Recyclingpappe.

► Sämtliche Beutel bestehen aus Polyethylen.

► Alle verwendeten Materialien sind wiederverwertbar und mit dem Symbol  gekennzeichnet.

| Material | Kurzbezeichnung | Kennziffer im Symbol |
|------------------------------|-----------------|----------------------|
| Polyethylenterephthalat | PET | 01 |
| Polyethylen hoher Dichte | HDPE | 02 |
| Polyvinylchlorid | PVC | 03 |
| Polyethylen niedriger Dichte | LDPE | 04 |
| Polypropylen | PP | 05 |
| Polystyrol | PS | 06 |

Verpackungsmaterial muss gemäß den gesetzlichen Bestimmungen entsorgt werden.

Recycling der USV nach Ablauf der Lebensdauer

EATON verpflichtet sich, sämtliche nach Ablauf der Lebensdauer rückgeführten Komponenten der Wiederverwertung gemäß den gesetzlichen Bestimmungen zuzuführen (wenden Sie sich an die lokale EATON-Vertretung).

Zu diesem Zweck arbeitet EATON mit zugelassenen Entsorgungsunternehmen zusammen.

Produkt

Das Produkt besteht aus wiederverwertbaren Materialien.

Ihre Entsorgung muss gemäß den geltenden gesetzlichen Bestimmungen erfolgen.

Nach Ablauf der Lebensdauer muss das Produkt in einer zugelassenen Annahmestelle für Altgeräte abgegeben werden.

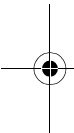



Allgemeines

Bedeutung der Piktogramme



Unbedingt zu befolgende Hinweise.



Informationen, Ratschläge, Hilfen.



Optische Anzeige.



Maßnahmen, Handlungen.



Akustischer Alarm.

In den Abbildungen der nachfolgenden Seiten sind die LED-Anzeigen mit folgenden Symbolen dargestellt.



LED AUS



LED AN



LED blinkt

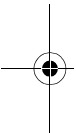



1. Ansichten und Beschreibung

1.1 Aufstellvarianten

Tower-Modell.....

Rack-Modell

1.2 Rückansicht

EX 700 / 1000 / 1500.....

EX 1000 RT / 1500 RT

EX EXB (Batterie-Erweiterungsmodul)

EX EXB RT (Batterie-Erweiterungsmodul).....

1.3 Bedien- und Anzeigefeld

2. Aufstellung und Installation

2.1 Entfernen der Verpackung und Überprüfung des Lieferumfangs

2.2 Installation des Modells RT in Tower-Aufstellung

2.3 Installation des Modells RT in einem Rack

2.4 Kommunikationsschnittstellen

Anschluss der RS232- bzw. der USB-Schnittstelle (wahlweise).....

Einbau der optionalen Kommunikationskarten.....

2.5 Anschlussbelegung der optionalen kommunikationskarte

2.6 USV-Anschluss mit optionalem FlexPDU-Installationsverteiler (Power

2.7 USV-Anschluss mit optionalem HotSwap MBP-Modul

Funktionsweise des HotSwap MBP-Moduls.....

2.8 USV-Anschluss ohne FlexPDU- oder HotSwap MBP-Modul

3. Betriebszustände

3.1 Inbetriebnahme und Normalbetrieb

3.2 Batteriebetrieb

3.3 Rückkehr der Netzspannung

3.4 Abschaltung der USV

3.5 Verwendung der Fernbetätigungsfunktionen der USV

4. Kundenspezifische Anpassung und Abfrage der Messwerte

4.1 Darstellungsmöglichkeiten des Displays

4.2 Abfrage der Messwerte

4.3 Kundenspezifische Anpassung über Bedienfeld

4.4 Kundenspezifische Anpassung über externe Software

5. Wartung und Service

5.1 Betriebsstörungen

Betriebsstörungen bei einer USV mit HotSwap MBP-Modul.....

5.2 Austausch des Batteriemoduls

Sicherheitshinweise

Ausbau des Batteriemoduls

Einbau des neuen Batteriemoduls

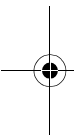



1. Ansichten und Beschreibung

1.1 Aufstellvarianten

Tower-Modell

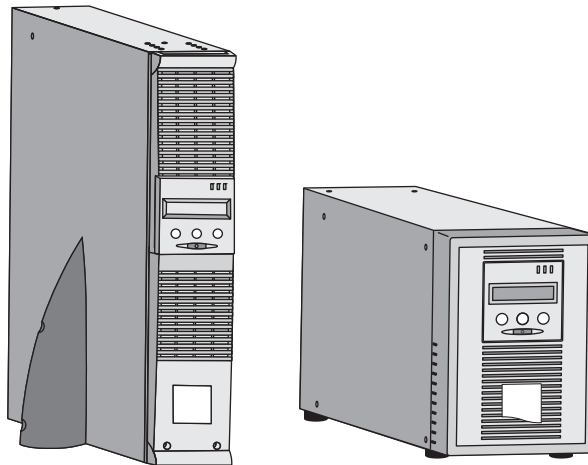

| Abmessungen (H x B x T) in mm | |
|----------------------------------|---|
| EX 700 | 2 |
| EX 1000 | 2 |
| EX 1000 RT | 8 |
| EX 1500 | 2 |
| EX 1500 RT | 8 |
| EX EXB | 2 |
| EX EXB RT | 8 |

| Gewicht in kg | |
|---------------|---|
| EX 700 | 1 |
| EX 1000 | 1 |
| EX 1000 RT | 1 |
| EX 1500 | 1 |
| EX 1500 RT | 2 |
| EX EXB | 2 |
| EX EXB RT | 2 |

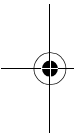

Rack-Modell

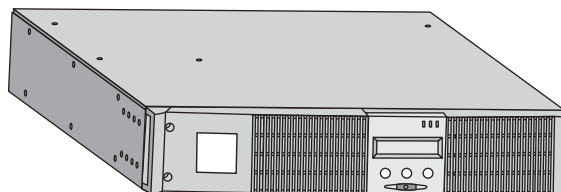



1. Ansichten und

1.2 Rückansicht

EX 700 / 1000 / 1500

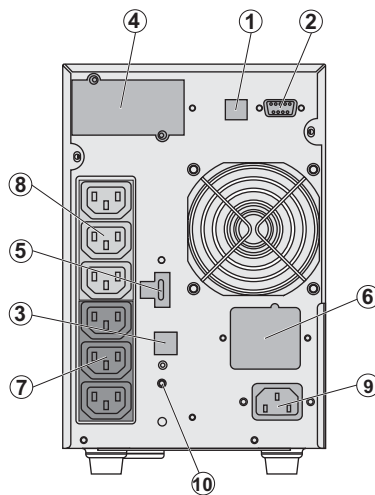

- (1) USB-Schnitt
 - (2) Kommunika
 - (3) Stecker zur a
 - (4) Steckplatz fü
 - (5) Steckverbin
 - (6) Steckverbin
 - (7) 3 programm
 - (8) 3 programm
 - (9) Netzanschl
 - (10) LED-Anzeig
- korrekten Netza
(SWF)

EX 1000 RT / 1500 RT

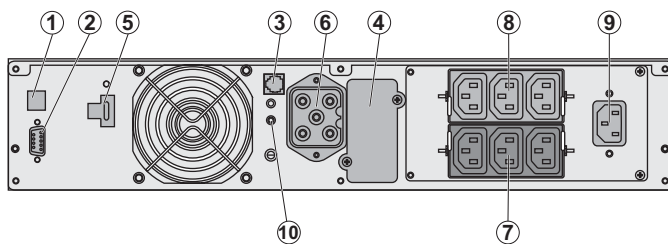

EX EXB (Batterie-Erweiterungsmodul)

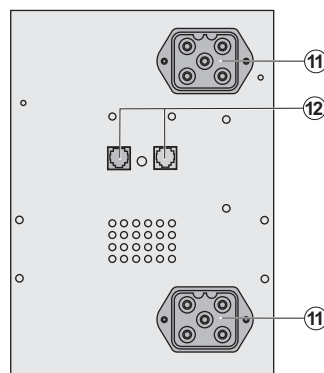

- (11) Steckverbin
 - (12) Stecker zur
- des externen Ba



1. Ansichten und Beschreibung

EX EXB RT (Batterie-Erweiterungsmodul)

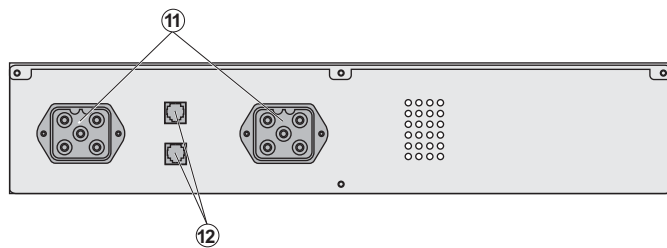

1.3 Bedien- und Anzeigefeld

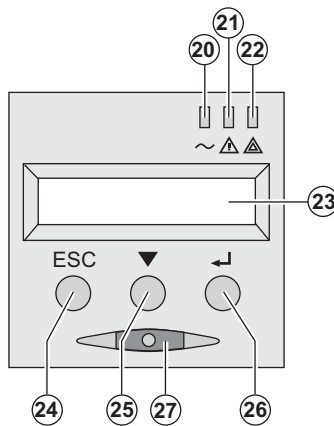

- (20) LED "Verbraucher g
- (21) LED "Störbetrieb"
- (22) LED "Verbraucher ni
- (23) Alphanumerisches D
- (24) Taste Funktionsabbr
- zum vorherigen Menüpu
- (25) Scroll-Taste
- (26) Bestätigungstaste
- (27) EIN/AUS-Taste für L
- Ausgangsteckdosen

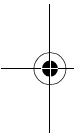



2. Aufstellung und

2.1 Entfernen der Verpackung und Überprüfung des Lieferumfangs

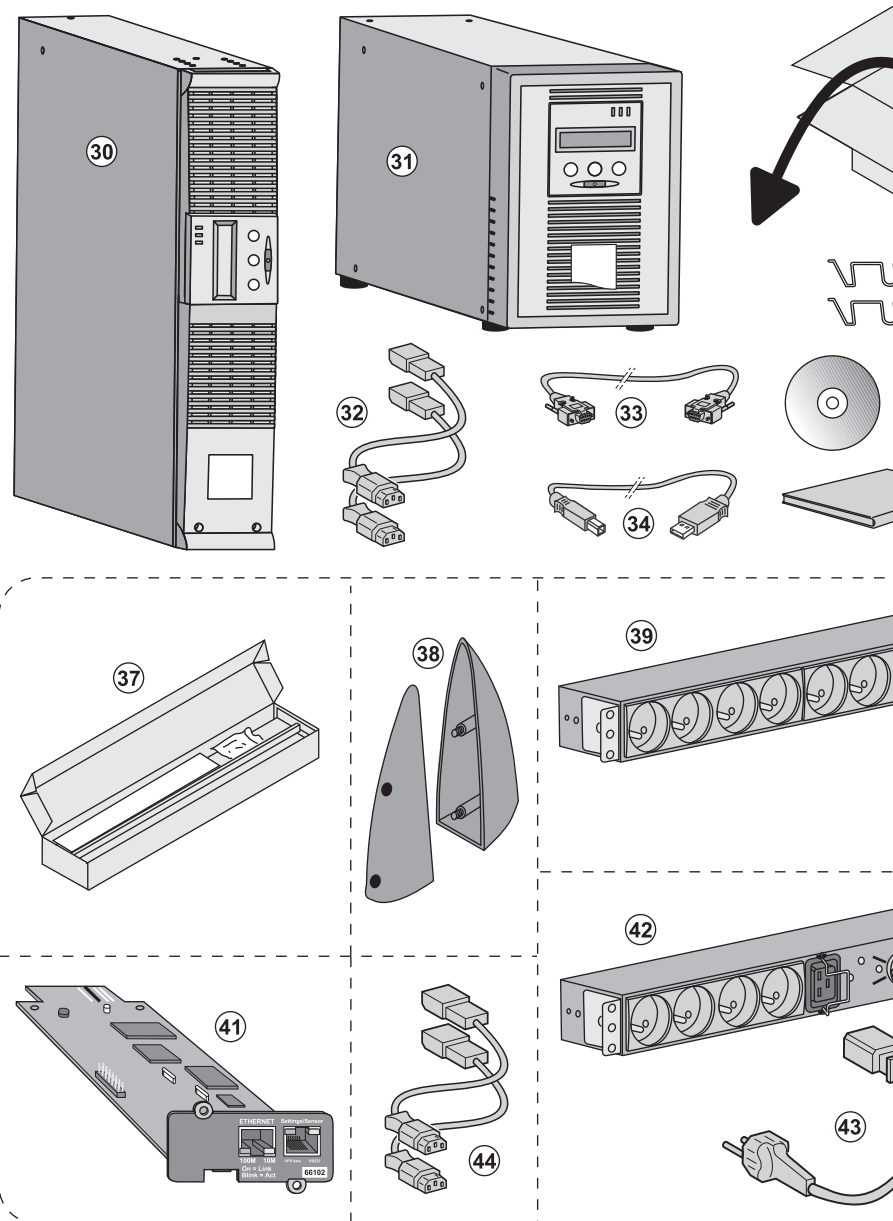

(30) EX 700, 1000, 1500.

(31) EX 1000 RT, 1500 RT.

(32) 2 Verbraucher-Anschlusskabel.

(33) RS232-Kabel.

(34) USB-Kabel.

(35) Verriegelungsabdeckung für Verbraucher-

Lieferbestandteile je nach Vers

(37) Montagekit für Einbau in 19

(38) 2 Stützfüße für Toweraufst

(39) FlexPDU-Modul (Option).

(40) Verbindungskabel FlexPDU

(41) NMC-Kommunikationskart



2. Aufstellung und Installation

2.2 Installation des Modells RT in Tower-Aufstellung

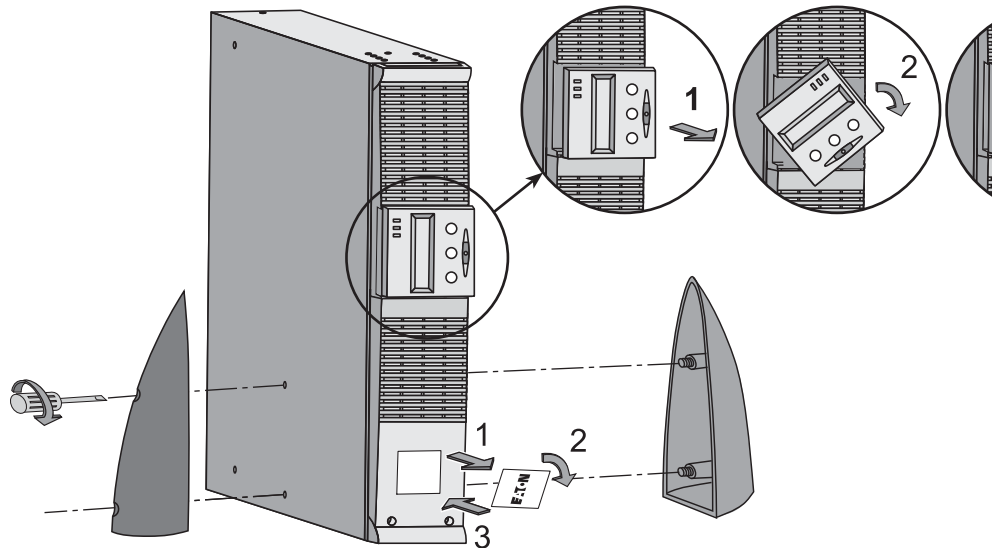

2.3 Installation des Modells RT in einem Rack

Es wird empfohlen, das oder die EXB-Batteriemodul(e) möglichst weit unten im Rack anzubringen und darüber zu installieren.

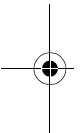

Zur Befestigung des Moduls auf den Teleskopschienen Schritte 1 bis 4 befolgen.

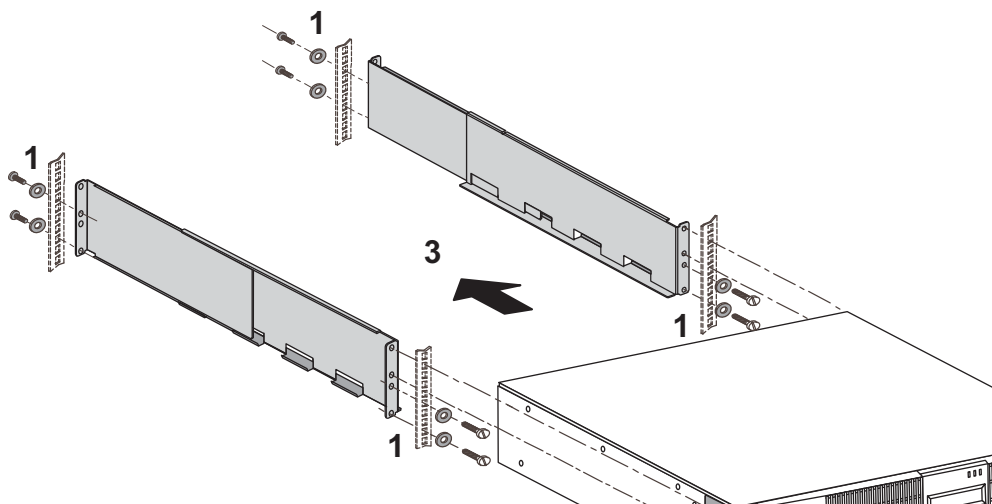



2. Aufstellung und

2.4 Kommunikationsschnittstellen

Anschluss der RS232- bzw. der USB-Schnittstelle (wahlweise)



RS232- und USB-Schnittstelle können nicht gleichzeitig verwendet werden.

Tower-Modell

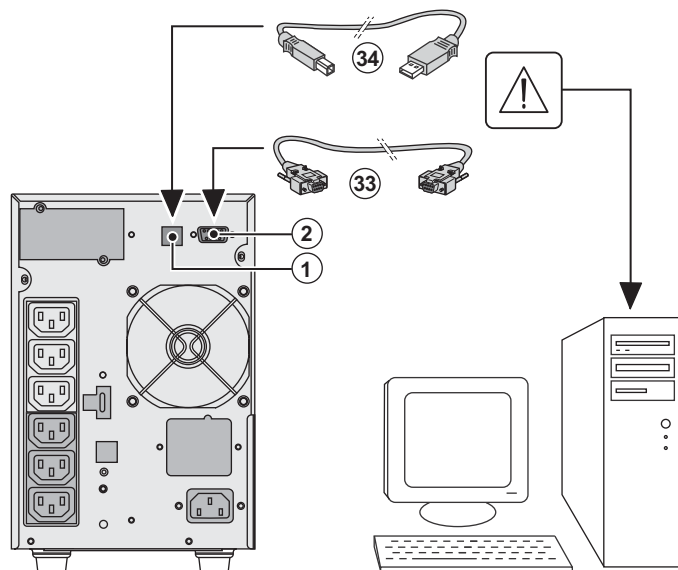

1 - Kabel (33) oder USB-Schnittstelle des Rechner-systems

2 - Das jeweils a (33) oder (34) an bzw. den RS232 anschließen.

Die USV kann n Softwarepakete angeschlossen kommunizieren Konfiguration, S

RT-Modell

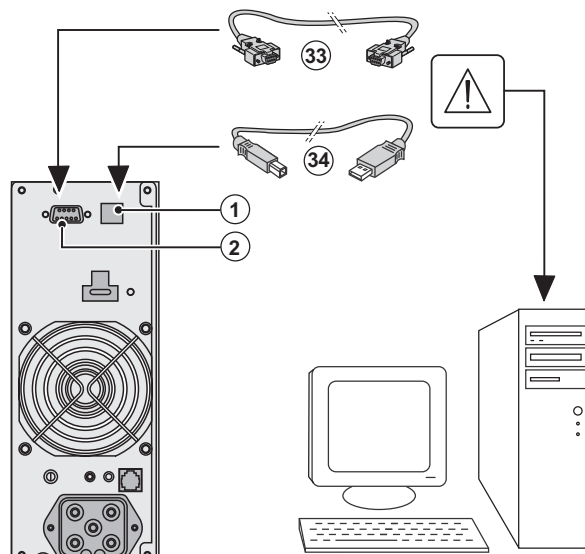



2. Aufstellung und Installation

Einbau der optionalen Kommunikationskarten



Tower-Modell

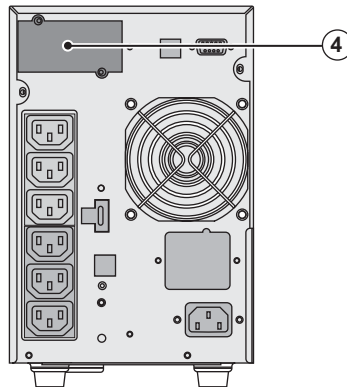

RT-Modell

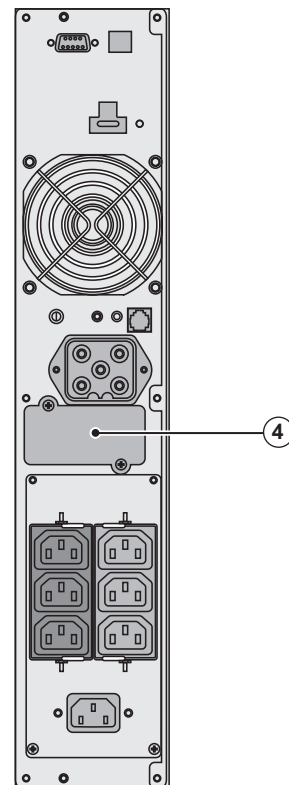

Die Kommunikationskarte wird in den Slot (4) einer eingeschalteten USV installiert (beschränkter Zugang).

- 1 - Kartenfachabdeckung der Rückseite abschrauben und herausnehmen.
- 2 - Kommunikationskarte in den entsprechenden Steckplatz einsetzen.
- 3 - Abdeckung erneut anbringen.

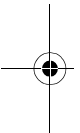

2.5 Anschlussbelegung der optionalen kommunikationskarte (2)

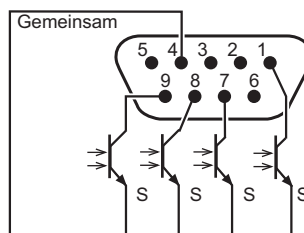

- ▶ Pin 2, 3, 5 und 6 : unbenutzt.
- ▶ Pin 1 : NRE-Betrieb.
- ▶ Pin 4 : gemeinsamer Rückleiter.
- ▶ Pin 7 : Voralarm "Ende der Autonomiezeit".
- ▶ Pin 8 : Verbraucher geschützt.
- ▶ Pin 9 : Batteriebetrieb.

S : Schließer.

Bei aktivem Signalzustand ist der Kontakt zwischen dem entsprechenden Pin und dem gemeinsamen Leiter geschlossen.

Kennwerte der Kontakte (Optokoppler)

- ▶ Spannung : max. 48 V DC,
- ▶ Strom : max. 25 mA,
- ▶ Leistung : 1,2 W.



2. Aufstellung und

2.6 USV-Anschluss mit optionalem FlexPDU-Installationsverteiler (Power Distribution Unit)

RT-Modell

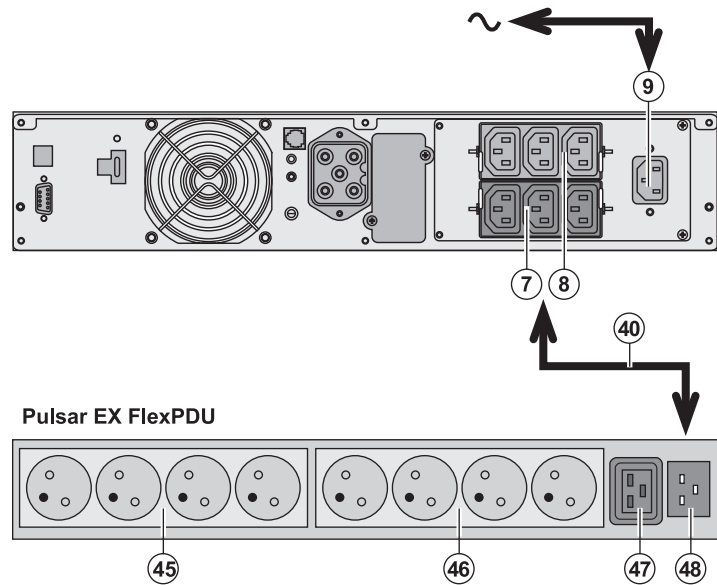

1 - Eingangssteckdose dem Netzkabel des Verbrauchers anschließen.

2 - Eingangssteckdose des Moduls über das IEC 10A/16A mit dem (7) oder (8) der RT-Modell und die gekennzeichnete Steckdose (40) anschließen.

3 - Verbraucher (46) und (47) des Moduls anschließen. Die Verbraucher sind je nach Ausführung unterschiedlich.

4 - Kabel mit Hi... Steckdosenabbl...

2.7 USV-Anschluss mit optionalem HotSwap MBP-Modul

Das **HotSwap MBP**-Modul ermöglicht die Wartung und ggf. den Austausch der USV, ohne die angeschlossenen Verbraucher unterbrechen zu müssen (**HotSwap**-Funktion).

RT Modell

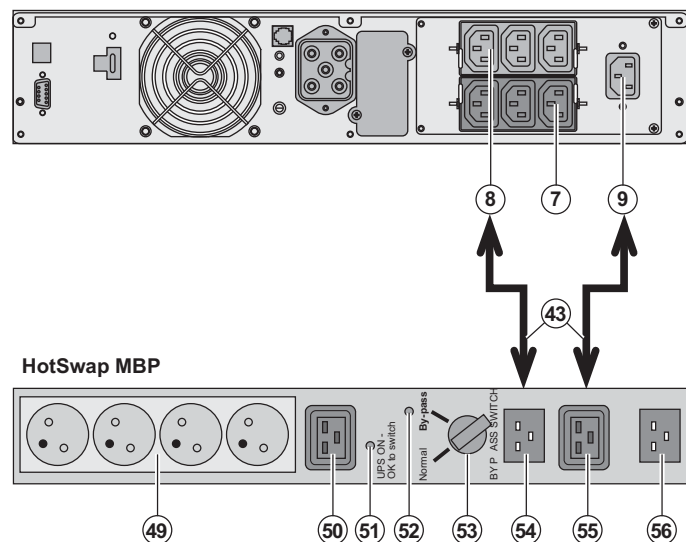

1 - Eingangssteckdose des **HotSwap MBP**-Moduls über das Netzkabel (44) mit dem RT-Modell verbinden.

2 - Eingangssteckdose des Moduls über das mitgelieferte Netzkabel (43) mit der Steckdose "UPS" des **HotSwap MBP**-Moduls verbinden. Die anderen Steckdosen sind für die Verbraucher.

3 - Ausgangssteckdosen des Moduls über das mitgelieferte Netzkabel (43) mit den Steckdosen "UPS" des **HotSwap MBP**-Moduls verbinden.

Für die Spannungswahl des Moduls (R) der Kabelsatz 10... **HotSwap MBP** Moduls (R) Bei einer Spannr...

2. Aufstellung und Installation

Funktionsweise des HotSwap MBP-Moduls

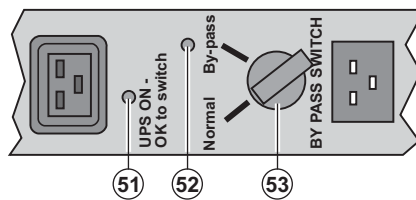

An der Rückseite des HotSwap MBP-Moduls befindet sich ein Drehschalter mit 2 Schaltstellungen:

Stellung Normal:
Die Verbraucherversorgung wird über die USV.

Stellung Bypass:
Die Verbraucherversorgung wird direkt vom Einspeisernetz.

Einschalten der USV bei Verwendung des HotSwap MBP-Moduls:

- 1 - Korrekten Anschluss der USV an das **HotSwap MBP**-Modul überprüfen.
 - 2 - Drehschalter **(53)** in die Stellung "Normal" bringen.
 - 3 - USV durch Betätigung der EIN/AUS-Taste **(27)** an der Frontseite des Geräts einschalten.
- Die Verbraucher werden über die USV versorgt.
Die LED **(51)** "UPS ON - OK to switch" am **HotSwap MBP**-Modul leuchtet auf.

Funktionstest des HotSwap MBP-Moduls.

- 1 - Schalter **(53)** in die Stellung "By-pass" bringen und überprüfen, dass die Verbraucher weiter versorgt werden.
- 2 - Drehschalter **(53)** erneut in die Stellung "Normal" zurückstellen.

2.8 USV-Anschluss ohne FlexPDU- und oder HotSwap MBP-Modul



Kenndaten auf dem Typenschild (siehe Geräte-Rückseite) hinsichtlich Übereinstimmung mit den Netzparametern und der Leistungsaufnahme aller angeschlossenen Verbraucher überprüfen.



Tower-Modell

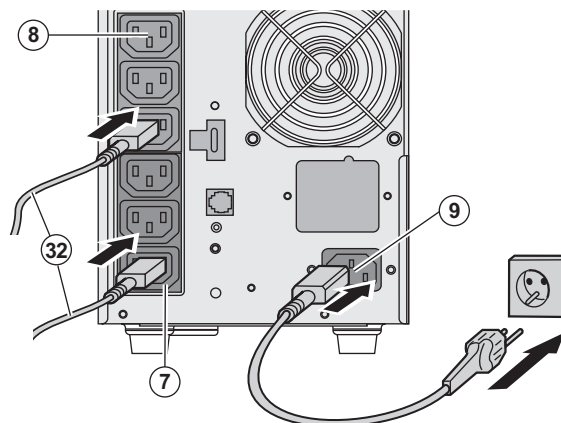

1 - Eingangssteckdose **(9)** mit dem Netzkabel des zu schaltenden Verbrauchers an das Stromversorgungsmodul anschließen.

2 - Verbraucher mit Hilfe des Anschlusskabels **(32)** an das Stromversorgungsmodul anschließen.

3 - Verbraucher mit hoher Leistung vorzugsweise an die 3-Phasen-Steckdosen (weniger wichtige Verbraucher an die 2-Phasen-Steckdosen) paarweise programmieren **(7)** (Gruppe 1/Gruppe 2).

Zur Steuerung oder Programmierung der Steckdosen eine Energiemanagementsoftware verwenden.



RT-Modell

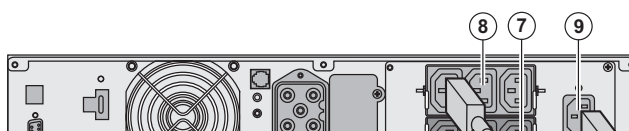



3. Betrieb

3.1 Inbetriebnahme und Normalbetrieb



Bei der erstmaligen Inbetriebnahme muss das elektrische Einspeisnetz vorhanden sein, damit Anschlussfehler erkannt werden können. Anschließend kann die USV auch ohne vorhandenes Netz gestartet werden.

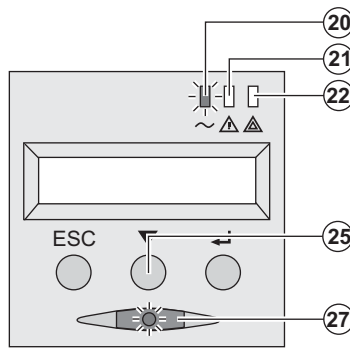

Taste (27) etwa 1 Sekunde lang drücken.
 ► Der Summer ertönt kurz, und sämtliche LEDs (20, 21) leuchten auf.
 ► Während des anschließenden Selbsttests blinkt das Display zweimal. Die LED der Drucktaste (27) leuchtet auf, an, dass die Ausgangssteckdosen versorgt sind.



Die angeschlossenen Verbraucher sind durch den UPS geschützt.
 ► LED (20) leuchtet auf.
 Wenn LED (22) aufleuchtet, liegt eine Störung vor ("Betriebsstörungen").
 ► Im Normalbetrieb können mit der Scroll-Taste die Messwerte und Kenndaten der USV abgerufen werden (Eingangsspannung von Netz 1 [Gleichrichtung], Ausgangsspannung, Betriebsart, Batteriekapazität und Seriennummer).

Kundenspezifische Anpassung der USV



Ist eine kundenspezifische Anpassung der USV vorgesehen, sollte sie in an dieser Stelle durchgeführt werden. Die Anpassung erfolgt über das Bedien- und Anzeigefeld oder über die USV-Software PowerControl Windows, die sich auf der mitgelieferten CD-ROM **Solution-Pac** befindet.

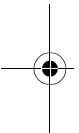

3.2 Batteriebetrieb

Umschaltung auf Batteriebetrieb

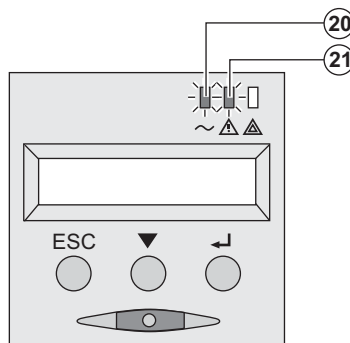

► Bei einem Netzausfall werden die angeschlossenen Verbraucher von der Batterie weiter versorgt.
 ► Die LEDs (20) und (21) leuchten auf.
 ► Der Summer ertönt alle 10 Sekunden.

Die angeschlossenen Verbraucher werden weiterhin versorgt.
Das Display zeigt die verbleibende Autonomiezeit.

Voralarm "Ende der Autonomiezeit"



► Die LEDs (20) und (21) leuchten auf.
 ► Der Summer ertönt alle 3 Sekunden.



3. Betriebszustände

Abschaltung am Ende der Autonomiezeit



- ▶ Alle LEDs sind aus.
- ▶ Der Summer gibt keinen Ton ab.



Die USV ist vollständig abgeschaltet.

3.3 Rückkehr der Netzspannung

Bei Netzurückkehr nach einer Abschaltung erfolgt ein automatischer Neustart der USV, sofern die kundenspezifische Anpassung deaktiviert wurde.

3.4 Abschaltung der USV

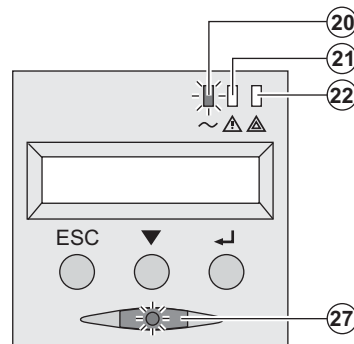

Taste (27) mehr als 2 Sekunden gedrückt halten.

Die an die USV angeschlossenen Systeme werden versorgt.

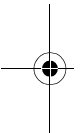

3.5 Verwendung der Fernbetätigungsfunktionen der USV

EX arbeitet wahlweise mit zwei Fernbetätigungsvorrichtungen.

▶ **RPO**: Fernabschaltung der USV (**R**emote **P**ower **O**ff), mit der alle an die USV angeschlossenen Systeme eine dezentrale Betätigung des Anwenders abgeschaltet werden können.

Das erneute Einschalten der USV muss manuell erfolgen.

▶ **ROO**: Fernbedientes Ein-/Ausschalten der USV (**R**emote **O**N/**O**FF). Diese Funktion ermöglicht eine dezentrale Betätigung über die Taste (27).

Diese Funktionen werden durch die Öffnung des Kontakts erhalten, der zwischen dem entsprechenden Steckverbinder (5) an der Rückseite der USV angeschlossen wird (siehe Abbildung unten).



RT-Modell

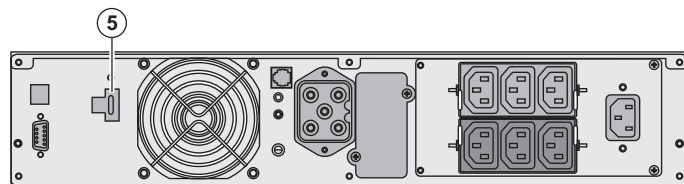

Tower-Modell

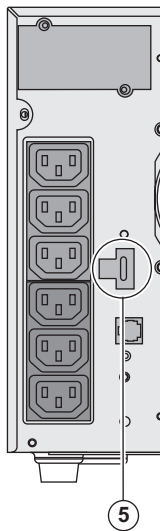

Anschluss und Test der Fernbetätigungen



- 1 - Prüfen, dass die USV abgeschaltet ist und dass sie nicht an das Stromnetz angeschlossen ist.
- 2 - Die Schrauben lösen und den Steckverbinder (5) abnehmen.
- 3 - Einen isolierten Trockenkontakt vom Typ 'normal geschlossen' (max. 60 Vdc/ 30 Vac, max. 1 A, max. Kabelquerschnitt 0,75 mm²) zwischen den beiden Pins des Steckverbinders (5) anschließen.

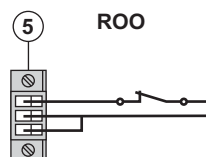

Kontakt offen: Abschaltung der USV
 Kontakt geschlossen: Einschaltung der USV (wenn die USV an das Stromnetz angeschlossen ist und das Stromnetz Strom führt).

Anmerkung: Das lokale Ein/Aus durch die Taste (27) hat Vorrang vor dem Fernabschaltkontakt.

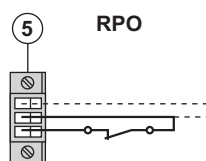

Kontakt offen: Abschaltung der USV
 Für die Rückkehr in Normalbetrieb den externen Fernabschaltkontakt deaktivieren und die USV mit der Taste (27) wieder einschalten.

- 4 - Den Steckverbinder (5) in seinen Steckplatz an der RückPage der USV einstecken.
- 5 - Die USV gemäß den weiter oben beschriebenen Verfahren anschließen und wieder starten.
- 6 - Den externen Fernabschaltkontakt aktivieren, um die Funktion zu testen.



Achtung: Dieser Steckverbinder darf ausschließlich an SELV-Stromkreise (Schutzkleinspannung) angeschlossen werden.



4. Kundenspezifische Anpassung und Abfrage der Messwerte

4.1 Darstellungsmöglichkeiten des Displays

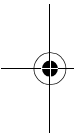
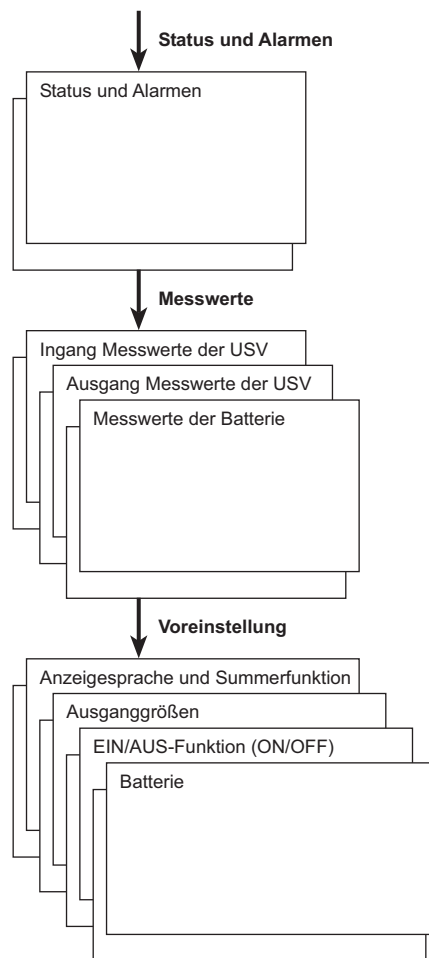

4.2 Abfrage der Messwerte

Durch wiederholte Betätigung der Scroll-Taste (25) können ggf. anstehende Alarme sowie die Messwerte für Spannung, Strom, Frequenz, Ausgangsleistung und Autonomiezeit der Batterie aufgerufen werden.

4.3 Kundenspezifische Anpassung über Bedienfeld

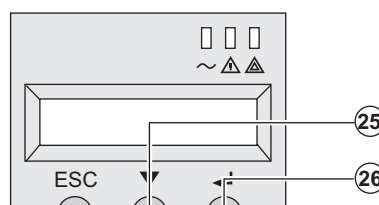

- Scroll-Taste mehrmals drücken (25) um in das Menü für die kundenspezifische Anpassung zu gelangen.
- Mit Hilfe der Betätigungstaste (26) können die einzeln ausgewählten Einstellungen gespeichert werden.
- Durch erneutes Drücken der Betätigungstaste (26) können die ausgewählten Einstellungen abgespeichert werden.



4. Kundenspezifische Anpassung und Abfrage d

Ausgangsgrößen

| Funktion | Werkseitige Voreinstellung | Verfügbare Einstellungen | Anmerkung |
|--|---|---|---|
| Ausgangsspannung ⁽¹⁾ | 230 Volt AC | 200/208/220/240/250 Volt AC | |
| Frequenzwandler ⁽¹⁾ | Inaktiv | Aktiv | Umschalteschaltung angeschlossene NRE zulässig. |
| Ausgangsfrequenz ⁽¹⁾ | Automatische Auswahl | 50/60 Hz | Auswahl bei aktivierter Frequenz |
| Umschaltung auf Netz 2 (Bypass) ⁽¹⁾ | wenn Netz 2 innerhalb der zulässigen Toleranzen | wenn Netz 2 außerhalb der zulässigen Toleranzen | |
| Überlastvermögen ⁽¹⁾ | 100% | 30 / 50 / 70% | Alarm bei Grenzwert |

(1) Diese Einstellungen können nur bei ausgeschalteter USV verändert werden.

Eine genauere Beschreibung der Einstellungen steht unter der USV-Software **Personal Software**.

EIN/AUS-Funktion (ON/OFF)

| Funktion | Werkseitige Voreinstellung | Verfügbare Einstellungen | Anmerkung |
|---|----------------------------|--------------------------|---|
| USV-Start im Batteriebetrieb | Aktiv | Inaktiv | |
| Automatischer Neustart | Aktiv | Inaktiv | Automatischer Neustart |
| Energiesparfunktion | Inaktiv | Aktiv | Bei Aktivierung dieser Funktion automatische Abschaltung bei einem Auslastungsgrad |
| Erkennung des korrekten Netzanschlusses Phase/ N-Leiter (SWF) | Inaktiv | Aktiv | Bei Aktivierung dieser Funktion ausgeschaltet (Stellung der Phase/ N-Leiter erkannt w |

Batterie

| Funktion | Werkseitige Voreinstellung | Verfügbare Einstellungen | Anmerkung |
|-----------------------------------|---|--|-----------------------------|
| Batterietest | einmal pro Woche | Kein Test / täglich / einmal pro Monat | |
| Voralarm Ende der Autonomiezeit | 20% | 0 bis 100% | Auflösung |
| Autonomiezeit (Batteriekapazität) | Automatische Erfassung der vorhandenen Batteriemodule | 13 bis 200 Ah | |
| Schutz gegen Tiefentladung | Aktiv | Inaktiv | Bei Aktivierung Verlust der |

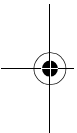



5. Wartung und Service

5.1 Betriebsstörungen



Bei Aufleuchten der LED (21) oder (22) liegt eine Betriebsstörung oder ein Alarmzustand vor. Zur Abschaltung des Summers Taste (24) drücken.

| | Fehleranzeige | Fehlerursache | Fehlerbehebung |
|----|---|---|--|
| 1 | Die USV geht nicht an, Das alphanumerische Display zeigt folgende Meldung: COLD START NOK CHECK AC WIRING | Es ist entweder keine Netzspannung vorhanden oder sie ist an den Ausgang der USV angeschlossen. | Prüfen Sie, ob die ordnungsgemäß angeschlossen ist |
| 2 | LED (22) leuchtet auf und LED (11) (SWF-Funktion) an der USV-Rückseite leuchtet auf. Das alphanumerische Display zeigt folgende Meldung: ANSCHLUSS FALSCH UEBERPRUEFEN | Fehlerhafter Anschluss von Phase und Neutralleiter des Eingangsnetzes. Die USV lässt sich nicht einschalten. | <ul style="list-style-type: none"> ▶Bei TT-Netzen (S geerdet) Netzans korrigieren. Hierzu Schukostecker ab 180° drehen oder durch Wartungs-p vornehmen lassen ▶Bei allen anderen SWF-Funktion de |
| 3 | LED (22) leuchtet auf. Das alphanumerische Display zeigt folgende Meldung: KEINE BATTERIE PRUEFE ANSCHLUSS | Die Batterie ist falsch angeschlossen. | Batterieanschluss (siehe Abschnitt 5 des Batteriemodu |
| 4 | LED (22) leuchtet auf. Das alphanumerische Display zeigt folgende Meldung: BATTERIEFEHLER SERV NOTWENDIG | Es wurde eine Batteriestörung festgestellt. | Batterie austausch Abschnitt 5.2: "Au Batteriemoduls"). Kundendienst ver |
| 5 | LED (21) leuchtet auf. Das alphanumerische Display zeigt folgende Meldung: UEBERLASTMELDUNG LAST REDUZIEREN | Der Belastungsgrad übersteigt den parametrierten Wert der Überlast oder die Kapazität der USV. | Leistungsaufnah angeschlossenen überprüfen und w Verbraucher abs Belastungsgrad ü |
| 6 | LED (22) leuchtet auf. Das alphanumerische Display zeigt folgende Meldung: LAST UNGESICHERT UEBERLAST | Die USV ist überlastet. Die angeschlossenen Verbraucher werden über den Bypass direkt vom Netz gespeist. | Leistungsaufnah angeschlossenenüberprüfen und w Verbraucher abs |
| 7 | LED (22) leuchtet auf. Das alphanumerische Display zeigt folgende Meldung: LAST REDUZIEREN USV NEU STARTEN | Infolge wiederholt aufgetretener Überlast ist die USV in der Bypassposition blockiert. Die angeschlossenen Verbraucher werden direkt vom Netz gespeist. | Leistungsaufnah angeschlossenenüberprüfen und w Verbraucher abs Verbraucher abs Schalten Sie die U wieder ein, um in Betrieb zurückzuk |
| 8 | LED (22) leuchtet auf. Das alphanumerische Display zeigt folgende Meldung: FEHLER UEBERLAST LAST REDUZIEREN | Die USV wurde wegen einer unzulässigen Überlast abgeschaltet. | Leistungsaufnah angeschlossenenüberprüfen und w Verbraucher abs |
| 9 | LED (22) leuchtet auf. Das alphanumerische Display zeigt folgende Meldung: VERBRAUCHER KURZSCHLUSS | Die USV wurde aufgrund eines Kurzschlusses im Ausgangskreis abgeschaltet. | Verbraucherkreis (Anschlüsse, Gerä |
| 10 | LED (22) leuchtet auf | Es liegt eine intern | Kundendienst |

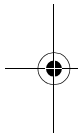



5. Wartung

Betriebsstörungen bei einer USV mit HotSwap MBP-Modul



| | Fehleranzeige | Fehlerursache | Fehlerbeseitigung |
|----|--|---|---|
| 12 | Die angeschlossenen Verbraucher werden nicht versorgt, wenn der Drehschalter (49) des HotSwap MBP-Moduls in der Stellung "By-pass" steht. | <ul style="list-style-type: none"> ▶ Die Verbraucher sind an den Ausgang der USV anstatt an das HotSwap MBP-Modul angeschlossen. ▶ Das Netzkabel ist an den USV-Eingang anstatt an das HotSwap MBP-Modul angeschlossen. | Anschlüsse der USV und des HotSwap MBP-Moduls überprüfen. |
| 13 | Die angeschlossenen Verbraucher werden nicht versorgt, wenn der Drehschalter (49) des HotSwap MBP-Moduls in der Stellung "Normal" steht. | <ul style="list-style-type: none"> ▶ Die USV ist ausgeschaltet. ▶ Die Anschlussverbindungen zwischen USV und HotSwap MBP-Modul sind fehlerhaft. | <ul style="list-style-type: none"> ▶ USV einschalten. ▶ Anschlüsse der USV und des HotSwap MBP-Moduls überprüfen. |
| 14 | Die angeschlossenen Verbraucher werden bei Netzausfall nicht weiter versorgt. | <ul style="list-style-type: none"> ▶ Der Drehschalter (49) des HotSwap MBP-Moduls steht in Stellung "By-pass". ▶ Die Anschlussverbindungen zwischen USV und HotSwap MBP-Modul sind fehlerhaft. | <ul style="list-style-type: none"> ▶ Drehschalter (49) des HotSwap MBP-Moduls auf "Normal" bringen. ▶ Anschlüsse der USV und des HotSwap MBP-Moduls überprüfen. |

Bei Störungen mit Abschaltung der USV nach Behebung des Fehlers erneut EIN/AUS-Taste drücken.

5.2 Austausch des Batteriemoduls

Sicherheitsmaßnahmen:



Die Batterie hat einen hohen Kurzschlußstrom und kann Stromschläge verursachen. Bei Arbeiten an Batterien sind daher folgende Sicherheitsmaßnahmen einzuhalten:

- ▶ Armbanduhren, Ringe, Armreifen und sonstige an Händen oder Armen getragene Metallgegenstände entfernen.
- ▶ Werkzeuge mit Isoliergriff verwenden.

Ausbau des Batteriemoduls

RT-Modell

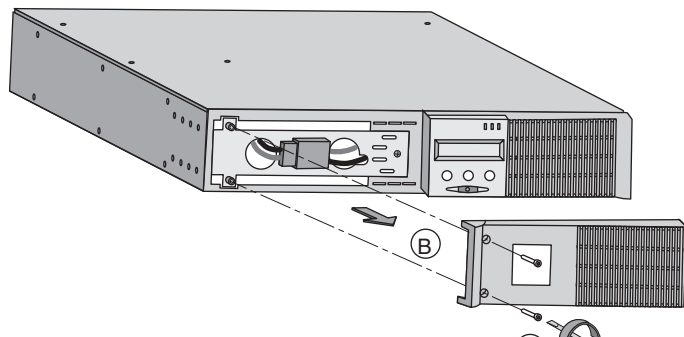

- A - Linken Teil (2 Schrauben).
- B - Blech abnehmen.



5. Wartung und Service

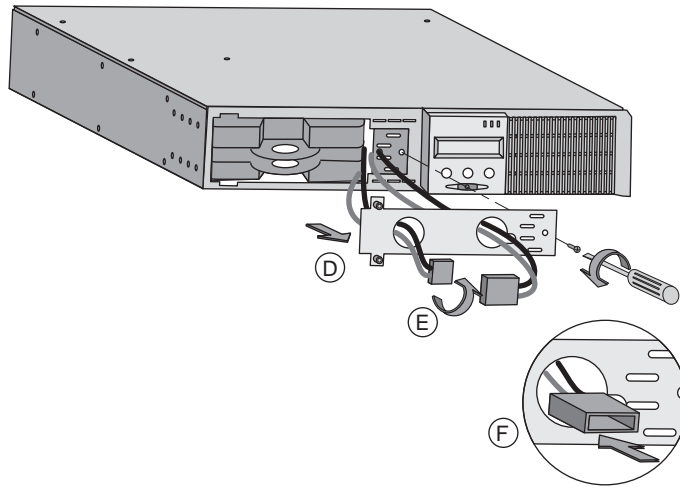

D - Batterie-Schutzabdeckung (2 Schrauben).
E - Steckverbinder drehen.
F - Steckverbinder durch den Chassis herausziehen.

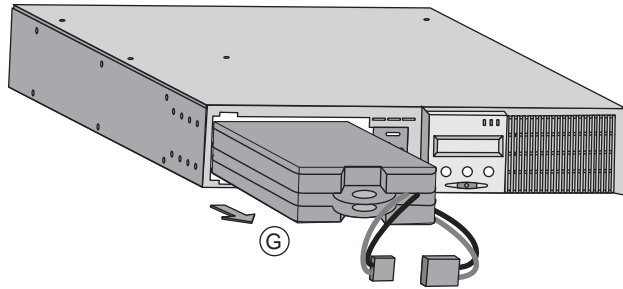

G - Batteriemodul durch die Kunststoffflasche herausziehen und neues einsetzen.

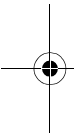

Tower-Modell

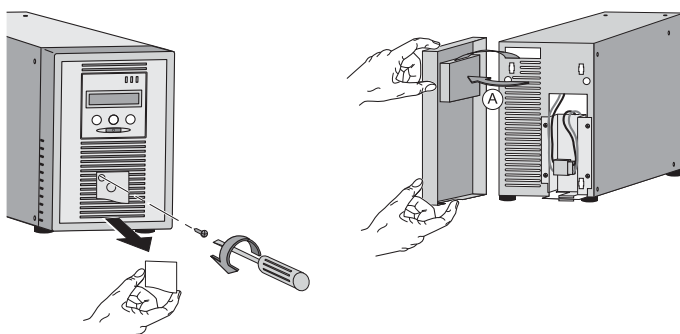

A - Frontblende abnehmen und die USV legen.



B - Batteriemodul durch die Kunststoffflasche herausziehen (2 Steckverbinder abklemmen und die Kabeln ziehen!).



5. Wartung

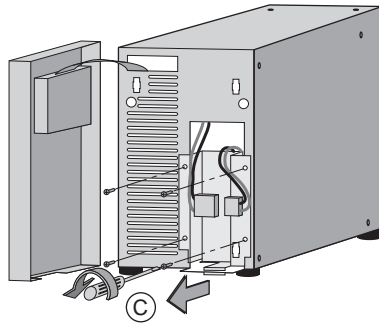

C - Die 4 Befestigungsschrauben der Batterie-Schutzabdeckung entfernen.

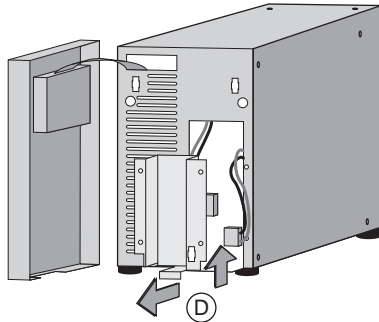

D - Batterie-Schutzabdeckung entfernen.

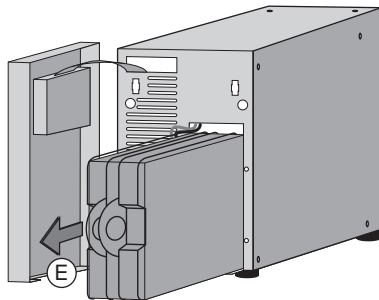

E - Batteriemodul in die Buchse stecken.

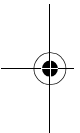

Einbau des neuen Batteriemoduls

Die oben beschriebenen Handgriffe in umgekehrter Reihenfolge ausführen.



- Zur Gewährleistung der Sicherheit und des Betriebsverhaltens dürfen nur Austauschmodule eingesetzt werden, die mit den eingebauten Batterien baugleich sind.
- Es ist sicherzustellen, dass der Batteriestecker vollständig in die zugehörige Buchse des Gerätes eingesteckt ist.



5. Wartung und Service

5.3 Wartung und Service bei USV-Anlagen mit HotSwap MBP-Modul

RT-Modell

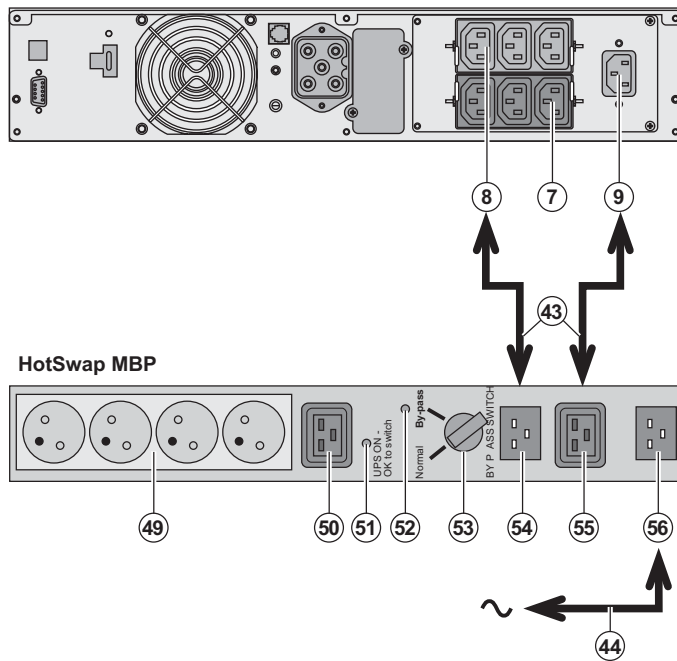

Das **HotSwap MBP-Modul** ermöglicht die Wartung und ggf. den Austausch des Moduls ohne die Spannungsversorgung der angeschlossenen Verbraucher unterbrechen zu müssen (HotSwap-Funktion).

Wartung:

1 - Drehschalter (**53**) in die Position "Normal" bringen. Die rote LED (**51**) am **HotSwap MBP-Modul** leuchtet an, was zeigt an, dass die angeschlossenen Verbraucher direkt aus dem Netz versorgt werden.

2 - USV durch Betätigung der Taste (**27**) an der Frontseite des Moduls ausschalten. Die LED (**51**) am **HotSwap MBP-Modul** erlischt; anschließend kann die USV abgeklemmt und ausgetauscht werden.

Rückkehr in Normalbetrieb:

1 - Korrekten Anschluss der Verbraucher an das Netz.

2 - USV durch Betätigung der Taste (**27**) an der Frontseite des Moduls einschalten. Die LED (**51**) am **HotSwap MBP-Modul** leuchtet an, was zeigt an, dass die Verbraucher über das HotSwap MBP-Modul versorgt werden (andernfalls liegt ein Fehler vor).

3 - Drehschalter (**53**) in die Position "Normal" bringen; die rote LED (**51**) am **HotSwap MBP-Modul** leuchtet an.

4 - Der Schutz und die Verteilung der Verbraucher erfolgt über das HotSwap MBP-Modul.

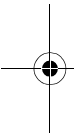



5. Wartung

5.4 Trainingscenter



Um Ihnen eine optimale Betriebsführung Ihrer Anlage sowie eine kompetente Fehleranalyse ermöglichen, bietet EATON umfangreiche Kundens Schulungen in englischer und französischer Sprache.

For further information, please visit our website: www.eaton.com

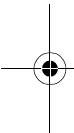



6. Anhang

6.1 Technische Daten

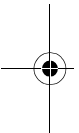
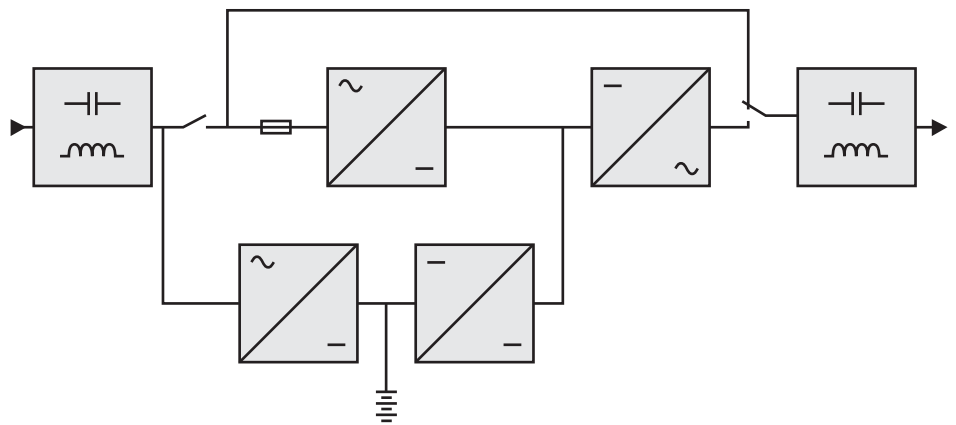

| | EX 700 | EX 1000 EX 1000 RT | EX 1500 EX 1500 RT |
|------------------------------------|--|--|--|
| Ausgangsleistung | 700 VA / 630 W | 1000 VA / 900 W ⁽³⁾ | 1500 VA / 1350 W ⁽⁴⁾ |
| Einspeisetz | Einphasennetz 100 / 120 / 140 / 160 bis 284 V ⁽⁵⁾ 50/60 Hz (automatische Einstellung) > 0,95 | | |
| USV-Ausgang | Einphasennetz 230 V ±3% ⁽⁶⁾ 50/60 Hz ±0,5% ⁽⁷⁾ < 4% bei linearer Last, < 6% bei nichtlinearer Last 102% unbegrenzt, 130% 12s, > 130% 2s | | |
| Strom | 3 A ⁽⁸⁾ | 4,3 A ⁽⁸⁾ | 6,5 A ⁽⁸⁾ |
| Batterie | 6x12 V - 7 Ah, verschlossene, wartungsfreie Bleibatterien | 3x12 V - 7 Ah, verschlossene, wartungsfreie Bleibatterien | 3x12 V - 9 Ah, verschlossene, wartungsfreie Bleibatterien |
| Umgebungsbedingungen | <ul style="list-style-type: none"> ▶Geräuschpegel < 38 dBA ▶Betriebstemperatur 0°C bis 40°C ▶Luftfeuchtigkeit 20% to 90% (ohne Kondensation) ▶Erdableitstrom < 1,1 mA ▶Lagertemperatur -25°C bis 40°C ▶Aufstellhöhe 1000 m | | |
| Normen und Zertifizierungen | <ul style="list-style-type: none"> ▶Sicherheit IEC/EN 62040-1-1, EN 60950-1 (RD) ▶Betriebsverhalten IEC/EN 62040-3 ▶EMV EN 50091-2/IEC 62040-2 class B, IEC 61000-4-2/-3/-4/-6-8/-11, IEC 61000-3-2/-3 | | |



6.2 Fachbegriffe

| | |
|--|---|
| Auslastungsgrad | Verhältnis der durch die angeschlossenen Verbraucher aufgenommene Leistung zur verfügbaren USV-Leistung. |
| Autonomiezeit | Zur Versorgung der Verbraucher nutzbare Batteriekapazität. |
| Batterietest | Interne Überprüfung der Batterie zur Feststellung ihres Betriebszustandes. |
| FlexPDU-Modul | Mit der USV verbundener Installationsverteiler zur Montage in Standard- oder Rack-Systemen. Es gibt mehrere Ausführungen des Verteilers mit unterschiedlichen Funktionen. |
| Frequenzwandler | Betriebsart der USV zur Anpassung von Eingangs- und Ausgangsfrequenzen (z. B. 60 Hz -> 50 Hz). |
| HotSwap MBP-Modul | Modul zur manuellen Umgehung der USV zu Wartungszwecken. Es gibt verschiedene Ausführungen des HotSwap MBP -Moduls mit unterschiedlichen Funktionen. |
| Kundenspezifische Anpassung | Programmierung bestimmter Kenndaten durch Änderung der voreingestellten Parameter. Einige Einstellungen können über die USV-Solution Pac von EATON vorgenommen werden. |
| Netz 2 (Bypass) | Ersatzeinspeisung, die eine Umgehung des Wechselrichters durch den NRE-Zweig im Überlastfall sowie eine Freischaltung bei Wartung ermöglicht. |
| Netz 1 (Gleichrichter) | Normales Einspeisenetz der USV. |
| Programmierbare Steckdosen | Steckdosen, die bei Batteriebetrieb automatisch abgeworfen werden (Abwurfverzögerung über Software Personal Solution Pac). Die Steckdosen sind zu jeweils zwei Gruppen zusammengefasst. |
| Start im Batteriebetrieb | Betriebsart, die ein Einschalten der an die USV angeschlossenen Verbraucher bei fehlender Netzeinspeisung erlaubt (USV arbeitet im Batteriebetrieb). |
| Tiefentladung | Entladung der Batterie unter einen zulässigen Grenzwert, die eine Schädigung der Batterie zur Folge hat. |
| USV | Unterbrechungsfreie Stromversorgung. |
| USV-Start/Stop über Software | Aktivierung/Deaktivierung von Start/Stop-Bedingungen für die angeschlossenen Rechner-Managementsoftware der angeschlossenen Rechner-Systeme. |
| Verbraucher | An die USV angeschlossene Geräte und Verbraucher. |
| Voralarm "Ende der Autonomiezeit" | Grenzwert der Batteriespannung, der das bevorstehende Ende der Autonomiezeit anzeigt, so dass entsprechende Maßnahmen auf Verbraucherseite getroffen werden können. |

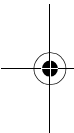

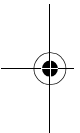



www.eaton.com

EX
700 - 1000
1000 RT -
EXB 1000
EXB 1000

**Manuale
e di utiliz**

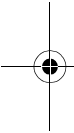

Pulsar Series

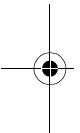



Grazie per aver scelto un prodotto EATON per la sicurezza delle vostre applicazioni.

La gamma **EX** è stata elaborata con la più grande cura.

Per sfruttare nel modo migliore le performance del vostro **ASI (Alimentazione Senza Interruzione)**, leggere attentamente questo manuale.

Prima di installare **EX**, leggere attentamente il libretto contenente le norme di sicurezza e le istruzioni del presente manuale.

Vi invitiamo a scoprire l'offerta della EATON, come pure le opzioni della gamma **EX** visitando www.eaton.com o contattando il vostro rappresentante EATON.

Tutela dell'ambiente

La società EATON si è impegnata in una politica di protezione e preservazione dell'ambiente. I nostri prodotti sono sviluppati secondo un metodo di concezione che tiene conto del processo di produzione.

Sostanze

Questo prodotto non contiene né CFC, né HCFC, né amianto.

Imballaggio

Per migliorare il trattamento dei rifiuti e facilitarne il riciclaggio, separare gli elementi dell'imballaggio.

- ▶ Il cartone è composto da più di un 50% di cartone riciclato.
- ▶ I sacchetti e i sacchi sono in polietilene.
- ▶ I materiali che costituiscono l'imballo sono riciclabili e sono marcati con simbolo di identificazione.

| Materiali | Abbreviazione | Numero nel simbolo |
|-----------------------------|---------------|--------------------|
| Polietilene teraftalato | PET | 01 |
| Polietilene ad alta densità | HDPE | 02 |
| Cloruro di polivinile | PVC | 03 |
| Polietilene a bassa densità | LDPE | 04 |
| Polipropilene | PP | 05 |
| Polistirene | PS | 06 |

Per l'eliminazione dell'imballo, seguire le regolamentazioni locali in vigore.

Fine della vita utile

La società EATON si è impegnata a trattare i prodotti in fin di vita secondo le regolamentazioni locali. La società EATON lavora con società che si incaricano della raccolta e dell'eliminazione dei prodotti in fin di vita.

Prodotto

Il prodotto è composto da materiali riciclabili.

Lo smantellamento e la distruzione dei prodotti devono avvenire nel rispetto della regolamentazione per i rifiuti.

I prodotti in fin di vita devono essere depositati in un centro per il trattamento dei rifiuti e

Batteria

Il prodotto contiene delle batterie al piombo che devono essere trattate secondo le regolamentazioni locali.

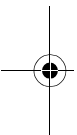



Introduzione

Pittogrammi utilizzati



Istruzioni da seguire tassativamente.



Informazioni, consigli, guida.



Indicazione visiva da osservare.



Azione da eseguire.



Segnalazione acustica.

Le convenzioni adottate per rappresentare le spie all'interno delle illustrazioni sono le seguenti:



Spia spenta.



Spia accesa.



Spia lampeggiante.

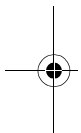



1. Presentazione

1.1 Posizioni standard

Posizione tower

Posizione slot

1.2 Vista posteriore

EX 700 / 1000 / 1500

EX 1000 RT / 1500 RT

EX EXB (modulo batteria opzionale)

EX EXB RT (modulo batteria opzionale)

1.3 Pannello di visualizzazione e di comando

2. Installazione

2.1 Apertura dell'imballaggio e verifica del contenuto

2.2 Installazione del modello RT nella posizione tower

2.3 Installazione del modello RT in uno slot

2.4 Porte di comunicazione

Raccordo della porta di comunicazione RS232 o USB (facoltativa)

Installazione delle schede di comunicazione (opzione)

2.5 Caratteristiche della porta di comunicazione tramite contatti

2.6 Raccordi con un modulo FlexPDU (Power Distribution Unit)

2.7 Raccordi con un modulo HotSwap MBP

Funzionamento del modulo HotSwap MBP

2.8 Raccordo di un ASI privo di modulo FlexPDU o HotSwap MBP

3. Utilizzo

3.1 Messa in servizio e funzionamento normale

3.2 Funzionamento su batteria

3.3 Ritorno della rete elettrica

3.4 Arresto dell'ASI

3.5 Utilizzo delle funzioni di controllo remoto dell'ASI

4. Personalizzazione e accesso alle misure

4.1 Sinottico del display

4.2 Accesso alle misure

4.3 Personalizzazione tramite il pannello di comando

4.4 Personalizzazione tramite software esterno

5. Manutenzione

5.1 Anomalie

Anomalie su un ASI dotato di modulo HotSwap MBP

5.2 Sostituzione del modulo batteria

Richiamo sulle istruzioni di sicurezza

Smontaggio del modulo batteria

Rimontaggio del nuovo modulo batteria

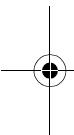



1. Presentazione

1.1 Posizioni standard

Posizione tower

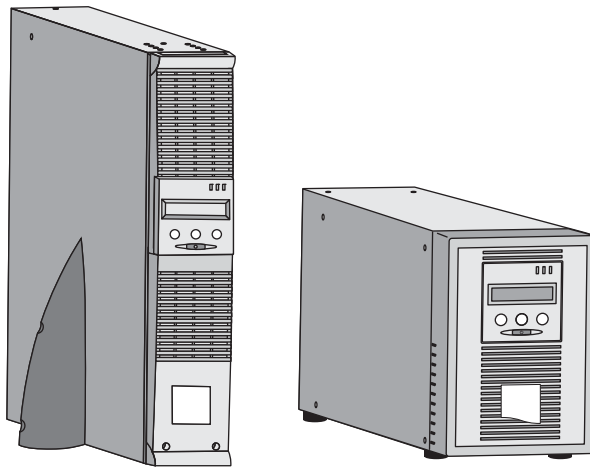

| Tabella delle dimensioni in mm | |
|--------------------------------|---|
| EX 700 | 2 |
| EX 1000 | 2 |
| EX 1000 RT | 8 |
| EX 1500 | 2 |
| EX 1500 RT | 8 |
| EX EXB | 2 |
| EX EXB RT | 8 |

| Tabella delle masse in | |
|------------------------|---|
| EX 700 | 1 |
| EX 1000 | 1 |
| EX 1000 RT | 1 |
| EX 1500 | 1 |
| EX 1500 RT | 2 |
| EX EXB | 2 |
| EX EXB RT | 2 |

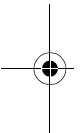

Posizione slot

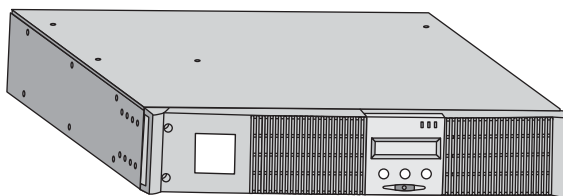



1.2 Vista posteriore

EX 700 / 1000 / 1500

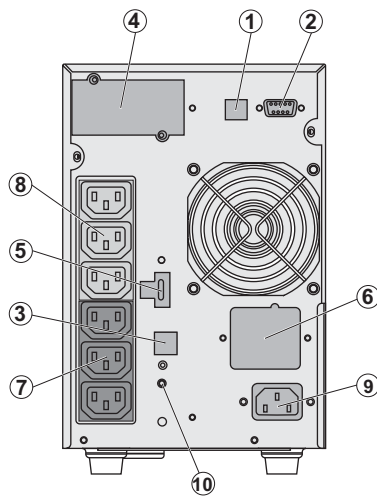

- (1) Porta di com
- (2) Porta di com
- contatti secchi
- (3) Connettore c
- automatico di u
- (eccetto EX 700
- (4) Sede per una
- opzionale.
- (5) Connettore p
- comando Avvio
- arresto di emer
- (6) Connettore p
- modulo batteria
- (7) Gruppo di 3
- raccordo diretto
- (8) Gruppo di 3
- diretto degli im
- (9) Presa per il r
- di alimentazione
- (10) Spia di seg
- fase/neutro dell

EX 1000 RT / 1500 RT

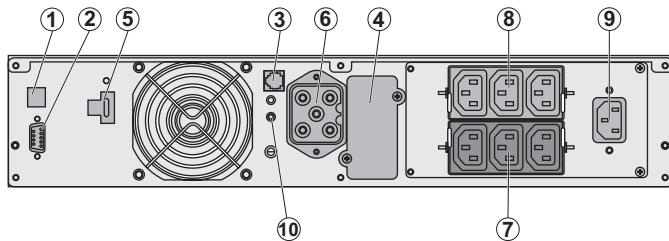
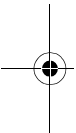

EX EXB (modulo batteria opzionale)

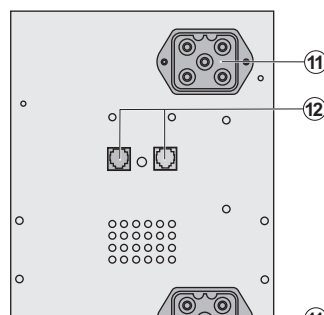

- (11) Connettori
- batteria (verso l
- batteria)
- (12) Connettori
- automatico dei



1. Presentazione

EX EXB RT (modulo batteria opzionale)

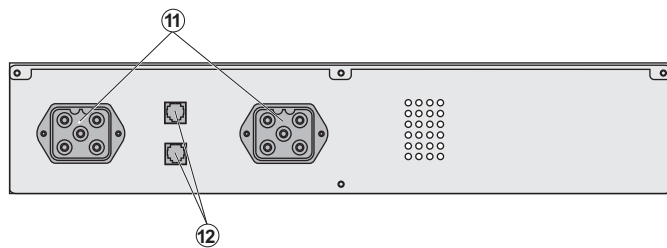

1.3 Pannello di visualizzazione e di comando

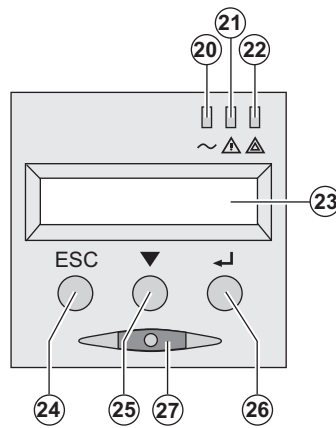

- (20) Spia impianti protetti
- (21) Spia di funzionamento
- (22) Spia impianti non protetti
- (23) Display alfanumerico
- (24) Pulsante di uscita/ritorno
- (25) Pulsante di scorrimento
- (26) Pulsante di convalida
- (27) Pulsante di comando (ON/OFF) dell'ASI e delle

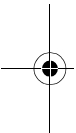



2.

2.1 Apertura dell'imballaggio e verifica del contenuto

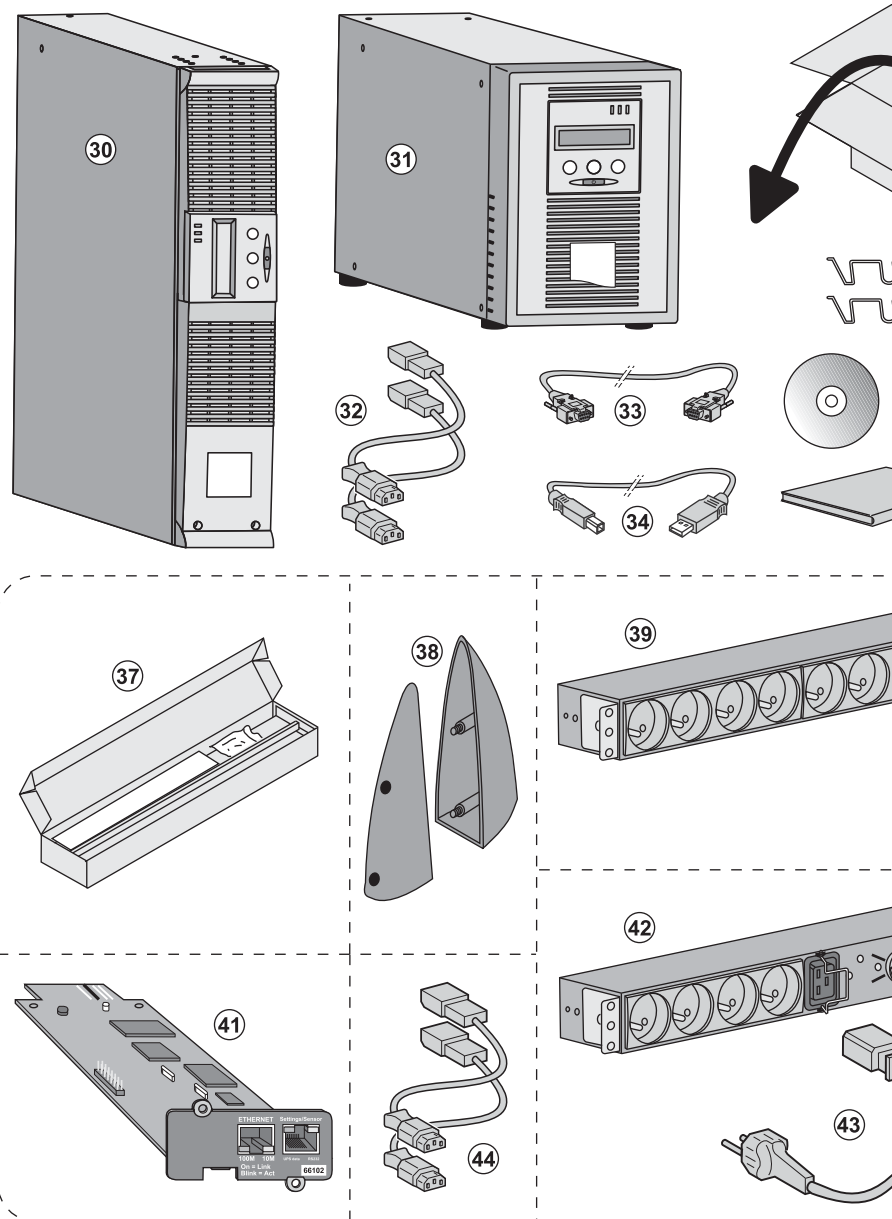

(30) EX 700, 1000, 1500.

(31) EX 1000 RT, 1500 RT.

(32) 2 cavi per collegare gli impianti.

(33) Cavo di comunicazione RS232.

(34) Cavo di comunicazione USB.

(35) Sistema di fissaggio dei cavi di alimentazione

**Componenti forniti solo in alcune
opzione:**

(37) Kit di montaggio all'interno
pollici.

(38) 2 piedini di sostegno in pos
modello RT).

(39) Modulo FlexPDU (opzione



2. Installazione

2.2 Installazione del modello RT nella posizione tower

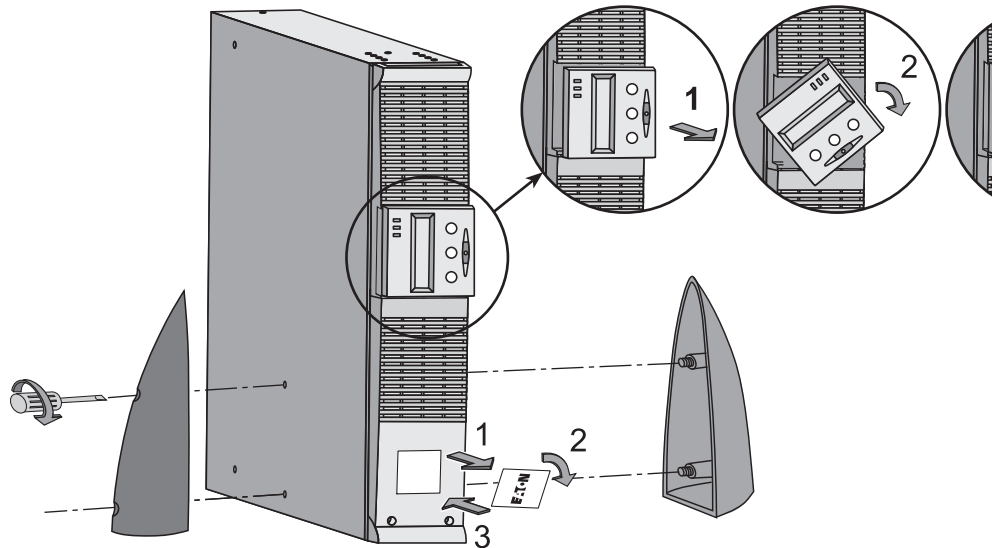

2.3 Installazione del modello RT in uno slot

Si raccomanda di installare il/i modulo/i batteria EXB il più in basso possibile nel rack e di collocarli

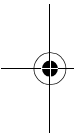

Per il montaggio del modulo sulle guide, seguire i passaggi da 1 a 4.

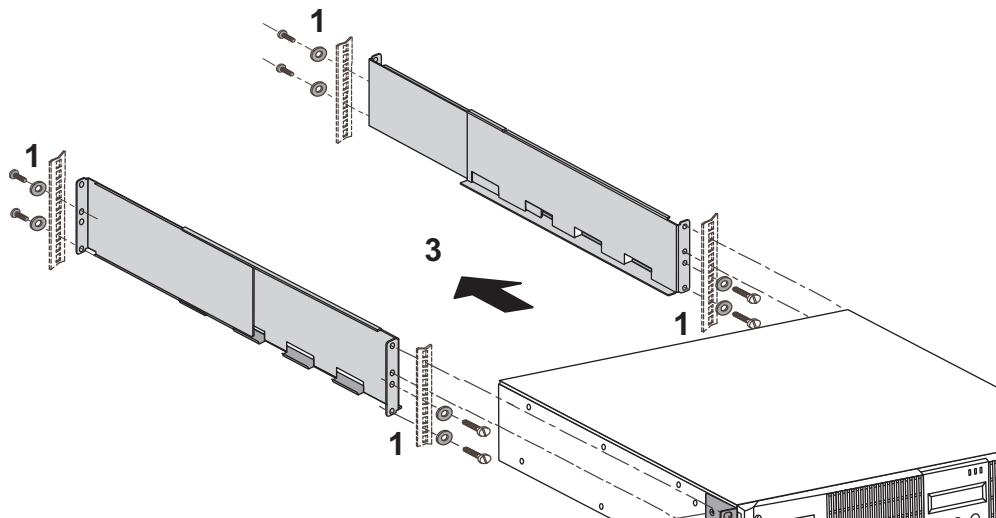



2.4 Porte di comunicazione

Raccordo della porta di comunicazione RS232 o USB (facoltativa)



La porta di comunicazione RS232 e la porta di comunicazione USB non possono funzionare contemporaneamente.

Modello Tower

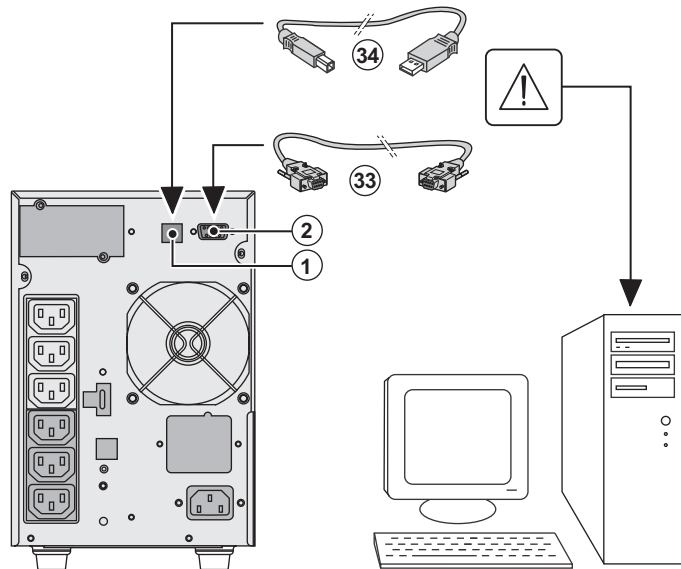

1 - Collegare il cavo di comunicazione RS232 (33) o USB (34) all'apparecchio.

2 - Collegare l'apparecchio alla porta di comunicazione RS232 o USB dell'ASI.

L'ASI è ora in grado di eseguire il software di amministrazione e configurazione.

Modello RT

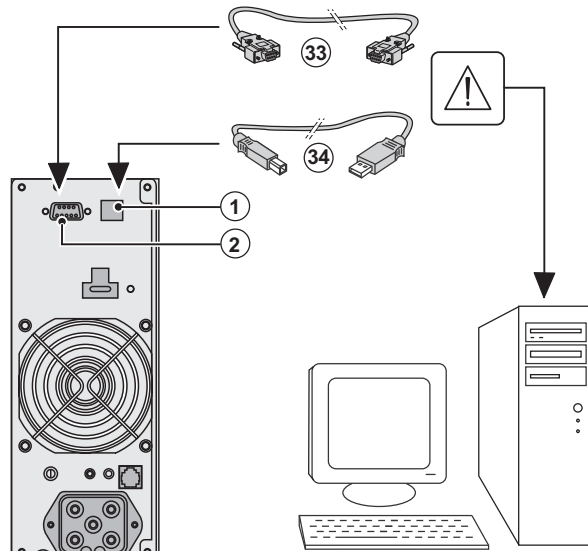

2. Installazione

Installazione delle schede di comunicazione (opzione)

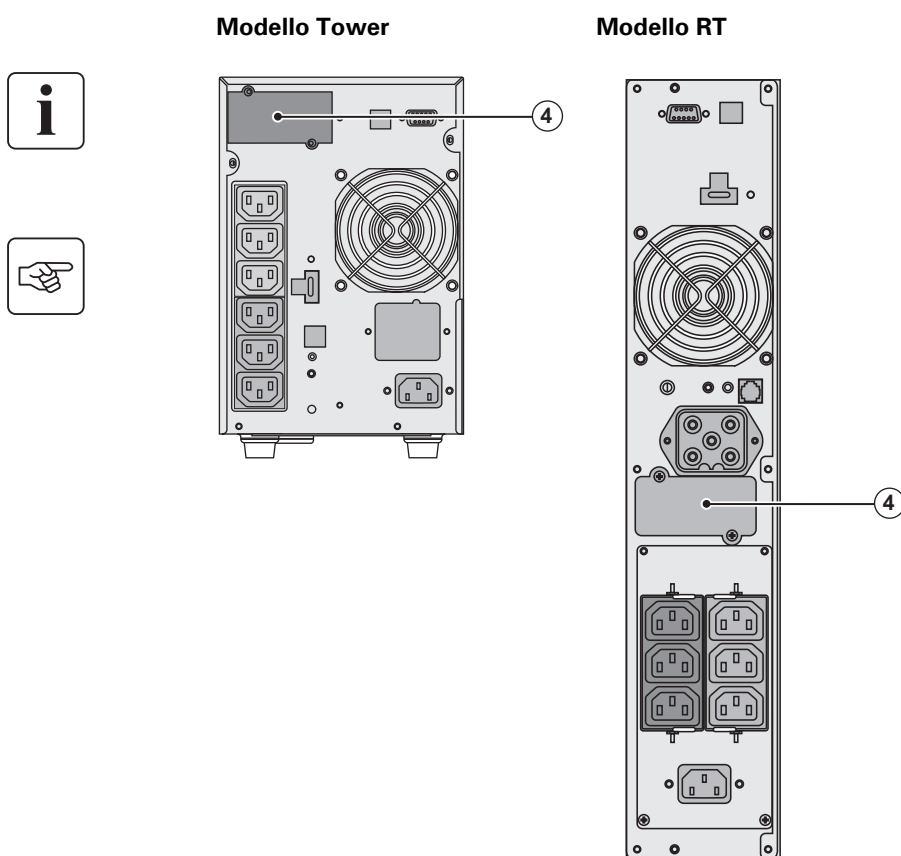

Non è necessario arrestare il funzionamento dell'ASI prima di installare la scheda di comunicazione. (4): Alloggiamento ad adattare la scheda di comunicazione.

- 1 - Rimuovere la piastra dell'ASI fissata tramite viti.
- 2 - Inserire la scheda di comunicazione all'interno dell'apposito alloggiamento.
- 3 - Fissare la piastra della scheda di comunicazione con le apposite viti.

2.5 Caratteristiche della porta di comunicazione tramite contatti (2)

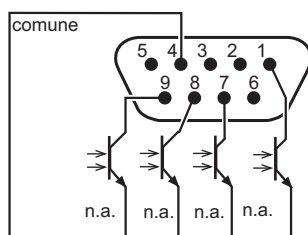

- Contatti maschi 2, 3, 5 e 6 : non utilizzati,
- Contatto maschio 1 : funzionamento su By-pass automatico,
- Contatto maschio 4 : comune utenza,
- Contatto maschio 7 : preallarme di fine autonomia,
- Contatto maschio 8 : apparecchiature utenza protezione,
- Contatto maschio 9 : funzionamento a batteria.

n.a. : contatto normalmente aperto.

Nel momento in cui un'informazione è attiva, il contatto è chiuso tra il contatto maschio comune 4 e il maschio dell'informazione corrispondente.

Caratteristiche dei contatti (optoaccoppiatori)

- Voltaggio: 48 V CC max.,
- Corrente: 25 mA max.,
- Potenza: 1,2 W.



2.6 Raccordi con un modulo FlexPDU (Power Distribution Unit) (Opzione)

Modello RT

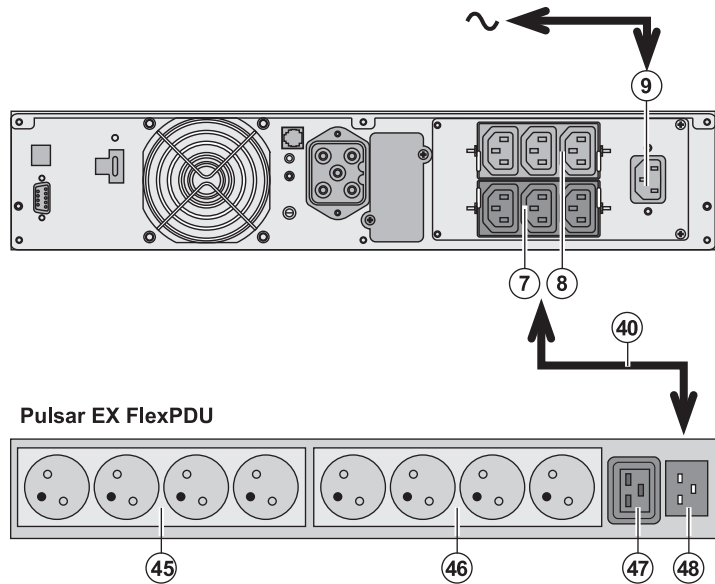

1 - Collegare la rete elettrica alla rete elettrica di alimentazione e proteggere.

2 - Collegare la rete elettrica del modulo alla presa di uscita (40) IEC 10 e queste prese di colore rosso.

3 - Collegare gli interruttori (46) e (47) del modulo alle prese variabili del modulo FlexPDU.

4 - Bloccare i cavi con le flange metalliche.

2.7 Raccordi con un modulo HotSwap MBP (Opzione)

La funzione del modulo **HotSwap MBP** è quella di consentire la manutenzione ed eventuale sostituzione dell'ASI senza interferire sull'alimentazione elettrica delle apparecchiature collegate (funzionamento).

Modello RT

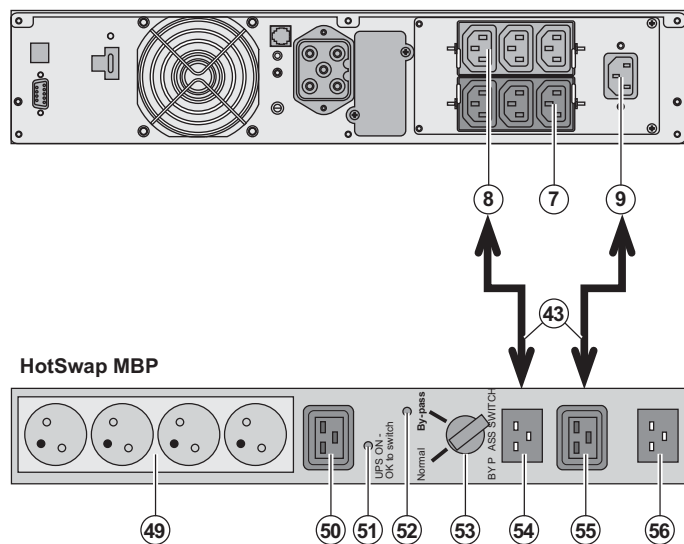

1 - Collegare la rete elettrica del modulo HotSwap MBP mediante il cavo (43).

2 - Collegare la rete elettrica dell'ASI (55) del modulo alla presa "UPS" (43) fornita dal modulo HotSwap MBP. Le prese sono con interruttori.

3 - Collegare la rete elettrica alla presa "UPS" del modulo HotSwap MBP, fornito. Questo modulo HotSwap MBP, per alimentare il modulo HotSwap MBP, è necessario un cavo di tipo 10A FR/DIN del tipo (art. 68439). Qualora l'alimentazione elettrica della rete elettrica do



2. Installazione

Funzionamento del modulo HotSwap MBP

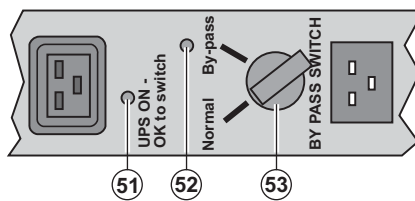

Il modulo **HotSwap MBP** è un commutatore rotativo (53) che permette di alimentare gli impianti son...
Normale: gli impianti sono alimentati dall'ASI.

By-pass: gli impianti sono alimentati dalla rete elettrica.

Attivazione dell'ASI con il modulo HotSwap MBP:

- 1 - Verificare che l'ASI sia collegato correttamente al modulo **HotSwap MBP**.
 - 2 - Portare il commutatore (53) in posizione Normale.
 - 3 - Avviare l'ASI premendo il pulsante Avvio/Arresto (27) sulla parte anteriore dell'ASI.
- Gli impianti sono ora alimentati dall'ASI.
 La spia (51) "UPS ON - OK to switch" si accende sul modulo **HotSwap MBP**.

Test del modulo HotSwap MBP

- 1 - Portare il commutatore (53) in posizione By-pass e verificare che gli impianti continuino ad essere alimentati.
- 2 - Riportare il commutatore (53) in posizione Normale.

2.8 Raccordo di un ASI privo di modulo FlexPDU o HotSwap MBP



Verificare che le indicazioni riportate sulla targhetta di identificazione situata nella parte posteriore dell'ASI corrispondano alla rete elettrica di alimentazione ed ai consumi elettrici reali degli impianti.

Modello Tower

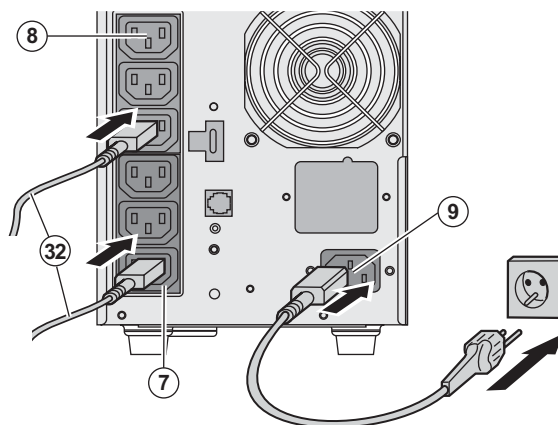

1 - Collegare la presa d'energia (9) alla rete elettrica tramite un cavo di alimentazione dell'apparato e proteggere.

2 - Collegare gli impianti ai cavi (32).

Collegare preferibilmente i cavi prioritari alle 3 prese (8) e i cavi non prioritari alle 3 prese (7) della coppia (1 e 2).

Per comandare o programmare l'ASI utilizzare uno dei software di gestione energetica forniti da Eaton.



Modello RT

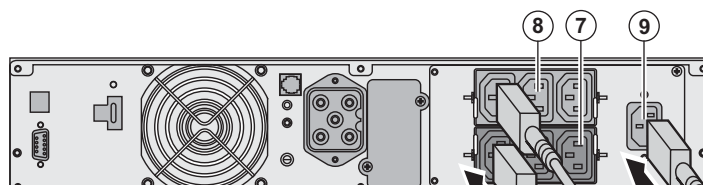



3.1 Messa in servizio e funzionamento normale



Durante il primo avviamento, la presenza della rete elettrica è indispensabile per rilevare il cablaggio. In seguito, l'apparecchio potrà essere avviato anche in assenza della rete elettrica.

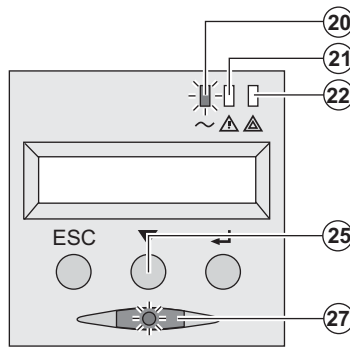

Premere il pulsante (27) per 1 secondo circa.

- Il cicalino emette un bip e tutte le spie si accendono contemporaneamente.
- Il cicalino emette in seguito 2 bip durante il primo avviamento. Il pulsante (27) rimane acceso per segnalare l'alimentazione in uscita.



Gli impianti collegati sono protetti dall'ASI.

- La spia (20) è accesa.

Se la spia (22) è accesa, si è verificato un "Anomalia".

- Con il funzionamento in modalità normale, lo scorrimento (25) permette di leggere le misure (tensione delle reti elettriche AC Normale, tensione di funzionamento, capacità della batteria e n° di batterie).

Personalizzazione dell'ASI



Se si ritiene di dover effettuare una personalizzazione specifica dell'ASI, si raccomanda di accedere alla personalizzazione dell'ASI in questo passaggio.

Questa modalità è accessibile agendo sui pulsanti del pannello di comando o tramite il software **Pac** per Windows incluso nel CD-ROM **Solution-Pac** di EATON.

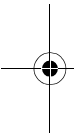

3.2 Funzionamento su batteria

Passaggio su batteria

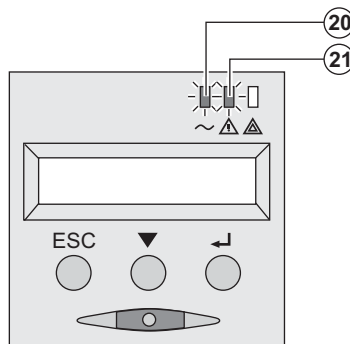

- Quando la rete elettrica non è più disponibile, l'ASI continua ad essere alimentato dalla batteria.

- Le spie (20) e (21) sono accese.
- L'allarme acustico emette un bip ogni 10 secondi.

Gli impianti collegati sono alimentati tramite la batteria.

Il display indica l'autonomia rimanente delle batterie.

Soglia di preallarme per fine autonomia della batteria

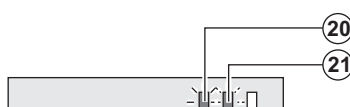

- Le spie (20) e (21) sono accese.
- L'allarme acustico emette un bip ogni 3 secondi.



3. Utilizzo

Fine dell'autonomia della batteria



- ▶ Tutte le spie sono spente.
- ▶ L'allarme acustico non emette alcun bip.



L'ASI è completamente all'arresto.

3.3 Ritorno della rete elettrica

Dopo l'interruzione, l'ASI si riavvia automaticamente al ritorno della rete elettrica (a meno che questa sia stata disattivata tramite la personalizzazione dell'ASI) e gli impianti sono nuovamente alimentati.

3.4 Arresto dell'ASI

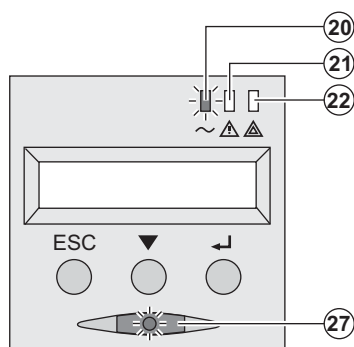

Tenere premuto il pulsante (27) per almeno 2 secondi.

Gli impianti collegati all'ASI non sono più alimentati.

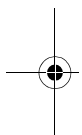

3.5 Utilizzo delle funzioni di controllo remoto dell'ASI

EX dispone, a scelta, di due dispositivi di controllo remoto.

▶ **RPO**: si tratta di una funzione di arresto remoto dell'ASI (**Remote Power Off**) che consente di mettere l'insieme delle apparecchiature collegate all'ASI mediante un contatto di utenza remoto.

Il riavvio dell'ASI richiede un intervento manuale.

▶ **ROO**: si tratta di una funzione di On/Off remoto dell'ASI (**Remote ON/OFF**) che consente di controllare il sistema premendo il pulsante (27) a livello remoto.

Queste funzioni si ottengono tramite l'apertura del contatto che si raccorda tra i pin del connettore a lato posteriore dell'ASI (cfr. figure di seguito).



Modello RT

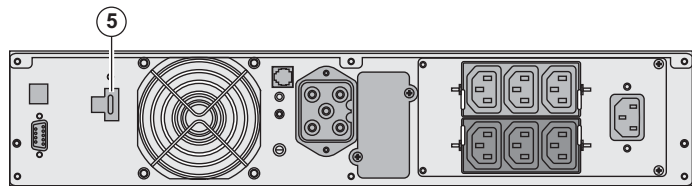

Modello Tower

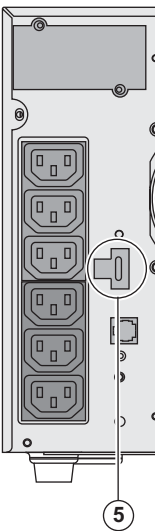

Collegamento e test dei comandi remoti



- 1 - Verificare che l'ASI sia in posizione di arresto e che la rete elettrica di alimentazione sia spenta.
- 2 - Rimuovere il connettore **(5)** svitando le viti.
- 3 - Collegare un contatto secco isolato, di tipo normalmente chiuso (60 Vdc / 30 Vac max., cavo pari a 0,75 mm²) tra i due pin del connettore **(5)**, cfr. figura.

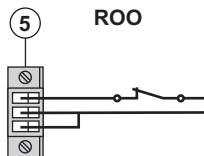

ROO

Contatto aperto: arresto dell'ASI.
Contatto chiuso: accensione dell'ASI (ASI collegato alla rete e rete elettrica di alimentazione accesa).

Nota: il comando On/Off locale tramite il pulsante **(27)** rimane sempre operativo anche in modalità comando remoto.

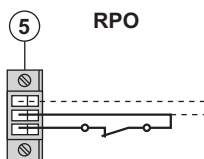

RPO

Contatto aperto: arresto dell'ASI.

Per ritornare in modalità di funzionamento normale, disattivare l'arresto remoto e riavviare l'ASI tramite il pulsante **(27)**.

- 4 - Inserire il connettore **(5)** nel suo alloggiamento sul lato posteriore dell'ASI.
- 5 - Collegare e riavviare l'ASI secondo le procedure descritte in precedenza.
- 6 - Attivare il contatto esterno di arresto remoto per testare la funzione.



Attenzione: questo connettore deve essere esclusivamente collegato a circuiti di livello T0 (tensione molto bassa)



4. Accesso alle misure e personalizzazione

4.1 Sinottico del display

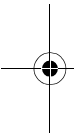
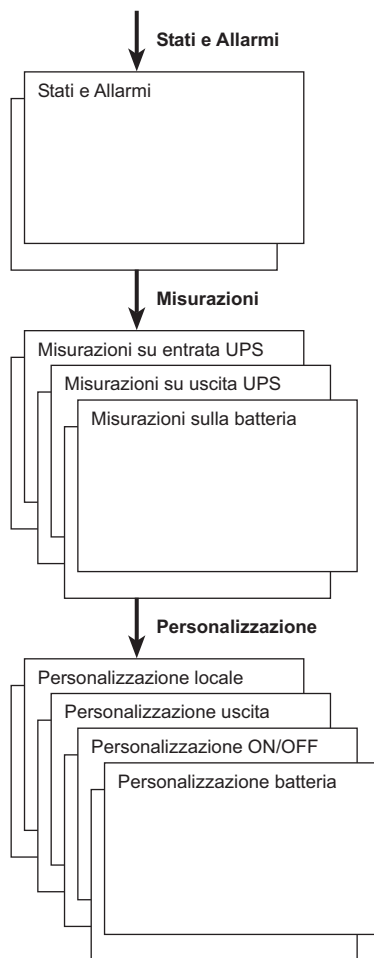

4.2 Accesso alle misure

Premendo ripetutamente il pulsante di scorrimento (25) è possibile accedere alle indicazioni di stati e allarmi, nonché alle misure di tensione, corrente, frequenza, potenza erogata e autonomia della batteria.

4.3 Personalizzazione tramite il pannello di comando

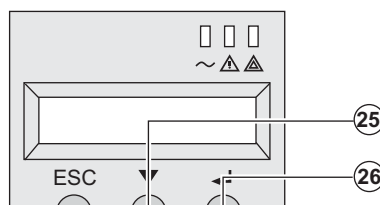

- Premere ripetutamente il pulsante di scorrimento (25) per accedere al menu di personalizzazione.
- Il pulsante di convalida (26) permette di accedere alle impostazioni.
- Infine, confermare l'impostazione effettuata premendo il pulsante di convalida (26).



4. Accesso alle misure e perso

Personalizzazione dell'uscita

| Funzione | Configurazione di fabbrica | Altre impostazioni | Comme |
|--|--|--|----------------------------------|
| Tensione di uscita ⁽¹⁾ | 230 Volt AC | 200/208/220/240/250 Volt AC | |
| Convertitore di frequenza ⁽¹⁾ | Disattivo | Attivo | Gli impia mai trasf |
| Frequenza di uscita ⁽¹⁾ | Selezione automatica | 50/60 Hz | Selezion unicame convertit |
| Trasferimento sulla rete elettrica AC By-pass ⁽¹⁾ | Se la rete elettrica AC By-pass rientra nella tolleranza | Se la rete elettrica AC By-pass è fuori tolleranza | |
| Livello di sovraccarico ⁽¹⁾ | 100% | 30 / 50 / 70% | Allarme della sog |

(1) Questi parametri possono essere modificati unicamente quando l'ASI è in posizione O
I commenti dettagliati sono disponibili nel software **Personal Solution-Pac**.

Personalizzazione Avvio/Arresto (ON/OFF)

| Funzione | Configurazione di fabbrica | Altre impostazioni | Commen |
|---|----------------------------|--------------------|---|
| Avviamento su batteria | Attivo | Disattivo | |
| Riavviamento automatico | Attivo | Disattivo | Riavviam al ritorno |
| Risparmio energetico | Disattivo | Attivo | Se la funz automatic batteria a |
| Rilevazione di inversione fase/neutro (SWF) | Disattivo | Attivo | Se la funz rilevazion neutro, l' OFF |

Personalizzazione batteria

| Funzione | Configurazione di fabbrica | Altre impostazioni | Commen |
|---|--|-------------------------------------|-----------------------|
| Test della batteria | Tutte le settimane | Nessun test / giornaliero / mensile | |
| Preallarme fine autonomia | 20% | Dallo 0 al 100% | Risoluzion |
| Impostazione dell'autonomia batteria | Rilevazione automatica del numero di moduli batteria | Da 13 a 200 Ah | |
| Protezione della batteria dalle scariche profonde | Attivo | Disattivo | Se la funz della q |





5. Manutenzione

5.1 Anomalie



Se la spia (21) o (22) è accesa, si è verificata una anomalia di funzionamento o è scattato un allarme. Utilizzare il pulsante di uscita/ritorno (24) per arrestare l'allarme acustico.

| | Sintomo | Diagnostica | Rimedio |
|---|--|---|---|
| 1 | L'ASI non si avvia, il display alfanumerica indica: COLD START NOK CHECK AC WIRING | Le rete elettrica è assente oppure è collegata all'uscita dell'ASI. | Verificare che l'ASI è correttamente collegata alla rete elettrica. |
| 2 | La spia (22) è accesa e la spia SWF (11) è accesa sulla parte posteriore dell'ASI. Il display alfanumerico indica: INV FASE/NEUTRO VERIF. COLLEG. | Inversione di fase della rete di alimentazione. L'ASI rimane all'arresto. | ►Per le reti elettriche trifase, verificare il cablaggio: scollegare la presa di rete di 18 A (SCHUKO) oppure chiamare un elettricista per modificare il cablaggio. ►Per qualsiasi altra anomalia, chiamare un elettricista per disattivare la rilevazione della fase. |
| 3 | La spia (22) è accesa, il display alfanumerica indica: NO BATTERIA VERIFICA COLLEGA | La batteria non è raccordata correttamente. | Verificare il collegamento della batteria (vedere §5.2, Sostituzione del modulo batteria). |
| 4 | La spia (22) è accesa, il display alfanumerica indica: GUASTO BATTERIE CHIAMA SERVICE | È stato rilevato un guasto alla batteria. | Procedere alla sostituzione della batteria (vedere §5.2, Sostituzione del modulo batteria). Rivolgersi al servizio clienti. |
| 5 | La spia (21) è accesa, il display alfanumerica indica: SOVRACCARICO RIDURRE CARICO | Il tasso di carico supera il livello di sovraccarico configurato o supera la capacità dell'ASI. | Verificare la potenza richiesta dagli impianti e sovraccaricare gli impianti non prioritari. Ridurre il livello di sovraccarico. |
| 6 | La spia (22) è accesa, il display alfanumerica indica: NON PROTETTO SOVRACC. USCITA | L'ASI è in sovraccarico. Gli impianti collegati sono alimentati direttamente dalla rete elettrica attraverso il by-pass. | Verificare la potenza richiesta dagli impianti e sovraccaricare gli impianti non prioritari. |
| 7 | La spia (22) è accesa, il display alfanumerica indica: RIDURRE CARICO RIPARTENZA UPS | In seguito a sovraccarichi ripetuti, l'ASI è bloccato in posizione by-pass. Gli impianti collegati sono alimentati direttamente dalla rete elettrica. | Verificare la potenza richiesta dagli impianti e sovraccaricare gli impianti non prioritari. Arrestare e riavviare l'ASI per ritornare al funzionamento normale. |
| 8 | La spia (22) è accesa, il display alfanumerica indica: DIF SOVRACCARICO RIDURRE CARICO | L'ASI si è arrestato automaticamente a causa di un grave sovraccarico. | Verificare la potenza richiesta dagli impianti e sovraccaricare gli impianti non prioritari. |
| 9 | La spia (22) è accesa, il display alfanumerica indica: C.C. CARICABATT VERIFICA COLLEGA | L'ASI si è arrestato automaticamente a causa di un cortocircuito in uscita dall'ASI. | Verificare l'impianto collegato dall'ASI (cablaggio e apparecchiatura). |





Anomalie su un ASI dotato di modulo HotSwap MBP



| | Sintomo | Diagnostica | Rimedio |
|----|---|---|---|
| 12 | Gli impianti collegati non sono alimentati quando il commutatore rotativo (49) del modulo HotSwap MBP si trova in posizione By-pass. | <ul style="list-style-type: none"> ▶ Gli impianti sono collegati in uscita dall'ASI anziché essere collegati al modulo HotSwap MBP. ▶ Il cavo della rete elettrica di alimentazione è collegato in entrata dell'ASI anziché essere collegato al modulo HotSwap MBP. | Verificare il cablaggio del modulo (§2.6). |
| 13 | Gli impianti collegati non sono alimentati quando il commutatore rotativo (49) del modulo HotSwap MBP si trova in posizione Normale. | <ul style="list-style-type: none"> ▶ L'ASI è all'arresto. ▶ Il cablaggio tra l'ASI e il modulo HotSwap MBP non è corretto. | <ul style="list-style-type: none"> ▶ Avviare l'ASI. ▶ Verificare il cablaggio del modulo (§2.6). |
| 14 | Gli impianti collegati non vengono alimentati in caso di interruzione della rete elettrica. | <ul style="list-style-type: none"> ▶ Il commutatore rotativo (49) del modulo HotSwap MBP si trova in posizione By-pass. ▶ Il cablaggio tra l'ASI e il modulo HotSwap MBP non è corretto. | <ul style="list-style-type: none"> ▶ Portare il commutatore (49) del modulo HotSwap MBP in posizione Normale. ▶ Verificare il cablaggio del modulo (§2.6). |

In caso di guasto tale da comportare l'arresto dell'ASI, premere il pulsante Avvio/Arresto (4) per riavviare l'ASI. In caso di guasto.

5.2 Sostituzione del modulo batteria

Richiamo sulle istruzioni di sicurezza:



La batteria presenta un rischio di elettrocuzione ed una corrente di cortocircuito elevata. Sugli elementi della batteria, occorre prendere le seguenti precauzioni:

- ▶ Togliere orologi, anelli, fedi, braccialetti o qualsiasi altro oggetto metallico,
- ▶ Utilizzare utensili con impugnatura isolata.

Smontaggio del modulo batteria

Modello RT

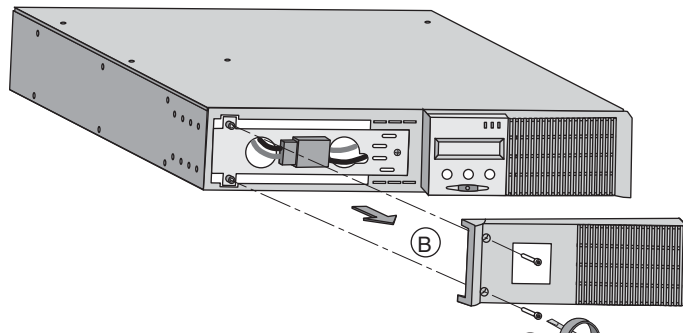

A - Svitare la se...
anteriore fissata...
B - Rimuovere c...



5. Manutenzione

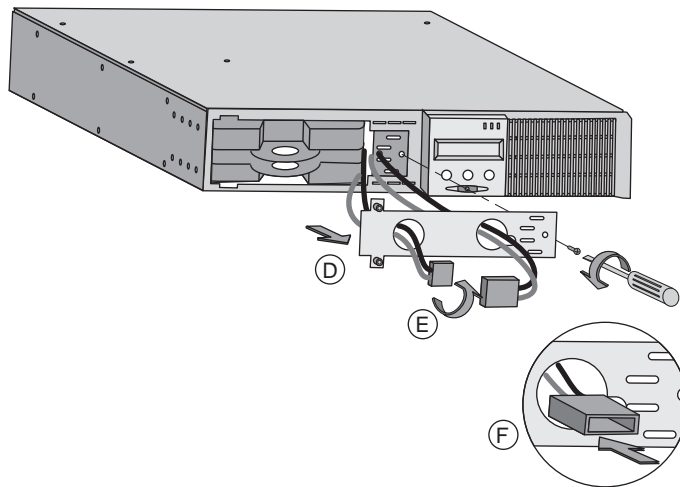

D - Rimuovere il coperchio della protezione della batteria.
E - Far ruotare il coperchio.
F - Passare il connettore nell'orifizio.

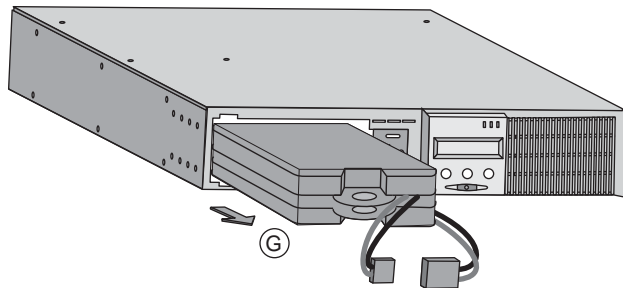

G - Estrarre il gruppo batteria. Rimuovere la linguetta di plastica e procedere alla sostituzione.

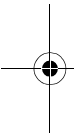

Modello Tower

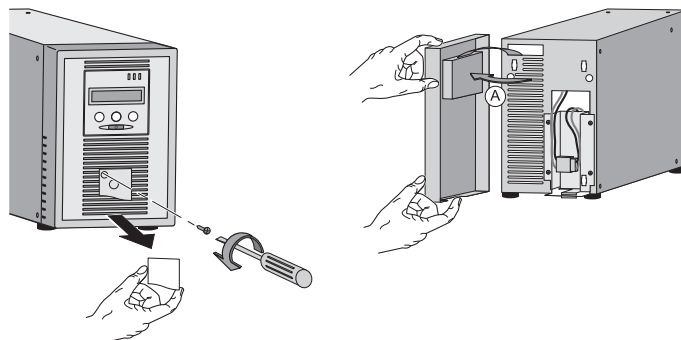

A - Rimuovere il lato anteriore del server e posizionarlo a lato dell'unità.

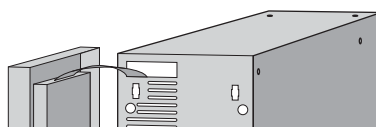

B - Scollegare il gruppo batteria dal server separando i 2 connettori. Assicurarsi di tirare i connettori con forza.



5. M

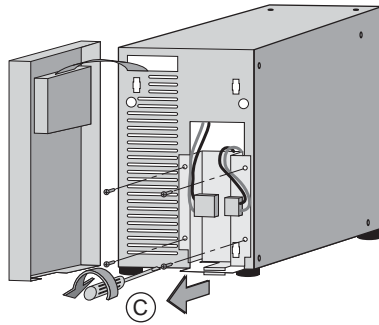

C - Rimuovere il coperchio metallico.

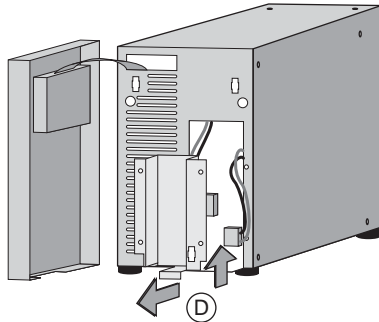

D - Rimuovere la batteria.

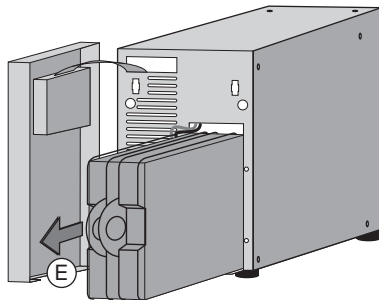

E - Estrarre la linguetta di plastica per la sostituzione.

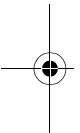

Rimontaggio del nuovo modulo batteria

Ripetere le operazioni sopra descritte in senso inverso.



►Per preservare la sicurezza e lo stesso livello di performance, utilizzare elementi batteria
►Fare attenzione ad inserire correttamente i componenti maschio e femmina del connettore.



5. Manutenzione

5.3 Manutenzione di un ASI dotato di modulo HotSwap MBP

Modello RT

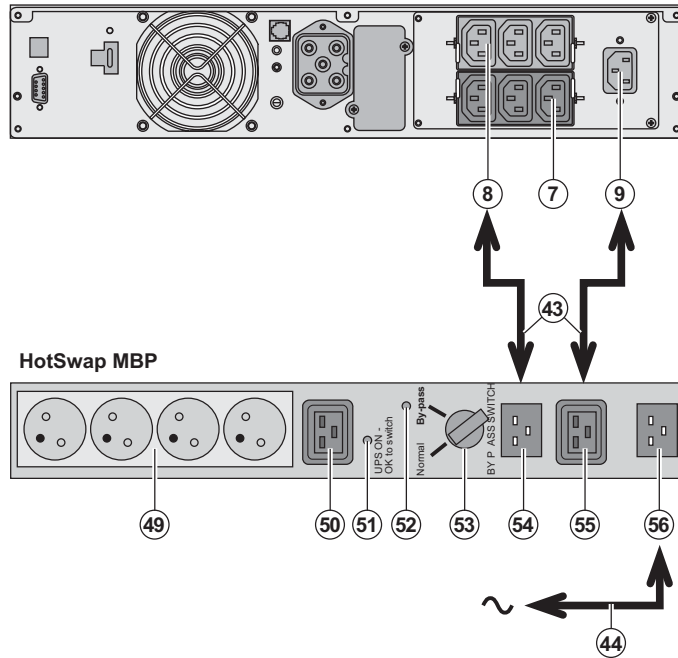

La funzione del modulo HotSwap MBP è quella di consentire la manutenzione dell'ASI, eventualmente la sostituzione del modulo HotSwap MBP, senza interferire sull'alimentazione elettrica delle apparecchiature (funzione **HotSwap**).

Manutenzione:

1 - Portare il commutatore di posizione By-pass: la spia del modulo **HotSwap MBP** si accende a segnalare che gli impianti possono essere alimentati direttamente dalla rete e il modulo **HotSwap MBP** può essere sostituito.
2 - Arrestare l'ASI premendo il pulsante Avvio/Arresto (27) sulla piastrina dell'ASI: la spia (51) "UPS OK switch" si spegne e a questo punto il modulo può essere scollegato e sostituito.

Ritorno al funzionamento:

1 - Verificare che l'ASI sia correttamente collegato al modulo HotSwap MBP.
2 - Avviare l'ASI premendo il pulsante Avvio/Arresto (27) sulla piastrina dell'ASI: la spia (51) "UPS OK switch" si accende sul modulo **HotSwap MBP** (in caso contrario segnalare errore di raccordo del modulo **HotSwap MBP** all'ASI).

3 - Portare il commutatore di posizione Normale: la spia del modulo **HotSwap MBP** si spegne.
4 - Le apparecchiature sono protette dall'ASI.

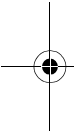



5.4 Centro di formazione



Per tenere sotto controllo l'impianto EATON ed intervenire al primo livello, viene da noi per i nostri clienti un programma completo di formazione tecnica in lingua inglese e in lingua francese.

For further information, please visit our website: www.eaton.com

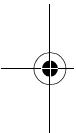



6. Allegati

6.1 Specifiche tecniche

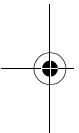
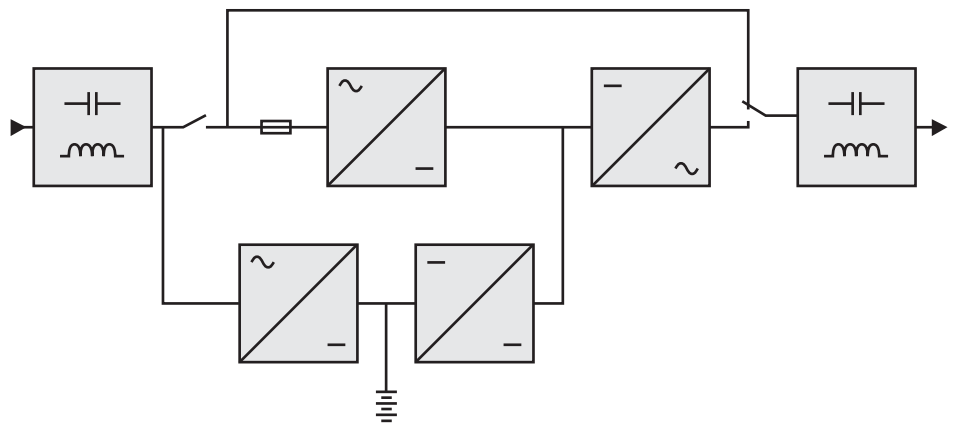

| | EX 700 | EX 1000 EX 1000 RT | EX 1500 EX 1500 RT |
|--|--|---|---|
| Potenza di uscita | 700 VA / 630 W | 1000 VA / 900 W ⁽³⁾ | 1500 VA / 1350 W ⁽⁴⁾ |
| Rete elettrica di alimentazione | Monofase da 100 / 120 / 140 / 160 a 284 V ⁽³⁾ 50/60 Hz (selezione automatica) > 0,95 | | |
| Uscita utenza | Monofase 230 V $\pm 3\%$ ⁽⁵⁾ 50/60 Hz $\pm 0,5\%$ ⁽⁶⁾ < 4% su carico lineare, < 6% su carico non lineare 102% permanente, 130% 12s, > 130% 2s | | |
| Corrente | 3 A ⁽⁸⁾ | 4,3 A ⁽⁸⁾ | 6,5 A ⁽⁸⁾ |
| Batteria | 6x12 V - 7 Ah, al piombo, a tenuta ermetica, senza manutenzione | 3x12 V - 7 Ah, al piombo, a tenuta ermetica, senza manutenzione | 3x12 V - 9 Ah, al piombo, a tenuta ermetica, senza manutenzione |
| Ambiente | <ul style="list-style-type: none"> ► Soglia di rumore < 38 dBA ► Temperatura di funzionamento 0°C a 40°C ► Umidità 20% to 90% (senza condensazione) ► Corrente di fuga < 1,1 mA ► Temperatura di stoccaggio -25°C a 40°C ► Altitudine 1000 m | | |
| Norme e omologazioni | IEC/EN 62040-1-1, EN 60950-1 (RD) IEC/EN 62040-3 EN 50091-2/IEC 62040-2 class B, IEC 61000-4-2/-3/-4/-6-8/-11, IEC 61000-3-2/-3 | | |



6.2 Glossario

| | |
|---|--|
| AC By-pass | Via derivata dalla rete elettrica di alimentazione, comandata da l'alimentazione diretta degli impianti mediante la rete elettrica in caso di malfunzionamento dell'ASI. |
| AC Normale | Si tratta della normale rete elettrica di alimentazione dell'ASI. |
| ASI | Alimentazione Senza Interruzione |
| Autonomia | Periodo di tempo durante il quale gli impianti vengono alimentati dalla batteria. |
| Avviamento su batteria | Rende possibile la messa sotto tensione degli impianti collegati alla rete elettrica di alimentazione. In tal caso l'ASI funziona a batteria. |
| Avvio/Arresto ASI mediante software | Permette di autorizzare o impedire al software di protezione di attivare o disattivare l'attivazione delle sequenze di Avvio/Arresto dell'ASI. |
| Convertitore di frequenza | Funzione che permette di convertire la frequenza della rete elettrica di alimentazione dell'ASI (50 Hz -> 60 Hz o 60 Hz -> 50 Hz). |
| FlexPDU | Modulo di prese di uscita ASI per l'installazione a pannello. Esistono diversi moduli, a seconda dei diversi tipi di prese. |
| HotSwap MBP | Modulo di derivazione manuale dell'ASI per consentirne la manutenzione di diverse tipologie di moduli, a seconda dei diversi tipi di prese. |
| Impianti | Apparecchi o dispositivi raccordati in uscita dall'ASI. |
| Percentuale di caricamento | Rapporto tra la potenza assorbita dagli impianti collegati all'ASI e la potenza erogabile dall'ASI. |
| Personalizzazione | Programmazione di alcuni parametri diversa dalla configurazione standard. Alcune funzioni dell'ASI possono essere modificate mediante il software Solution-Pac al fine di soddisfare meglio le necessità dell'utente. |
| Prese programmabili | Prese che possono essere disinserite automaticamente durante l'operazione di temporizzazione di apertura programmabile mediante il software. L'ASI è dotato di 2 gruppi di 2 prese programmabili. |
| Scarica profonda | Livello di scarica della batteria oltre il minimo consentito, tale da risultare irreversibile alla batteria. |
| Soglia di preallarme per fine autonomia della batteria | Si tratta di un valore minimo del livello di tensione della batteria che indica la fine imminente dell'autonomia della batteria ed assumere le misure previste in caso di interruzione di corrente agli impianti. |
| Test della batteria | Test interno dell'ASI che permette di verificare lo stato della batteria. |

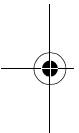

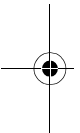



www.eaton.com

EX
700 - 1000
1000 RT -
EXB 1000
EXB 1000

**Manual d'
emploi**

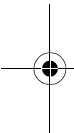

Pulsar Series

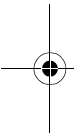



Les agradecemos que hayan optado por un producto EATON para la seguridad de sus ap

La gama **EX** ha sido elaborada con el mayor esmero.

Para explotar al máximo las altas prestaciones de su **SAI (Sistema de Alimentación Ininterrumpida)**, que se tomen el tiempo necesario para leer este manual.

Antes de la instalación de **EX**, leerse el cuaderno con las instrucciones de seguridad a seguir y las instrucciones del presente manual.

Les invitamos a que descubran la oferta de EATON así como las opciones de la gama **EX** visitando www.eaton.com, o poniéndose en contacto con su representante EATON.

Respeto medioambiental

La sociedad EATON se ha comprometido en aplicar una política de protección y preservación del medio ambiente. Nuestros productos han sido desarrollados siguiendo una estrategia de ecodiseño.

Sustancias

Este producto no contiene ni CFC, ni HCFC, ni amianto.

Embalaje

Para mejorar el tratamiento de los vertidos y facilitar el reciclaje, separen los elementos de

- ▶ La caja de cartón está hecha con más de un 50% de cartón reciclado.
- ▶ Las bolsas y las bolsitas son de polietileno.
- ▶ Los materiales que forman el embalaje son reciclables y están marcados con el símbolo

| Materiales | Abreviatura | Número en el símbolo |
|------------------------------|-------------|----------------------|
| Polietileno Teraftalate | PET | 01 |
| Polietileno de Alta Densidad | HDPE | 02 |
| Polivinilo de Cloruro | PVC | 03 |
| Polietileno de Baja Densidad | LDPE | 04 |
| Polipropileno | PP | 05 |
| Poliestireno | PS | 06 |

Cumplir con las normativas locales vigentes para la eliminación del embalaje.

Final de vida útil

La sociedad EATON se ha comprometido en tratar los productos al final de su vida útil de acuerdo con las normativas locales.

EATON trabaja con empresas encargadas de la recogida y eliminación de nuestros productos.

Producto

El producto está hecho con materiales reciclables.

Su desmantelamiento y destrucción tendrán que realizarse conforme a lo dispuesto en las normativas vigentes relativas a los vertidos.

El producto, al final de su vida útil, tendrá que ser depositado en un centro de tratamiento de residuos electrónicos.

Batería

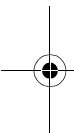



Introducción

Pictogramas utilizados



Instrucciones a seguir obligatoriamente



Informaciones, consejos, ayuda.



Indicación visual de obligatoria observancia



Operación a realizar.



Señalización acústica.

Los símbolos convencionales adoptados para representar los indicadores luminosos en las ilustraciones siguientes:



Indicador luminoso apagado.



Indicador luminoso encendido.



Indicador luminoso parpadeando.

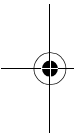



1. Presentación

1.1 Posiciones estándar

Posición torre

Posición rack

1.2 Caras traseras

EX 700 / 1000 / 1500

EX 1000 RT / 1500 RT

EX EXB (módulo batería opcional)

EX EXB RT (módulo batería opcional)

1.3 Panel de visualización y de mando

2. Instalación

2.1 Desembalaje y comprobación del contenido

2.2 Instalación del modelo RT en posición de torre

2.3 Instalación del modelo RT en un rack

2.4 Puertos de comunicación

Conexión del puerto de comunicación RS232 o USB (facultativo)

Instalación de las tarjetas de comunicación (opcional)

2.5 Características del puerto de comunicación por contactos

2.6 Conexiones a un módulo FlexPDU (Power Distribution Unit)

2.7 Conexiones a un módulo HotSwap MBP

Funcionamiento del módulo HotSwap

2.8 Conexiones de un SAI sin módulo FlexPDU o HotSwap MBP

3. Utilización

3.1 Puesta en servicio y en funcionamiento normal

3.2 Funcionamiento con batería

3.3 Vuelta de la corriente eléctrica

3.4 Parada del SAI

3.5 Utilización de las funciones de mando a distancia del SAI

4. Personalización y acceso a las medidas

4.1 Descripción sinóptica del visualizador

4.2 Acceso a las medidas

4.3 Personalización mediante el panel de mando

4.4 Personalización mediante el software externo

5. Mantenimiento

5.1 Anomalías

Anomalías en un SAI equipado con un módulo HotSwap MBP

5.2 Sustitución del módulo de la batería

Recordatorio de las instrucciones de seguridad

Desmontaje del módulo de batería

Montaje del nuevo módulo de batería

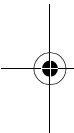



1. Presentación

1.1 Posiciones estándar

Posición de torre

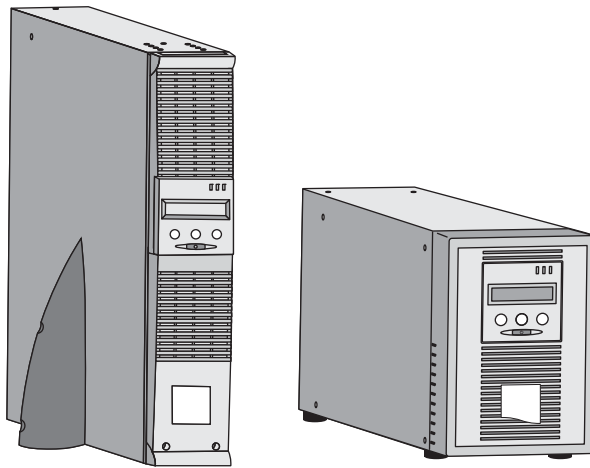

| Cuadro de dimensiones en mm | |
|-----------------------------|---|
| EX 700 | 2 |
| EX 1000 | 2 |
| EX 1000 RT | 8 |
| EX 1500 | 2 |
| EX 1500 RT | 8 |
| EX EXB | 2 |
| EX EXB RT | 8 |

| Cuadro de masas en kg | |
|-----------------------|---|
| EX 700 | 1 |
| EX 1000 | 1 |
| EX 1000 RT | 1 |
| EX 1500 | 1 |
| EX 1500 RT | 2 |
| EX EXB | 2 |
| EX EXB RT | 2 |

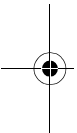

Posición de rack

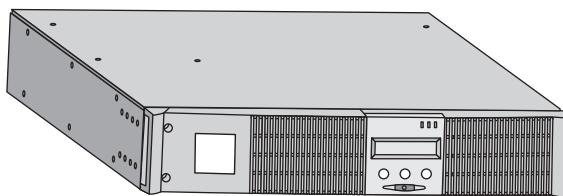



1.

1.2 Caras traseras

EX 700 / 1000 / 1500

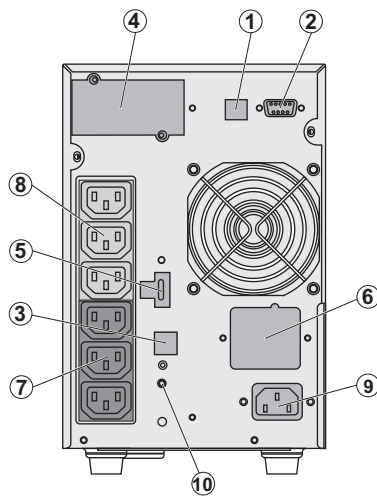

- (1) Puerto de co
- (2) Puerto de co
- (3) Conector de
- automático de u
- (excepto EX 700
- (4) Emplazamie
- comunicación o
- (5) Conector pa
- mando a distan
- una parada de e
- (6) Conector pa
- módulo de bate
- (7) Grupos de 3
- la conexión de
- (8) Grupo de 3 t
- los equipos
- (9) Toma para la
- de alimentación
- (10) Indicador lu
- inversión fase/r
- (SWF)

EX 1000 RT / 1500 RT

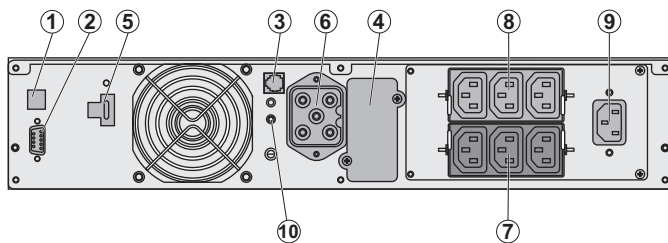
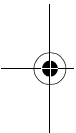

EX EXB (módulo de batería opcional)

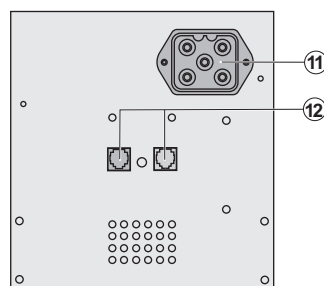

- (11) Conectores
- módulos de bat
- los otros módul
- (12) Conectores
- automático de l



1. Presentación

EX EXB RT (módulo de batería opcional)

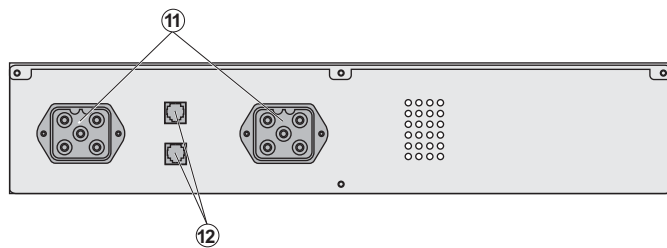

1.3 Panel de visualización y de mando

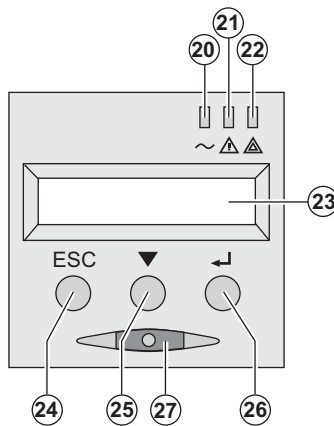

- (20) Indicador luminoso protegidos
- (21) Indicador luminoso funcionamiento degradado
- (22) Indicador luminoso protegidos
- (23) Pantalla de visualización
- (24) Botón de salir y de volver
- (25) Botón de desplazamiento
- (26) Botón de validación
- (27) Botón de control Manual (ON/OFF) del SAI y de las ton

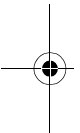



2.1 Desembalaje y comprobación del contenido

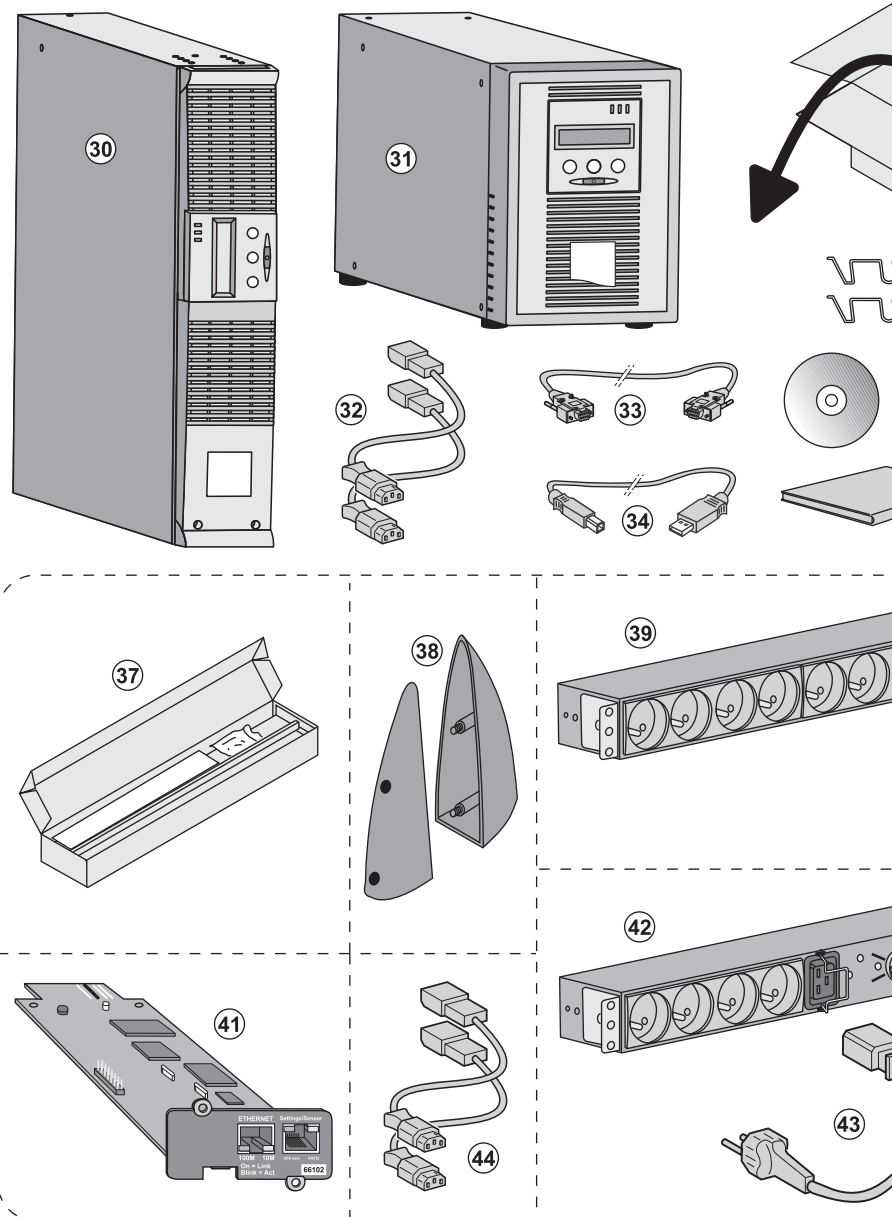

(30) EX 700, 1000, 1500.

(31) EX 1000 RT, 1500 RT.

(32) 2 cordones para conectar los equipos.

(33) Cable de comunicación RS232.

(34) Cable de comunicación USB.

(35) Sistema de bloqueo de los cables de alimentación de los equipamientos (modelo RT

Elementos suministrados según opcionalmente:

(37) Kit de montaje en armario

(38) 2 Pies de mantenimiento en RT únicamente).

(39) Módulo **FlexPDU** (opcional

(40) Cordón de conexión del



2. Instalación

2.2 Instalación del modelo RT en posición de torre

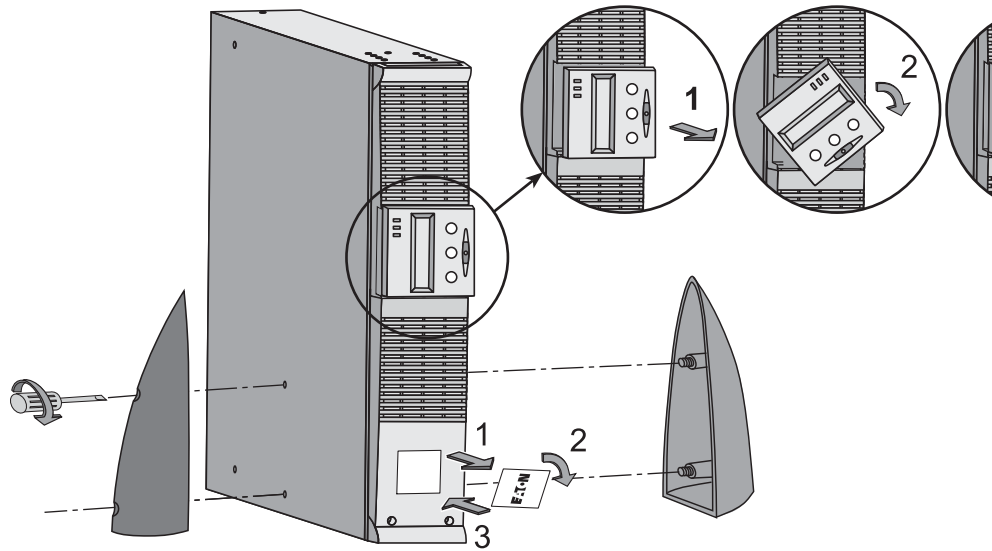

2.3 Instalación del modelo RT en un rack

Se recomienda instalar el o los módulos de batería EXB lo más bajo posible en el rack, y colocar e

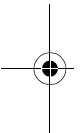

Seguir las etapas 1 a 4 para el montaje del módulo sobre sus rieles.

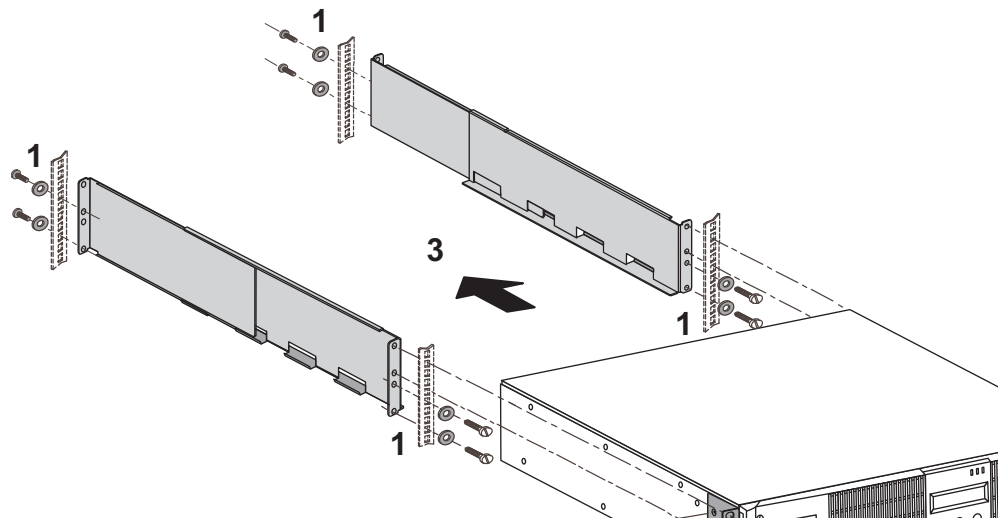



2.4 Puertos de comunicación

Conexión del puerto de comunicación RS232 o USB (facultativo)



El puerto de comunicación RS232 y el puerto de comunicación USB no pueden funcionar al mismo tiempo.

Modelo Torre

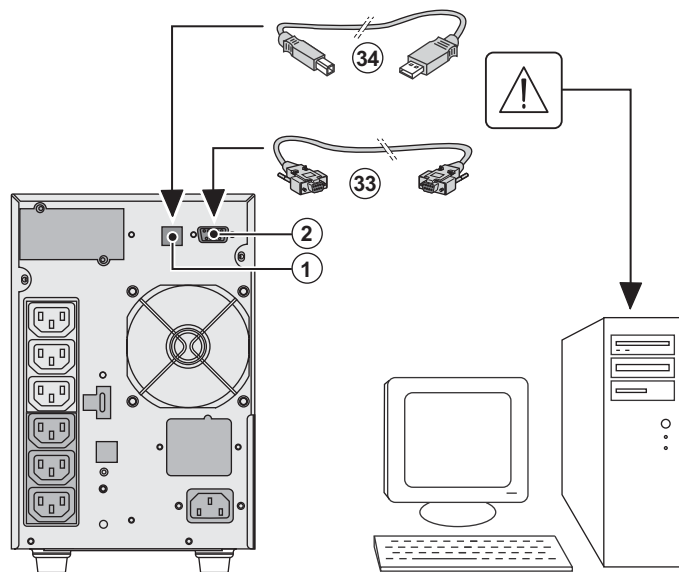

1 - Conectar el cable de comunicación RS232 (33) o USB (34) del equipo informático.

2 - Conectar la consola de comunicación RS232 o el cable de comunicación USB.

El SAI ya podrá administrar la configuración de seguridad de la consola de administración.

Modelo RT

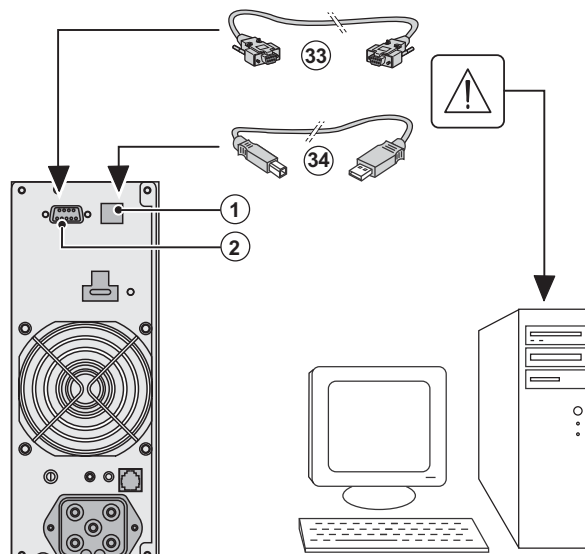



2. Instalación

Instalación de las tarjetas de comunicación (opcionales)

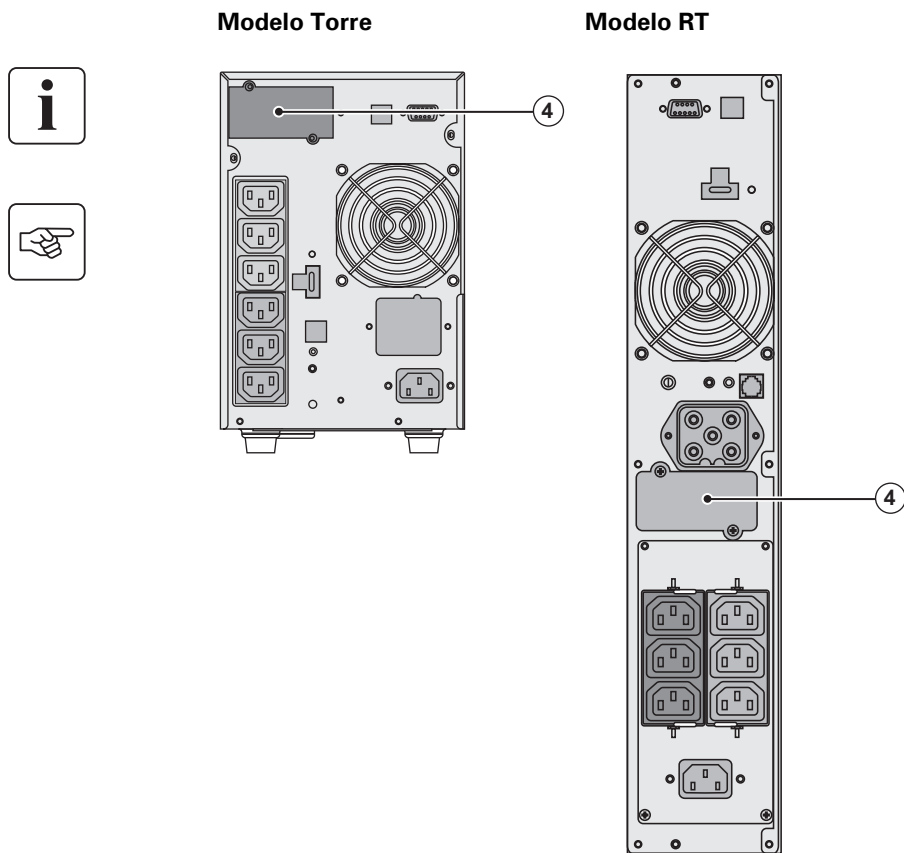

No será necesario para
instalar la tarjeta de com
(4): Emplazamiento de la
comunicacion, con acces

- 1 - Quitar la placa protec
fijada con tornillos.
- 2 - Insertar la tarjeta de co
emplazamiento previsto.
- 3 - Fijar la placa protector
los tornillos.

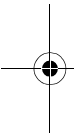

2.5 Características del puerto de comunicación por contactos (2)

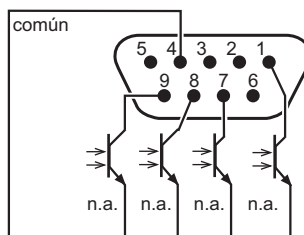

- ▶Clavija 2, 3, 5 y 6 : no se utiliza,
- ▶Clavija 1 : funcionamiento con Bypass automático
- ▶Clavija 4 : común usuario,
- ▶Clavija 7 : prealarma de fin de autonomía de la ba
- ▶Clavija 8 : aplicaciones de usuario protegidas,
- ▶Clavija 9 : funcionamiento con batería,

n.a.: contacto normalmente abierto

Cuando una información está activa, el contacto se mantiene cerrado entre la clavija común 4 y la información correspondiente.

Características de los contactos (optocopladores)

- ▶Tensión: 48 VCC máximo,
- ▶Corriente: 25 mA máximo,
- ▶Potencia: 1,2 W.



2.6 Conexión al módulo FlexPDU (Power Distribution Unit) (Opcional)

Modelo RT

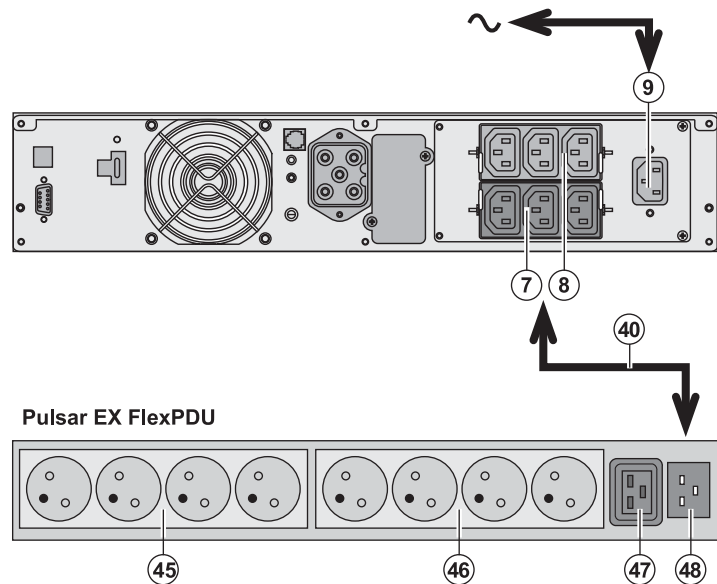

1 - Conectar la toma de corriente a la red eléctrica de alimentación de

2 - Conectar la toma de corriente eléctrica del módulo a la toma de salida del cordón (40). Este cable y este terminal son de color rojo.

3 - Conectar los terminales (46) et (47) del módulo a las tomas de corriente de la versión del módulo.

4 - Fijar los cables a las bridas metálicas.

2.7 Conexiones a un módulo HotSwap MBP (Opcional)

La función del módulo **HotSwap MBP** es permitir el mantenimiento y, eventualmente, la actualización de los equipos conectados (función **HotSwap**).

Modelo RT

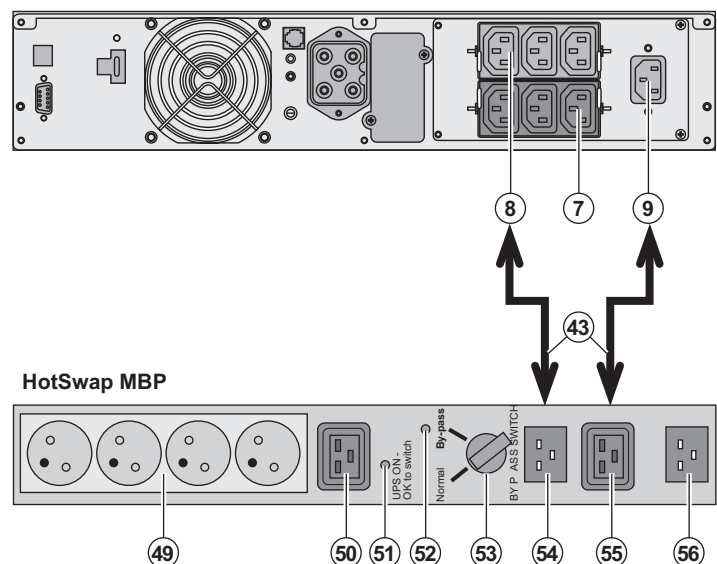

1 - Conectar la toma de corriente al módulo **HotSwap MBP** por medio del cordón.

2 - Conectar la toma de corriente eléctrica del SA a la toma (55) del módulo **HotSwap MBP**. Este cable y estas tomas están marcadas con un color rojo.

3 - Conectar una toma de corriente a la toma "UPS" del módulo **HotSwap MBP**, suministrado. Estas tomas están marcadas con un color rojo. Es necesario utilizar el cable FR/DIN del módulo (68439) para alimentarlo y conectarlo a la red eléctrica. En el caso de un módulo de red eléctrica de alimentación, utilizar el kit de

2. Instalación

Funcionamiento del módulo HotSwap MBP

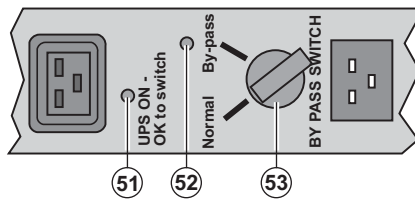

El módulo **HotSwap MBP** incluye un conmutador rotativo (53).
Normal: los equipos están alimentados por el SAI.
Bypass: los equipos están alimentados por la red eléctrica.

Puesta en servicio del SAI con el módulo HotSwap MBP:

- 1 - Comprobar que el SAI esté correctamente conectado al módulo **HotSwap MBP**.
 - 2 - Colocar el conmutador (53) en posición Normal.
 - 3 - Poner en marcha el SAI pulsando el botón Marcha/Parada (27) en la cara delantera del SAI.
- Los equipos están siendo alimentados ya por el SAI.
 El indicador luminoso (51) "UPS ON - OK to switch" se enciende en el módulo **HotSwap MBP**.

Test del módulo HotSwap MBP

- 1 - Colocar el conmutador (53) en posición Bypass y comprobar que los equipos sigan estando alimentados.
- 2 - Volver a poner el conmutador (53) en posición Normal.

2.8 Conexión de un SAI sin módulo FlexPDU o HotSwap MBP



Comprobar que las indicaciones señaladas en la placa de identificación situada en la parte trasera del SAI correspondan a la red eléctrica de alimentación y al consumo eléctrico real de los equipos.

Modelo Torre

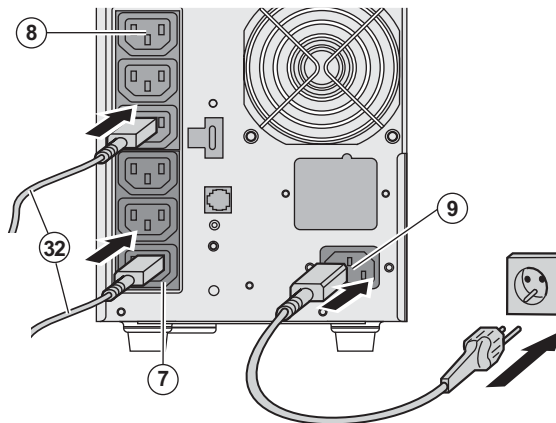

- 1 - Conectar la toma de alimentación del SAI a la red eléctrica con el cable de alimentación del equipo.
 - 2 - Conectar los equipos de los cordones (32).
- Conectar, preferentemente, los cables prioritarios a las 4 tomas prioritarias y los no prioritarios a las 4 tomas no prioritarias programables por pares.

Para controlar o programar el SAI, utilizar uno de los software de gestión de energía EATON.

Modelo RT

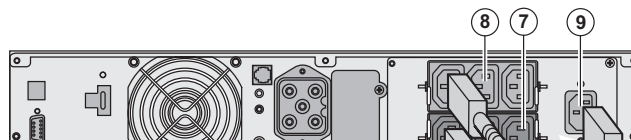



3.1 Puesta en servicio y en funcionamiento normal



En el momento del primer arranque, la presencia de la corriente eléctrica es imprescindible para evitar un error de cableado. Después, el aparato podrá arrancar estando ausente la corriente eléctrica.

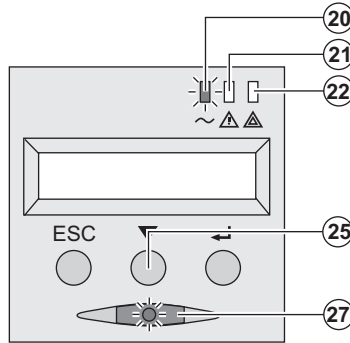

EX el botón (27) durante aproximadamente 10 segundos.

- ▶ El buzzer o zumbador emite un bip y todos los indicadores luminosos se encienden simultáneamente.
- ▶ A continuación, el buzzer emite 2 bips durante 10 segundos. El botón (27) sigue encendido, indicando la alimentación de la salida.



Los equipos conectados están siendo alimentados por la batería.

- ▶ El indicador luminoso (20) está encendido.
- ▶ Si el indicador luminoso (22) está encendido, indica un error de cableado (ver capítulo "Anomalías").

- ▶ En modo de funcionamiento normal, el botón (25) permite leer las medidas realizadas en las redes eléctricas AC Normal y AC Bypass, la capacidad de la batería y número de serie.

Personalización del SAI



Si se tiene previsto proceder a una personalización específica del SAI, se recomienda realizar la personalización del SAI al llegar a esta fase.

Este modo es accesible a través de los botones del panel de mando o con el software **Personalización** de Windows incluido en el CD-ROM **Solution-Pac** de Eaton.

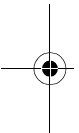

3.2 Funcionamiento con batería

Cambio a batería

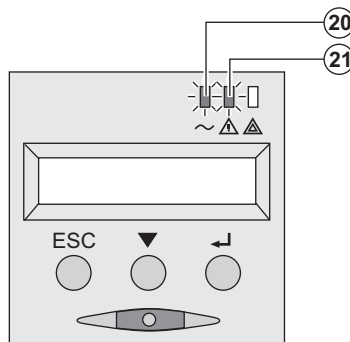

- ▶ Los equipos conectados siguen siendo alimentados por la red eléctrica cuando la red eléctrica ya no está disponible.
- ▶ Los indicadores luminosos (20) y (21) están encendidos.
- ▶ La alarma acústica emite un bip cada 10 segundos.

Los equipos conectados están siendo alimentados por la batería.

El visualizador indica la autonomía restante.

Umbral de prealarma de final de autonomía de la batería

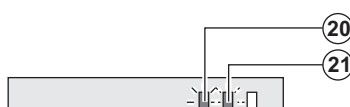

- ▶ Los indicadores luminosos (20) y (21) están encendidos.
- ▶ La alarma acústica emite un bip cada 3 segundos.



3. Utilización

Final de autonomía de la batería



- ▶ Todos los indicadores luminosos están apagados.
- ▶ La alarma acústica está en silencio.



El SAI está completamente parado.

3.3 Vuelta de la corriente eléctrica

Tras el corte, el SAI vuelve a arrancar automáticamente cuando vuelve la corriente eléctrica (a menos que la función haya sido desactivada mediante la personalización del SAI) y los equipos vuelven a recibir energía.

3.4 Parada del SAI

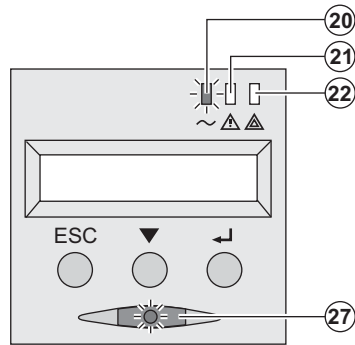

Presionar el botón (27) durante más de 2 segundos.

Los equipos conectados al SAI ya no están siendo alimentados.

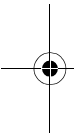

3.5 Utilización de las funciones de mando a distancia del SAI

EX dispone de dos dispositivos de mando a distancia a elegir.

▶ **RPO:** es una función de parada a distancia del SAI (**Remote Power Off**) que permite dejar sin tensión los equipos conectados al SAI a través de un contacto remoto de usuario.

El arranque del SAI requiere una intervención manual.

▶ **ROO:** es una función de marcha/parada a distancia del SAI (**Remote ON/OFF**) que permite accionar el SAI de forma remota.

Estas funciones se obtienen abriendo el contacto que se conecta entre las patillas adecuadas del SAI en la cara trasera del SAI (ver figuras siguientes).



Modelo RT

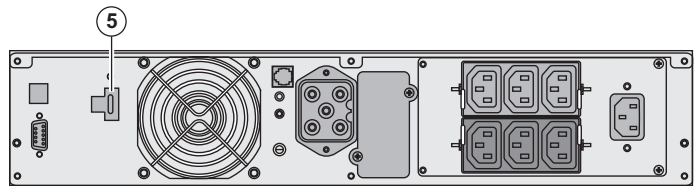

Modelo Tour

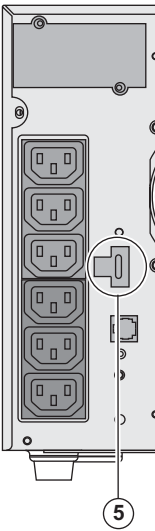

Conexión y test de los mandos a distancia



- 1 - Verificar que el SAI está en posición de parada y que la red eléctrica de alimentación es correcta.
- 2 - Retirar el conector (5) desatornillando los tornillos.
- 3 - Conectar un contacto seco aislado, del tipo normalmente cerrado (60 Vdc / 30 Vac máximo, cable de 0,75 mm²) entre ambas patillas del conector (5), ver figura.

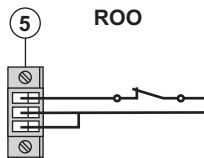

ROO
 Contacto abierto: parada del SAI
 Contacto cerrado: puesta en marcha del SAI (SAI conectado a la red eléctrica)
Nota: el mando Marcha/Parada local con el botón (27) sigue siendo válido para el mando a distancia.

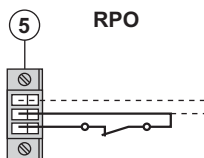

RPO
 Contacto abierto: parada del SAI
 Contacto cerrado: puesta en marcha del SAI (SAI conectado a la red eléctrica)
 Para volver a funcionamiento normal, desactivar el contacto externo y volver a arrancar el SAI con el botón (27).

- 4 - Enganchar el conector (5) en su emplazamiento en la cara trasera del SAI.
- 5 - Conectar y volver a arrancar el SAI según los procedimientos descritos anteriormente.
- 6 - Activar el contacto externo de parada a distancia para testar la función.



Atención: este conector debe ser exclusivamente conectado a circuitos de nivel TBTS (Módulo de Seguridad).



4. Acceso a las medidas y personalización

4.1 Descripción sinóptica del visualizador

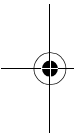
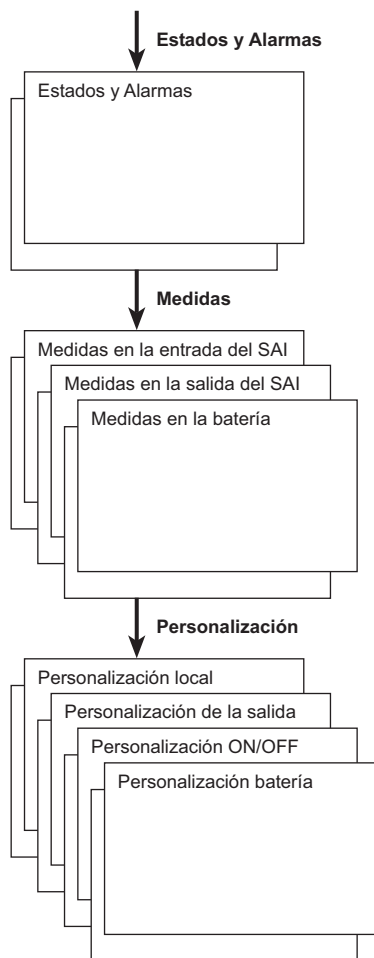

4.2 Acceso a las medidas

Pulsando sucesivamente el botón de desplazamiento (25) se accede a los estados y alarmas eventuales y a las medidas de tensión, corriente, frecuencia, potencia suministrada y autonomía de la batería.

4.3 Personalización con el panel de mando

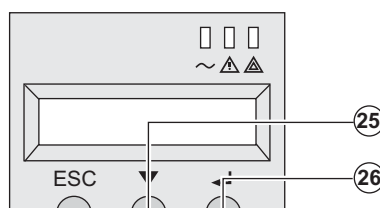

- Presionar sucesivamente el botón de desplazamiento (25) para acceder al menú de personalización.
- El botón de validación (26) permite acceder a las opciones a elegir.
- Por último, confirmar la opción elegida presionando el botón de validación (26).



4. Acceso a las medidas y pe

Personalización de la salida

| Función | Personalización de fábrica | Otras opciones a elegir | Coment |
|---|--|---|------------------------------------|
| Tensión de salida ⁽¹⁾ | 230 Voltios AC | 200/208/220/240/250 Voltios AC | |
| Convertidor de frecuencia ⁽¹⁾ | Inactiva | Activa | Los equip transferi |
| Frecuencia de salida ⁽¹⁾ | Selección automática | 50/60 Hz | Selección solamen convertid activa |
| Transferencia a red eléctrica AC By-pass ⁽¹⁾ | Si la red eléctrica AC By-pass está dentro de tolerancia | Si la red eléctrica AC By-pass está fuera de tolerancia | |
| Nivel de sobrecarga ⁽¹⁾ | 100% | 30 / 50 / 70% | Alarma e umbral |

(1) Estos parámetros únicamente son modificables cuando el **SAI** está en posición OFF. Los comentarios detallados están disponibles en el software **Personal Solution-Pac**.

Personalización Marcha/Parada (ON/OFF)

| Función | Personalización de fábrica | Otras opciones a elegir | Comenta |
|--|----------------------------|-------------------------|---|
| Arranque con batería | Activa | Inactiva | |
| Rearranque automático | Activa | Inactiva | Rearranque vuelta de |
| Ahorro de energía | Inactiva | Activa | Si función automática batería al potencia |
| Detección de inversión fase/neutro (SWF) | Inactiva | Activa | Si función posición de invers |

Personalización de la batería

| Función | Personalización de fábrica | Otras opciones a elegir | Comenta |
|---|---|--------------------------------|---------------------|
| Test de la batería | Cada semana | Ningún test / diario / mensual | |
| Prealarma de final de autonomía | 20% | 0 al 100% | Resolución |
| Elección de las autonomías de la batería | Detección automática del número de módulos de batería | De 13 a 200 Ah | |
| Protección de la batería contra las descargas | Activa | Inactiva | Si función garantía |





5. Mantenimiento

5.1 Anomalías



Si el indicador luminoso (21) o (22) está encendido, es que existe una anomalía de funcionamiento. Utilizar el botón de salir y de volver atrás (24) para parar la alarma acústica.

| | Síntoma | Diagnóstico | Corrección |
|---|--|--|---|
| 1 | El SAI no arranca, la pantalla de visualización alfanumérica indica: COLD START NOK CHECK AC WIRING | La red eléctrica está ausente o conectada a la salida del SAI. | Verificar que el SAI esté conectado correctamente a la red eléctrica. |
| 2 | El indicador luminoso (22) está encendido, y el indicador luminoso SWF (11) está encendido en la cara trasera del SAI. La pantalla de visualización alfanumérica indica: INV FASE/NEUTRO VERIF CONEXION | Inversión de fase de la red de alimentación. El SAI sigue parado. | ►En las redes eléctricas con neutro a tierra, para el cableado: desenchufar la toma de red 180° (SCHUKO), o llamar al electricista para la correcta conexión. ►Para cualquier otro caso, desactivar la detección de inversión de fase. |
| 3 | El indicador luminoso (22) está encendido, la pantalla de visualización alfanumérica indica: SIN BATERIA CONTROL CONEXION | La batería está conectada de forma incorrecta. | Comprobar la conexión de la batería (ver §5.2, módulo de batería). |
| 4 | El indicador luminoso (22) está encendido, la pantalla de visualización alfanumérica indica: DEF BATERIA CONTACTAR SAT | Se ha comprobado un fallo en la batería. | Proceder a la sustitución de la batería (ver §5.2, módulo de batería). Ponerse en contacto con el servicio postventa. |
| 5 | El indicador luminoso (21) está encendido, la pantalla de visualización alfanumérica indica: SOBRECARG SALIDA REDUCIR CARGA | La tasa de carga supera el nivel de sobrecarga configurado, o supera la capacidad del SAI. | Comprobar la potencia requerida por los equipos conectados y desconectar los equipos que no sean prioritarios. Reducir la carga de sobrecarga. |
| 6 | El indicador luminoso (22) está encendido, la pantalla de visualización alfanumérica indica: CARGA NO PROTEG SOBRECARG SALIDA | El SAI está en sobrecarga. Los equipos conectados están directamente alimentados por la red eléctrica vía el By-pass. | Comprobar la potencia requerida por los equipos conectados y desconectar los equipos que no sean prioritarios. |
| 7 | El indicador luminoso (22) está encendido, la pantalla de visualización alfanumérica indica: REDUCIR CARGA REARRANQ. SAI | Después de sobrecargas repetitivas, el SAI está bloqueado en posición By-pass. Los equipos conectados están directamente alimentados por la red eléctrica. | Comprobar la potencia requerida por los equipos conectados y desconectar los equipos que no sean prioritarios. Parar y reiniciar el SAI al funcionamiento normal. |
| 8 | El indicador luminoso (22) está encendido, la pantalla de visualización alfanumérica indica: DEF SOBRECARGA REDUCIR CARGA | El SAI se ha parado automáticamente a causa de sobrecarga importante. | Comprobar la potencia requerida por los equipos conectados y desconectar los equipos que no sean prioritarios. |
| 9 | El indicador luminoso (22) está encendido, la pantalla de visualización alfanumérica indica: CORTOCIRCUIT CARG | El SAI se ha parado automáticamente a causa de cortocircuito en la salida del SAI. | Comprobar la instalación de la salida del SAI (cableado y conexión). Reparar el fallo. |

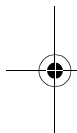



Anomalías en un SAI equipado con un módulo HotSwap MBP



| | Síntoma | Diagnóstico | Corrección |
|----|--|--|--|
| 12 | Los equipos conectados no están siendo alimentados cuando el conmutador rotativo (49) del módulo HotSwap MBP está en posición Bypass. | <ul style="list-style-type: none"> ▶ Los equipos están conectados en la salida del SAI en lugar de estar conectados al módulo HotSwap MBP. ▶ El cordón de la red eléctrica de alimentación está conectado en la entrada del SAI en lugar de estar conectado al módulo HotSwap MBP. | <ul style="list-style-type: none"> ▶ Compruebe el cableado del SAI y el módulo HotSwap MBP. (ver §2.6) |
| 13 | Los equipos conectados no están siendo alimentados cuando el conmutador rotativo (49) del módulo HotSwap MBP está en posición Normal. | <ul style="list-style-type: none"> ▶ El SAI está parado. ▶ El cableado no es conforme entre el SAI y el módulo HotSwap MBP. | <ul style="list-style-type: none"> ▶ Arrancar el SAI. ▶ Compruebe el cableado del SAI y el módulo HotSwap MBP. (ver §2.6) |
| 14 | Los equipos conectados no reciben alimentación en caso de corte de la corriente eléctrica. | <ul style="list-style-type: none"> ▶ El conmutador rotativo (49) del módulo HotSwap MBP está en posición Bypass. ▶ El cableado no es conforme entre el SAI y el módulo HotSwap MBP. | <ul style="list-style-type: none"> ▶ Poner el conmutador rotativo del módulo HotSwap MBP en posición Normal. ▶ Compruebe el cableado del SAI y el módulo HotSwap MBP. (ver §2.6) |

En caso de fallo que provoque la parada del SAI, pulsar el botón Marcha/Parada (27) para

5.2 Sustitución del módulo de batería

Recordatorio de las instrucciones de seguridad:



La batería presenta un riesgo de electrocución y una corriente de cortocircuito elevada. Se deben tomar las siguientes precauciones para cualquier intervención en los elementos de la batería:

- ▶ Quitarse de las manos relojes, anillos, alianzas, pulseras o cualquier otro objeto metálico.
- ▶ Utilizar herramientas cuyo mango esté aislado.

Desmontaje del módulo de batería

Modelo RT



A - Desatornillar el módulo de batería desde la cara delantera.

B - Retirar esa parte.



5. Mantenimiento

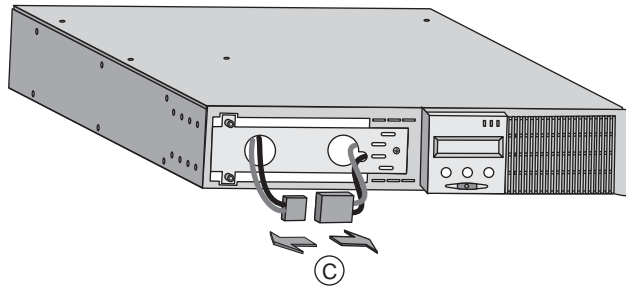

C - Desconectar el bloque de la batería (desconectando los 2 conectores de los cables).

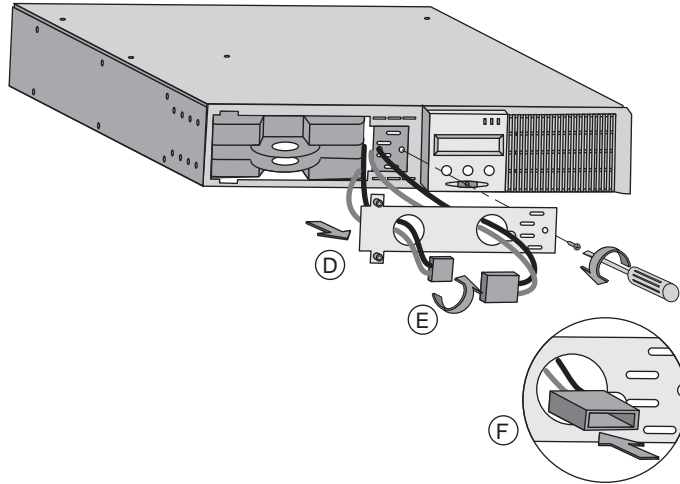

D - Quitar la cubierta metálica de protección de la batería quitando los tornillos.

E - Hacer pivotar el conector.

F - Pasar el conector a tra

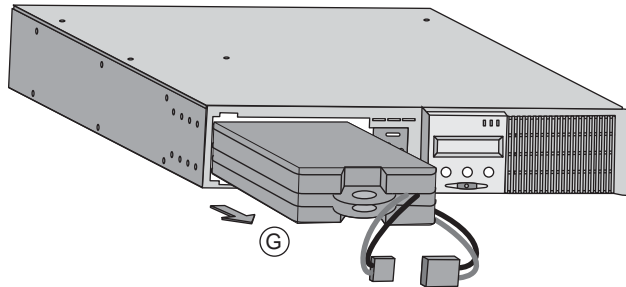
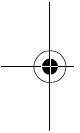

G - Extraer el bloque de la batería quitando la lengüeta de plástico de sustitución.

Modelo Torre



A - Desmontar la cara de la batería deslizando la cubierta hacia el lado del S



5.

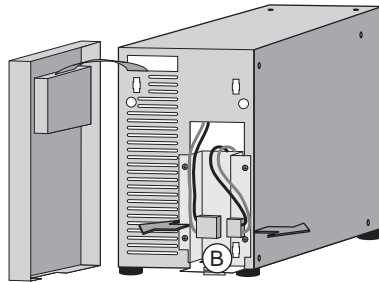

B - Desconectar los cables (separando los 2 cables de los cables).

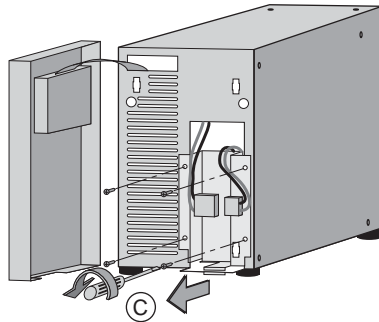

C - Retirar los 4 tornillos de la cubierta metálica de la batería.

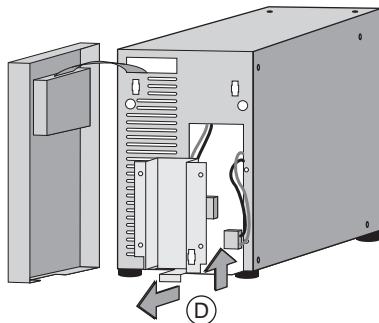

D - Quitar la cubierta de la batería.

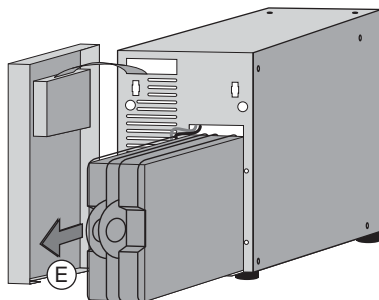

E - Extraer el módulo de la batería de la lengüeta de sustitución.

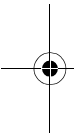

Montaje del nuevo módulo de batería



5. Mantenimiento

5.3 Mantenimiento de un SAI equipado con un módulo HotSwap MBP

Modelo RT

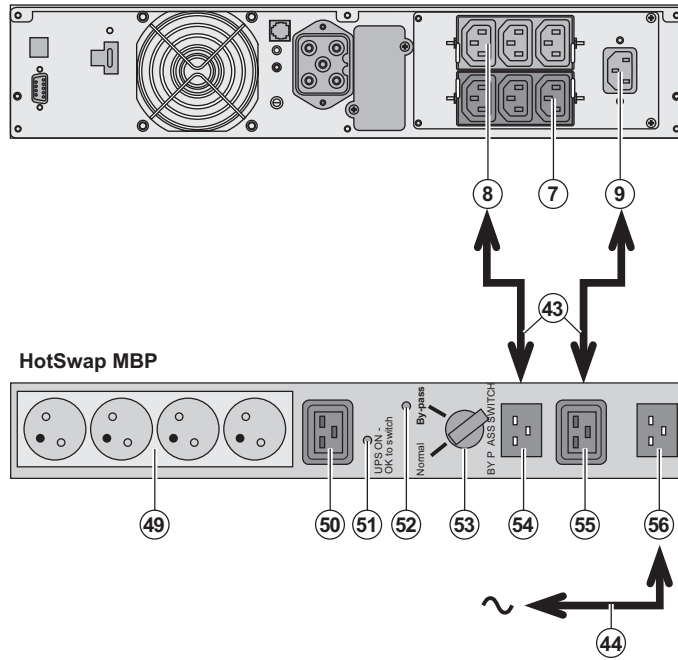

La función del módulo **HotSwap MBP** es permitir el mantenimiento eventual, la sustitución de un módulo que ello afecte a la alimentación de los equipos conectados (HotSwap).

Mantenimiento:

1 - Colocar el conmutador Bypass: el indicador luminoso del módulo **HotSwap MBP** se enciende para indicar que los equipos están alimentados directamente por la eléctrica.

2 - Parar el SAI pulsando el botón Parada (27) en la cara de la UPS. El indicador luminoso (55) "to switch" se apaga, ya se puede desconectar el SAI y sustituir el módulo.

Vuelta a funcionamiento:

1 - Comprobar que el SAI está correctamente conectado al módulo **HotSwap MBP**.

2 - Poner en marcha el SAI pulsando el botón Marcha/Parada (27) en la cara delantera del SAI: el indicador luminoso (51) "UPS ON - OK to switch" se enciende. En el caso contrario, hay un error entre el módulo **HotSwap MBP** y el SAI.

3 - Poner el conmutador Bypass en la posición Normal: el indicador luminoso del módulo **HotSwap MBP** se apaga.

4 - Los equipos están alimentados directamente por la eléctrica, protegidos por el SAI.

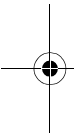



5.4 Centro de formación



Para adquirir dominio en la explotación de su aparato EATON e intervenir a primer nivel, un programa completo de formaciones técnicas en inglés y en francés.

For further information, please visit our website: www.eaton.com

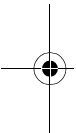



6. Anexos

6.1 Especificaciones técnicas

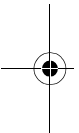
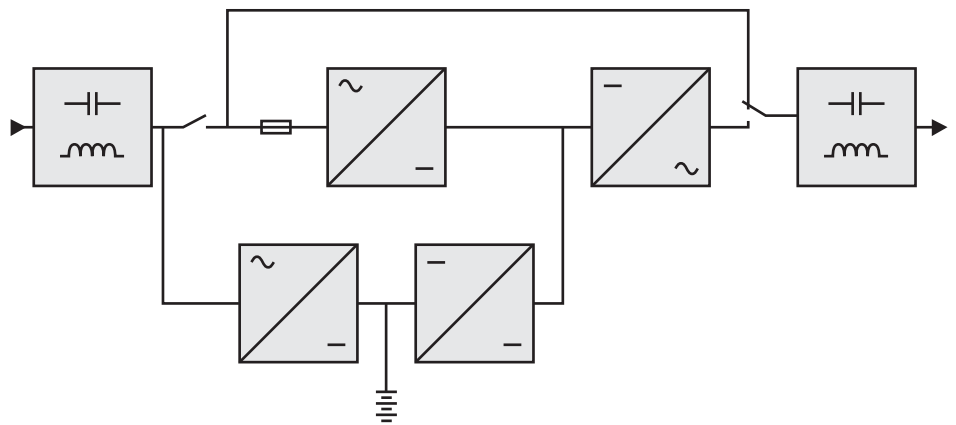

| | EX 700 | EX 1000 EX 1000 RT | EX 1500 EX 1500 RT |
|--------------------------------------|---|--|--|
| Potencia de salida | 700 VA / 630 W | 1000 VA / 900 W ⁽³⁾ | 1500 VA / 1350 W ⁽⁴⁾ |
| Red eléctrica de alimentación | <ul style="list-style-type: none"> ▶ Tensión ▶ Frecuencia ▶ Factor de potencia | | |
| | Monofásica 100 / 120 / 140 / 160 a 284 V ⁽⁵⁾ 50/60 Hz (autoselección) > 0,95 | | |
| Salida utilización | <ul style="list-style-type: none"> ▶ Tensión ▶ Frecuencia ▶ Distorsión armónica (THDV) ▶ Capacidad de sobrecarga | | |
| | Monofásica 230 V ±3% ⁽⁶⁾ 50/60 Hz ±0,5% ⁽⁷⁾ < 4% con carga lineal, < 6% con carga no lineal 102% permanente, 130% 12s, > 130% 2s | | |
| ▶ Corriente | 3 A ⁽⁸⁾ | 4,3 A ⁽⁸⁾ | 6,5 A ⁽⁸⁾ |
| Batería | 2x12 V - 7 Ah, de plomo hermético sin mantenimiento | 3x12 V - 7 Ah, de plomo hermético sin mantenimiento | 3x12 V - 9 Ah, de plomo hermético sin mantenimiento |
| Medio ambiente | <ul style="list-style-type: none"> ▶ Nivel acústico ▶ Temperatura de funcionamiento ▶ Humedad ▶ Corriente de fuga ▶ Temperatura de almacenamiento ▶ Altitud | | |
| | < 38 dBA 0°C a 40°C 20% a 90% (sin condensación) < 1,1 mA -25°C a 40°C 1000 m | | |
| Normas y certificación | <ul style="list-style-type: none"> ▶ Seguridad ▶ Prestaciones ▶ CEM ▶ Marcado | | |
| | IEC/EN 62040-1-1, EN 60950-1 (RD) IEC/EN 62040-3 EN 50091-2/IEC 62040-2 class B, IEC 61000-4-2/-3/-4/-6-8/-11, IEC 61000-3-2/-3 CE, TÜV/CB, UL, UL CB | | |



6.2 Glosario

| | |
|--|--|
| AC By-pass | Vía derivada de la red eléctrica de alimentación, controlada por el SAI, que permite la alimentación directa de los equipos a través de la red eléctrica en caso de fallo en el funcionamiento del ondulador. |
| AC Normal | Se trata de la red eléctrica de alimentación normal del SAI. |
| Arranque con batería | Permite la puesta en tensión de los equipos conectados al SAI en caso de fallo de la red eléctrica de alimentación. El SAI funciona entonces solamente con la batería. |
| Autonomía | Tiempo durante el cual los equipos son alimentados por el SAI con la batería. |
| Convertidor de frecuencia | Función que permite convertir la frecuencia de la red eléctrica de alimentación del SAI (50 Hz -> 60 Hz ó 60 Hz -> 50 Hz). |
| Descarga profunda | Descarga de la batería superior al límite permitido y que provoca el daño de la batería. |
| Equipos | Aparatos o dispositivos conectados en la salida del SAI. |
| FlexPDU | Módulo de tomas de salida del SAI para instalación en un bastidor, que permite la conexión de módulos correspondientes a diferentes tipos de tomas. |
| HotSwap MBP | Módulo de derivación manual del SAI con vistas al mantenimiento, que permite la conexión de tipos de módulos correspondientes a diferentes tipos de tomas. |
| Índice de carga | Relación entre la potencia consumida por los equipos conectados al SAI y la potencia máxima que puede suministrar el SAI. |
| Marcha/Parada del ondulador mediante software | Permite autorizar o prohibir al software de protección de los sistemas la activación de secuencias de Marcha/Parada del SAI. |
| Personalización | Programación de determinados parámetros diferente de la configuración de salida de fábrica. Determinadas funciones del SAI pueden ser modificadas mediante el Personal Solution-Pac para satisfacer mejor sus necesidades. |
| SAI | Alimentación Ininterrumpida. |
| Tomas programables | Tomas que pueden quedar desconectadas automáticamente de la salida del SAI cuando la batería (temporización de apertura programable con el software) está en estado de carga. El SAI lleva dos grupos de dos tomas programables. |
| Umbral de prealarma de final de autonomía de la batería | Se trata de un umbral del nivel de tensión de la batería que permite la activación del final de autonomía de la batería y tomar entonces las medidas necesarias. El SAI lleva dos umbrales de prealarma de final de autonomía de la batería. |
| Test de la batería | Test interno del SAI que permite comprobar el estado de la batería. |

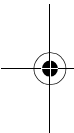

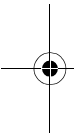



www.eaton.com

EX
700 - 1000
1000 RT -
EXB 1000
EXB 1000

Installatie
gebruiker

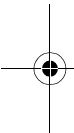

Pulsar Series

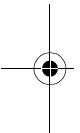



Hartelijk dank dat u een van de producten van EATON hebt gekozen voor de beveiliging v

De **EX**-lijn is met de grootst mogelijke zorg ontwikkeld.

Voor een optimaal gebruik van uw **UPS (Uninterruptible Power Supply - ononderbroken s**
adviseer wij u om de tijd te nemen en deze handleiding goed te lezen.

Lees voor het plaatsen van de **EX** dit boekje goed door. U vindt er belangrijke veiligheidsv
de aanwijzingen uit deze handleiding op.

Maak kennis met het leveringsprogramma van EATON en met de opties van de **EX**-lijn en
www.eaton.com, of neem contact op met uw vertegenwoordiger van EATON.

Zorg voor het milieu

Het beleid van EATON is gericht op bescherming en behoud van het milieu.
Onze producten worden milieuvriendelijk ontworpen.

Stoffen

Dit toestel bevat geen CFC's, HCFC's of asbest.

Verpakking

Om afval beter te verwerken en recycling te bevorderen moeten de onderdelen van de ve
worden verwerkt.

- ▶ De doos bestaat voor meer dan 50% uit gerecycled karton.
- ▶ Zakken en zakjes zijn gemaakt van polyethyleen.
- ▶ Het verpakkingsmateriaal is geschikt voor recycling en voorzien van het

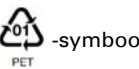

| Materiaal | Afkorting | Nummer in l |
|-----------------------------|-----------|-------------|
| Polyethyleen tereftalaat | PET | 01 |
| Hoge-dichtheid polyethyleen | HDPE | 02 |
| Polyvinylchloride | PVC | 03 |
| Lage-dichtheid polyethyleen | LDPE | 04 |
| Polypropyleen | PP | 05 |
| Polystyreen | PS | 06 |

Houd u aan de ter plaatse geldende voorschriften voor het verwerken van de verpakking.

Einde levensduur

EATON streeft ernaar om afgedankte producten te verwerken volgens de ter plaatse geld
voorschriften.

EATON werkt samen met bedrijven die onze afgedankte producten inzamelen en verwerk

Product

Het product is vervaardigd van recyclebare materialen.

Ontmanteling en vernietiging moeten plaatsvinden volgens de ter plaatse geldende voors
van afval.

Afgedankte producten moeten worden aangeboden bij een centrum voor verwerking van
afval.

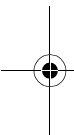



Inleiding

Gebruikte pictogrammen



Volg deze aanwijzingen altijd op.



Informatie, tips, hulp.



Handel volgens de zichtbare aanduiding.



Voer de aangegeven handeling uit.



Geluidssignaal.

In deze handleiding wordt het branden van lampjes in de illustraties als volgt aangegeven:



Lampje uit.



Lampje aan.



Knipperend lampje.

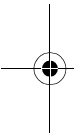



1. Beschrijving

1.1 Standaardopstellingen

Tower-opstelling

Rack-opstelling

1.2 Achterkant

EX 700 / 1000 / 1500

EX 1000 RT / 1500 RT

EX EXB (optionele accumodule)

EX EXB RT (optionele accumodule)

1.3 Bedieningspaneel

2. Installatie

2.1 Uitpakken en controle van de inhoud

2.2 Installatie van RT-model in tower-opstelling

2.3 Installatie van RT-model in rack-opstelling

2.4 Communicatiepoorten

Aansluiten van de RS232- of USB-communicatiepoort (facultatief)

Installatie van communicatiekaarten (optie)

2.5 Eigenschappen van de contactgestuurde communicatiepoort

2.6 Aansluiting op een FlexPDU-module (Power Distribution Unit - elektrisch)

2.7 Aansluiting op een HotSwap MBP-module

Werking van de HotSwap MBP-module

2.8 Aansluiten van een UPS zonder FlexPDU- of HotSwap MBP-module

3. Gebruik

3.1 Ingebruikname en normaal bedrijf

3.2 Accubedrijf

3.3 Terugkeer van het elektriciteitsnet

3.4 Uitschakelen van de UPS

3.5 Gebruik van de remote bedieningsfuncties van de UPS

4. Instellingen en toegang tot metingen

4.1 Overzicht van de display

4.2 Toegang tot metingen

4.3 Instellingen via bedieningspaneel

4.4 Instellingen met externe software

5. Onderhoud

5.1 Storingen

Storingen bij een UPS met HotSwap MBP-module

5.2 Vervangen van de accumodule

Veiligheidsvoorschriften

Demonteren van de accumodule

Plaatsen van de nieuwe accumodule

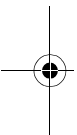



1. Beschrijving

1.1 Standaardopstellingen

Tower-opstelling

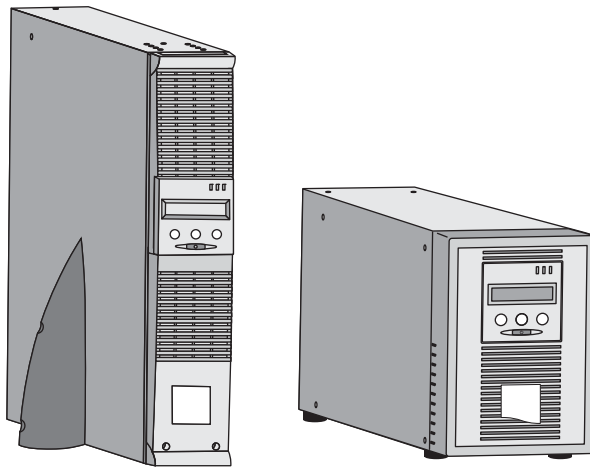

| Overzicht afmetingen (in mm) | |
|------------------------------|---|
| EX 700 | 2 |
| EX 1000 | 2 |
| EX 1000 RT | 8 |
| EX 1500 | 2 |
| EX 1500 RT | 8 |
| EX EXB | 2 |
| EX EXB RT | 8 |

| Overzicht gewichten in kg | |
|---------------------------|---|
| EX 700 | 1 |
| EX 1000 | 1 |
| EX 1000 RT | 1 |
| EX 1500 | 1 |
| EX 1500 RT | 2 |
| EX EXB | 2 |
| EX EXB RT | 2 |

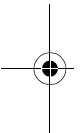

Rack-opstelling

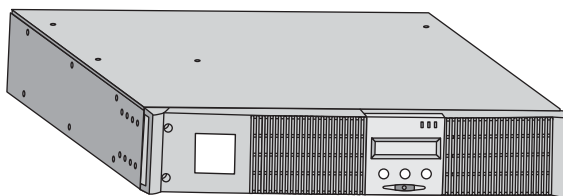



1.2 Achterkant

EX 700 / 1000 / 1500

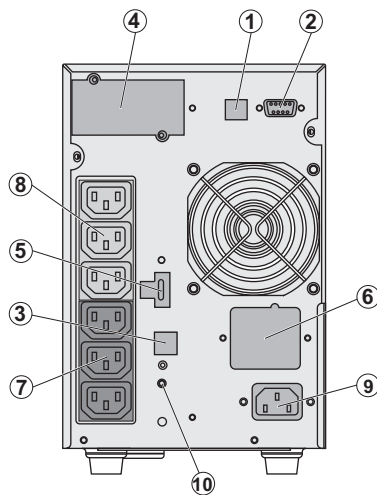

- (1) USB-commu
- (2) RS232-comm
- contacten.
- (3) Connector v
- herkenning van
- (behalve EX 700
- (4) Plaats voor c
- communicatiek
- (5) Connector v
- Remote On/Off
- (6) Connector v
- accumodule EX
- (7) Groep van 3
- voor het aanslu
- (8) Groep van 3
- aansluiten van
- (9) Aansluiting
- voedingsnet
- (10) Waarschuw
- omkering/nulle
- (SWF)

EX 1000 RT / 1500 RT

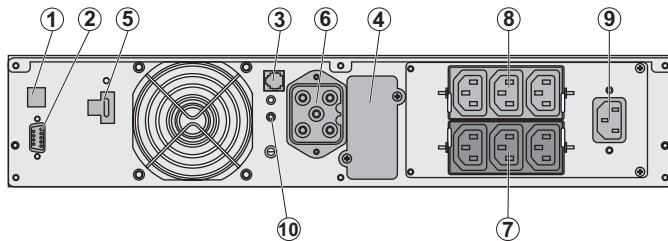
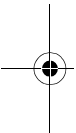

EX EXB (optionele accumodule)

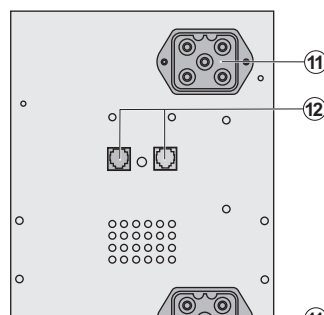

- (11) Connectore
- de accumodule
- accumodules)
- (12) Connectore
- herkenning van



1. Beschrijving

EX EXB RT (optionele accumodule)

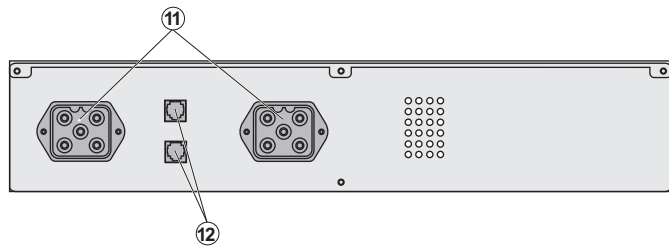

1.3 Bedieningspaneel

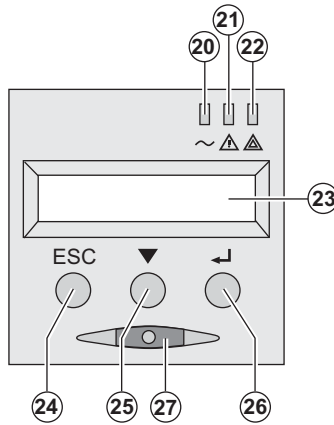

- (20) Lampje beveiligde a
 - (21) Lampje storingsbed
 - (22) Lampje niet-beveilig
 - (23) Alfnumeriek displa
 - (24) Knop Stoppen, Teru
 - (25) Scrolltoets
 - (26) Bevestigingstoets
 - (27) Aan-/Uitknop (ON/O
- de uitgaande contactdoz

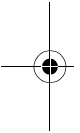



2.1 Uitpakken en controle van de inhoud

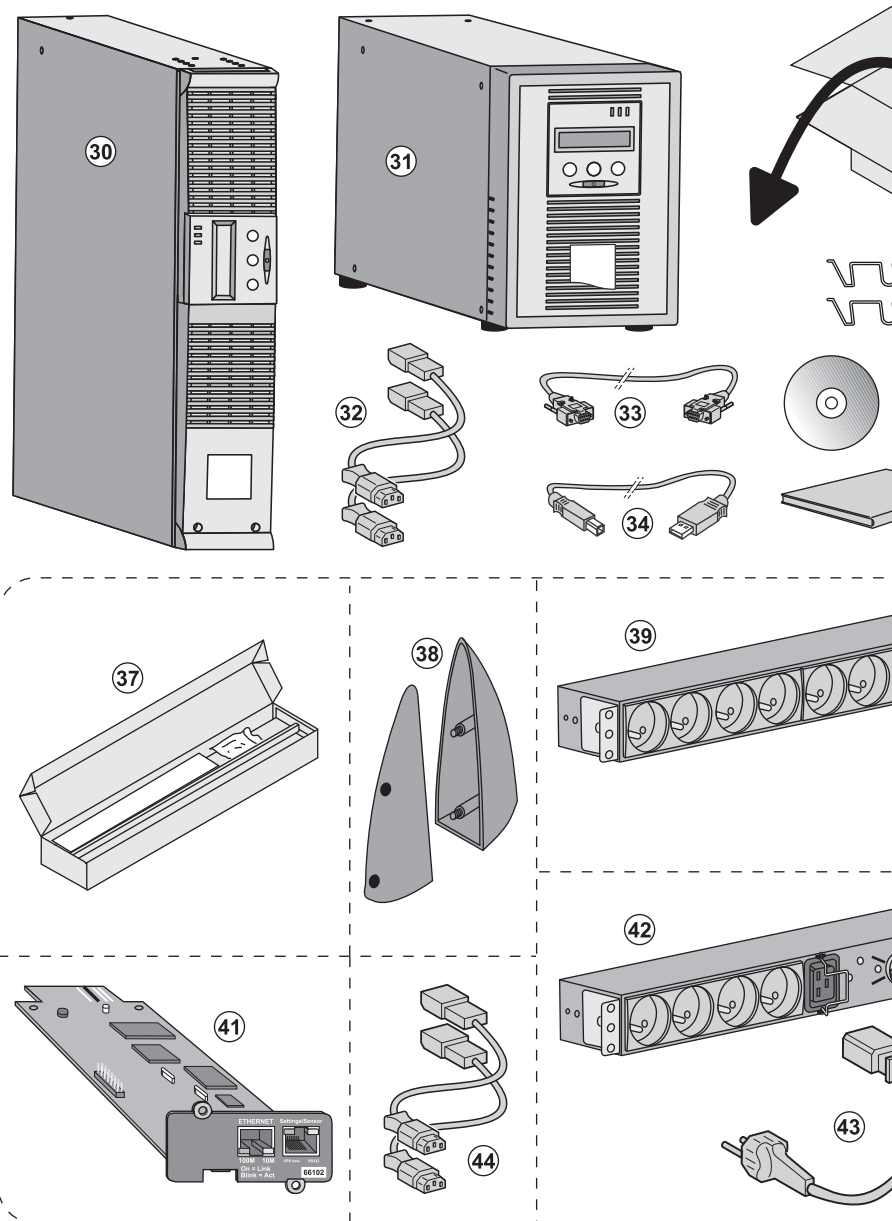

(30) EX 700, 1000, 1500.

(31) EX 1000 RT, 1500 RT.

(32) 2 snoeren voor het aansluiten van de apparatuur.

(33) RS232 communicatiekabel.

(34) USB-communicatiekabel.

(35) Vergrendelingssysteem voor de voedingskabels

Afhankelijk van uitvoering of optie.

(37) Montageset voor 19 inch ka

(38) 2 steunen voor verticale pla

(39) FlexPDU-module (optie).

(40) Aansluitsnoer van FlexPDU

(41) NMC-communicatiekaart (o



2. Installatie

2.2 Installatie van RT-model in tower-opstelling

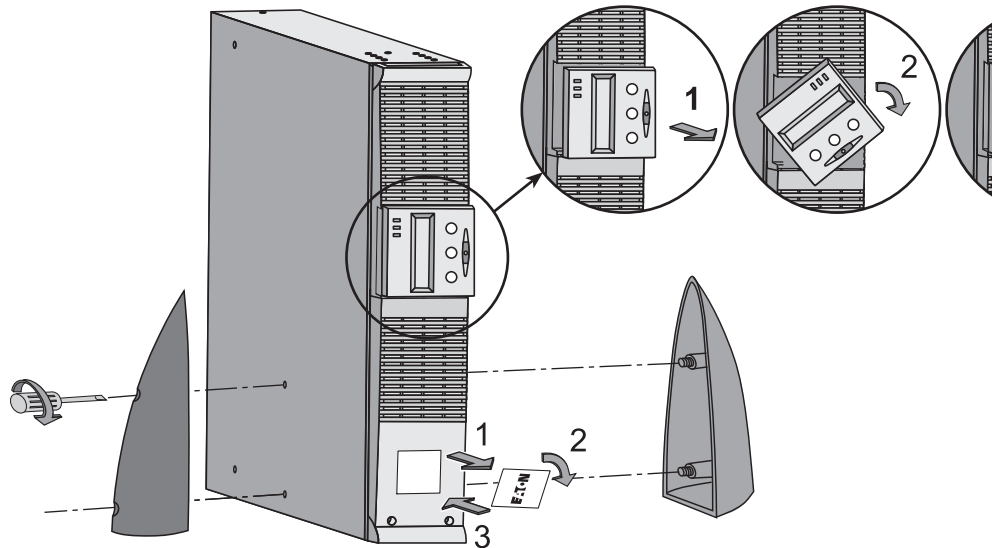

2.3 Installatie van RT-model in rack-opstelling

Het wordt aangeraden de EXB-accumodule(s) zo laag mogelijk in het rack te installeren en de UPS te plaatsen.

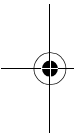

Volg de stappen 1 tot en met 4 voor het monteren van de module op zijn rails.

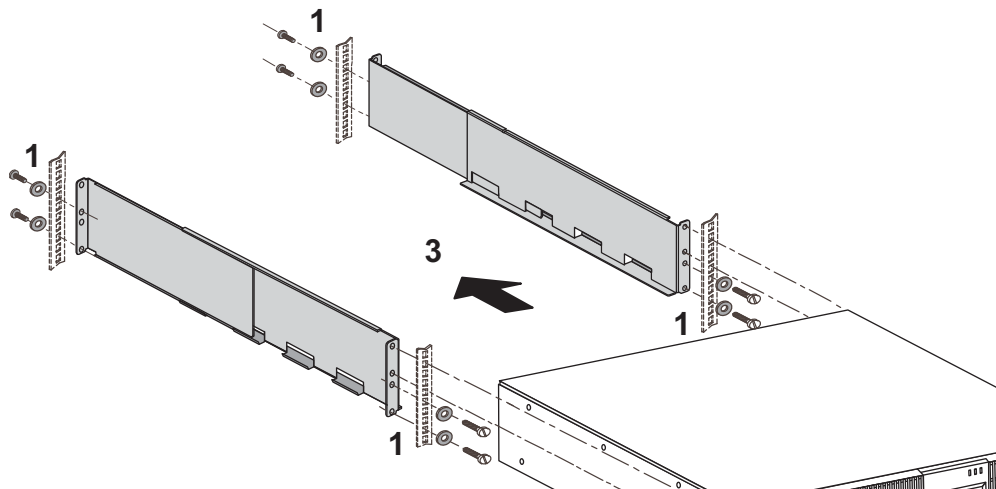



2.4 Communicatiepoorten

Aansluiten van de RS232- of USB-communicatiepoort (facultatief)



De RS232-communicatiepoort en de USB-communicatiepoort kunnen niet tegelijkertijd in gebruik zijn.

Tower-model

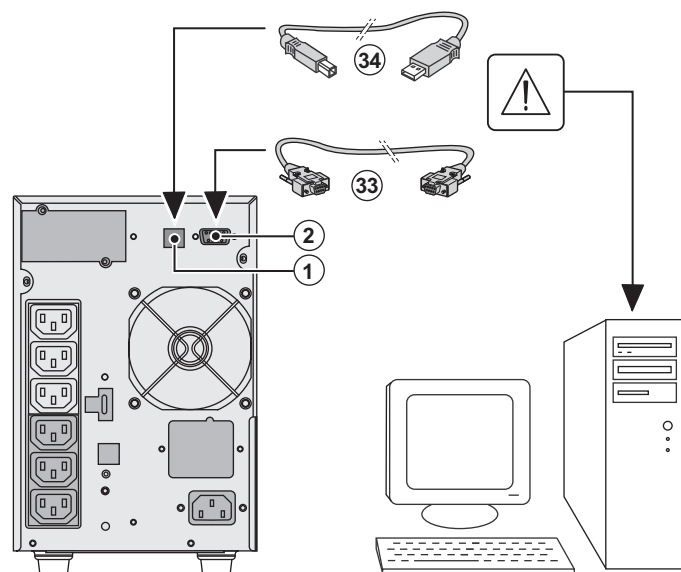

1 - Sluit de RS 232-communicatiepoort of de USB-communicatiepoort aan op de seriële of USB-communicatiepoort van het computerapparaat.

2 - Sluit het andere uiteinde van de RS232- of USB-communicatiepoort aan op de seriële of USB-communicatiepoort van het computerapparaat.

De UPS kan nu worden gebruikt voor besturings-, beveiligingssoftware en andere toepassingen.

RT-model

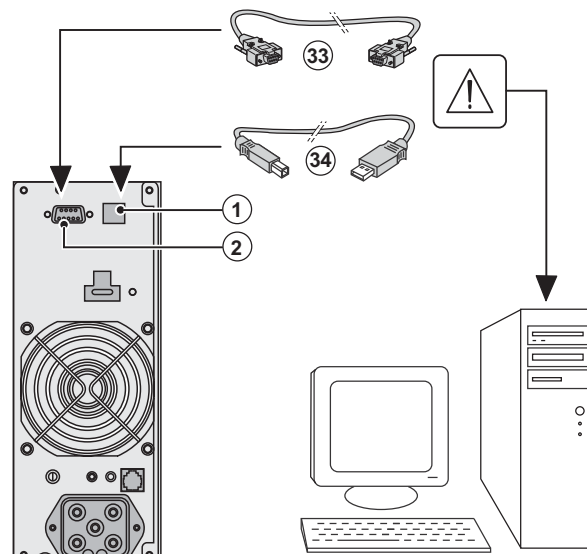



2. Installatie

Installatie van communicatiekaarten (optie)



Tower-model

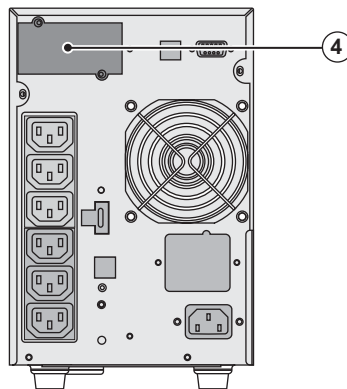

RT-model

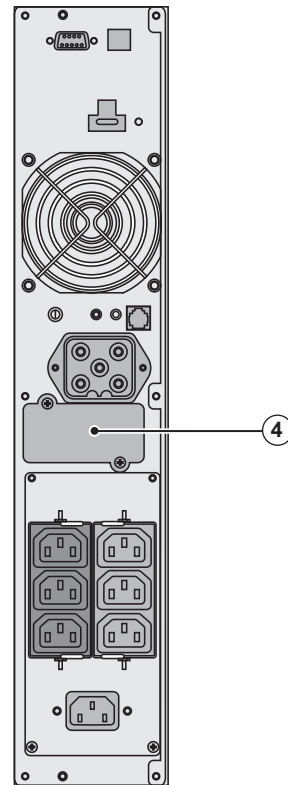

De UPS hoeft niet te worden verwijderd om de communicatiekaart te installeren. (4): Plaatsing van de communicatiekaart met beperkte toegang.

- 1 - Verwijder het beschermende deksel van de UPS (dit is bevestigd met een schroef).
- 2 - Plaats de communicatiekaart in de daarvoor bestemde plaats.
- 3 - Breng het afdekplaatje terug op zijn plaats en schroef het vast.

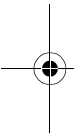

2.5 Eigenschappen van de contactgestuurde communicatiepoort (2)

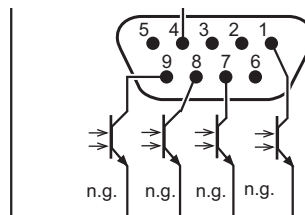

gemeenschappelijke geleider

- ▶Pinnen 2, 3, 5 en 6 : niet in gebruik,
- ▶Pin 1 : werking op automatische bypass,
- ▶Pin 4 : gemeenschappelijke geleider aangesloten op de communicatiepoort,
- ▶Pin 7 : vooralarm einde autonomie batterij,
- ▶Pin 8 : aangesloten apparatuur beveiligd,
- ▶Pin 9 : werking op batterij.

n.o.: contact normaal open.

Als een statusinformatie actief is, is het contact tussen de gemeenschappelijke pin 4 en de pin van de statusinformatie gesloten.

Eigenschappen van de contacten (optische koppel-elementen)

- ▶Spanning: max. 48 V DC,
- ▶Stroom: max. 25 mA,
- ▶Vermogen: 1,2 W.



2.6 Aansluiting op een FlexPDU-module (Power Distribution Unit - elektrische verdeeldoos) (optie)

RT-model

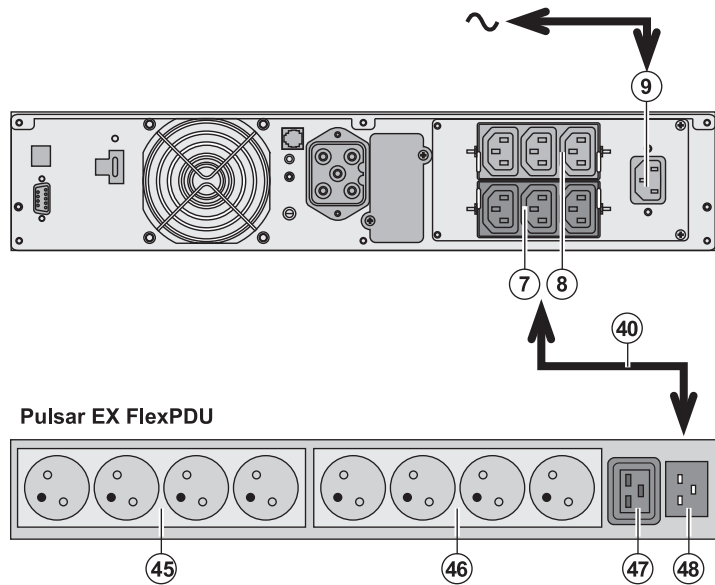

1 - Sluit de ingang van de UPS op de netspanning van de voedingsapparatuur.

2 - Verbind de ingang van de elektrische netvoeding (48) met de uitgang van de UPS door middel van de kabel (40) IEC 10A/16A. De aansluitingen zijn afgebeeld op de afbeelding.

3 - Sluit de apparatuur aan op de contactdozen (45-47) van de FlexPDU-module.

4 - Borg de kabel van de FlexPDU-module vast aan de klemmen van de UPS.

2.7 Aansluiting op HotSwap MBP-module (Optie)

Met een **HotSwap MBP**-module kan de UPS worden onderhouden en eventueel vervangen zonder elektrische voeding van de aangesloten apparatuur (**HotSwap**-functie).

RT-model

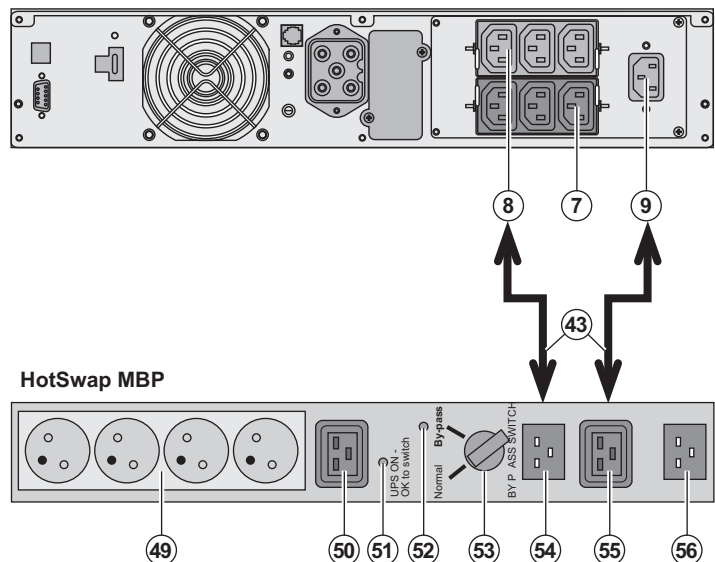

1 - Sluit de ingang van de UPS op de netspanning van de voedingsapparatuur door middel van de kabel (44).

2 - Verbind de ingang van de elektrische netvoeding "UPS Input" (55) van de HotSwap MBP-module door middel van de kabel (43) met de uitgang van de UPS. Deze aansluitingen zijn afgebeeld op de afbeelding.

3 - Verbind de uitgang van de UPS met de "UPS Output" van de HotSwap MBP-module door middel van de kabel (43) met de aansluitingen van de HotSwap MBP-module. Het is noodzakelijk om de HotSwap MBP-module te gebruiken voor het onderhoud van de UPS.



2. Installatie

Werking van de HotSwap MBP-module

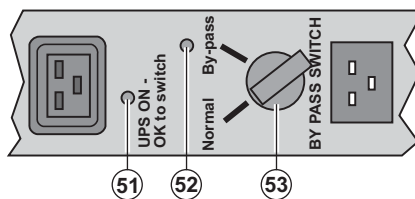

De **HotSwap MBP**-module is een draaischakelaar (53)

Normal: de apparatuur wordt gevoed door de UPS.

By-pass: de apparatuur wordt gevoed door het elektriciteitsnet

In bedrijf stellen van de UPS met de HotSwap MBP-module:

- 1 - Controleer of de UPS goed op de **HotSwap MBP**-module is aangesloten.
- 2 - Zet de schakelaar (53) op Normal.
- 3 - Start de UPS door op de Aan/Uit-knop (27) aan de voorkant van de UPS te drukken. De apparatuur wordt nu door de UPS gevoed. Lampje (51) "UPS ON - OK to switch" gaat nu branden op de **HotSwap MBP**-module.

Testen van de HotSwap MBP-module

- 1 - Zet de schakelaar (53) op By-pass en controleer of de apparatuur nog steeds wordt gevoed.
- 2 - Zet de schakelaar (53) weer op Normal.

2.8 Aansluiten van een UPS zonder FlexPDU-of HotSwap MBP-module



Controleer de opschriften op het typeplaatje aan de achterkant van het toestel overeenkomen met het elektriciteitsnet en het feitelijke stroomverbruik van de aangesloten apparatuur.

Tower-model

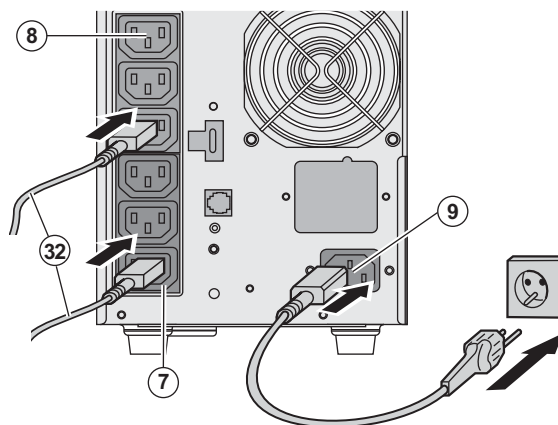

1 - Sluit de ingangscable van de UPS op de netspanning van de voedingskabel van de apparatuur.

2 - Sluit de apparatuur op de snoeren (32).

Sluit de belangrijkste apparatuur voorkeur aan op de 3 contactdozen (7) die per minder belangrijke apparatuur worden geprogrammeerd.

Gebruik een EATON ene software om de aansluitingen te sturen of te programmeren.



RT-model

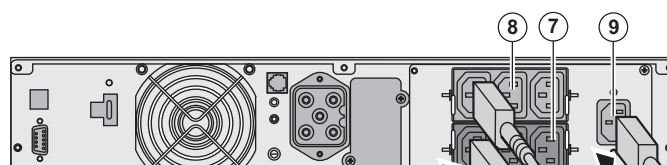



3.1 Ingebruikname en normaal bedrijf



Wanneer het toestel voor de eerste maal wordt opgestart, moet de netspanning aanwezig zijn. Het toestel brengt bekabelingsfouten aan het licht te brengen. Daarna kan het toestel ook worden opgestart wanneer de netspanning aanwezig is.

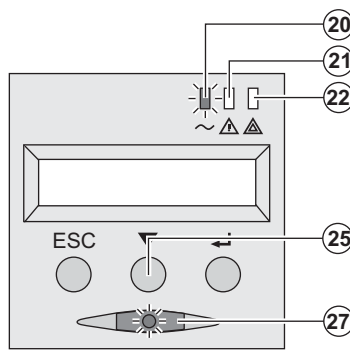

Druk gedurende ongeveer 1 seconde op knop (25).
 ► De zoemer geeft een geluidssignaal en de lampjes (20) en (21) branden.
 ► Vervolgens geeft de zoemer tijdens de aanpak van de stroom onderbreking drie geluidssignalen, waarna knop (27) blijft branden. Dit geeft aan dat de uitgaande contactdozen worden geopend.



De aangesloten apparatuur wordt nu doorgeschakeld op de accu.
 ► Lampje (20) brandt.
 Als lampje (22) brandt, is er een storing aan de uitgaande contactdozen ("Storingen").
 ► Bij normaal bedrijf kunnen met de scrollknop (25) de foutcodes worden uitgelezen die op de UPS worden opgeslagen (bijvoorbeeld Normal- en AC By-passnetten, bedrijfstype, fabrieksdatum en serienummer van de UPS).

Instellen van de UPS



Wanneer het de bedoeling is om de UPS op een bepaalde manier in te stellen, wordt aanbevolen om de instellingen te wijzigen. Het menu Instellingen van de UPS wordt bij deze stap te maken via het menu Instellingen van de UPS. Dit menu is toegankelijk via de knoppen van het bedieningspaneel of met de **Personal Software** van de UPS. Dit menu is toegankelijk via de knoppen van het bedieningspaneel of met de **Personal Software** van de UPS die op de **Solution-Pac-CD-ROM** van EATON staat.

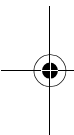

3.2 Accubedrijf

Overschakelen op accubedrijf

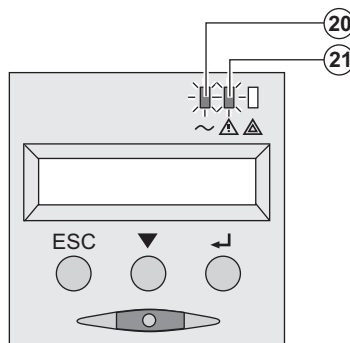

► De voeding van de aangesloten apparatuur wordt overgenomen op het moment dat het elektrische net geen energie wordt dan door de accu geleverd.
 ► De lampjes (20) en (21) branden.
 ► Om de 10 seconden klinkt een geluidssignaal.

De aangesloten apparatuur wordt door de accu gevoed.
Op de display staat aangegeven hoe lang de accu kan leveren.

Drempelwaarde voor de waarschuwing "Accu bijna leeg"



► De lampjes (20) en (21) branden.
 ► Om de drie seconden klinkt een waarschuwingssignaal.



3. Gebruik

Accu leeg



- ▶ Alle lampjes zijn uit.
- ▶ Het akoestische waarschuwingssignaal is uit.



De UPS is volledig uitgeschakeld.

3.3 Terugkeer van de netspanning

Nadat hij is uitgeschakeld, start de UPS automatisch weer op zodra de netspanning terugkeert (tenzij de UPS is uitgeschakeld via instellingen van de UPS); de aangesloten apparatuur wordt weer gevoed.

3.4 Uitschakelen van de UPS

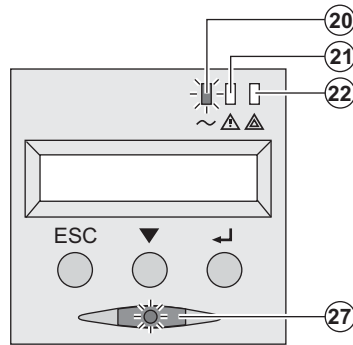

Druk langer dan 2 seconden op knop (27).

De op de UPS aangesloten apparatuur wordt niet

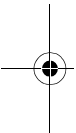

3.5 Gebruik van de remote bedieningsfuncties van de UPS

EX biedt keus uit twee remote bedieningssystemen.

▶ **RPO**: functie voor remote uitschakelen van de UPS (**R**emote **P**ower **O**ff) die gebruikt wordt om alle aangesloten apparatuur door middel van een remote gebruikerscontact uit te schakelen.

De UPS moet daarna handmatig weer ingeschakeld worden.

▶ **ROO**: functie voor remote in- en uitschakelen van de UPS (**R**emote **O**n/**O**ff) die remote gebruik van de UPS mogelijk maakt.

Deze functies worden mogelijk gemaakt door opening van een contact dat wordt aangesloten tussen de pinnen van de connector (5) aan de achterkant van de UPS (zie de figuren hierna).



RT-model

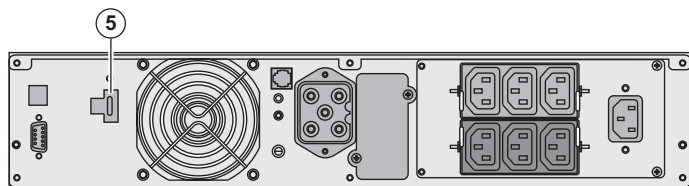

Tower-model

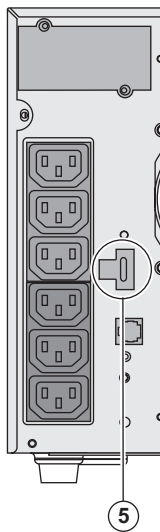

Aansluiten en testen van remote bedieningsfuncties



- 1 - Controleer of de UPS op OFF staat en van het elektrische voedingsnet losgekoppeld is.
- 2 - Verwijder de connector (5) door de schroeven los te draaien.
- 3 - Sluit een geïsoleerd droog normaal gesloten contact (60 VDC / 30 VAC max., 20 mA max.) aan tussen de twee pinnen van de connector (5), zie figuur.

=

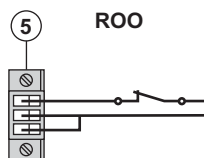

Contact open: UPS schakelt uit
Contact gesloten: UPS schakelt in (indien UPS aangesloten op netspanning aanwezig)

N.B.: lokaal in/uit-schakelen met knop (27) blijft voorrang hebben

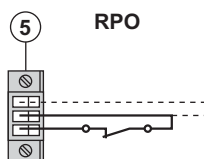

Contact open: UPS schakelt uit
Om terug te gaan naar normale modus moet u het externe contact uitschakelen desactiveren en de UPS herstarten met knop (27).

- 4 - Steek de connector (5) in het daarvoor bestemde contactgat aan de achterkant van de UPS.
- 5 - Sluit de UPS aan en herstart het systeem volgens de hierboven beschreven procedure.
- 6 - Activeer het externe contact voor remote uitschakelen om de functie te testen.



Waarschuwing: deze connector mag uitsluitend op ZLVS-circuits (zeer lage veiligheidsspanning) worden gebruikt.



4. Toegang tot metingen en instellingen

4.1 Overzicht displayweergaves

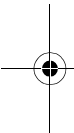
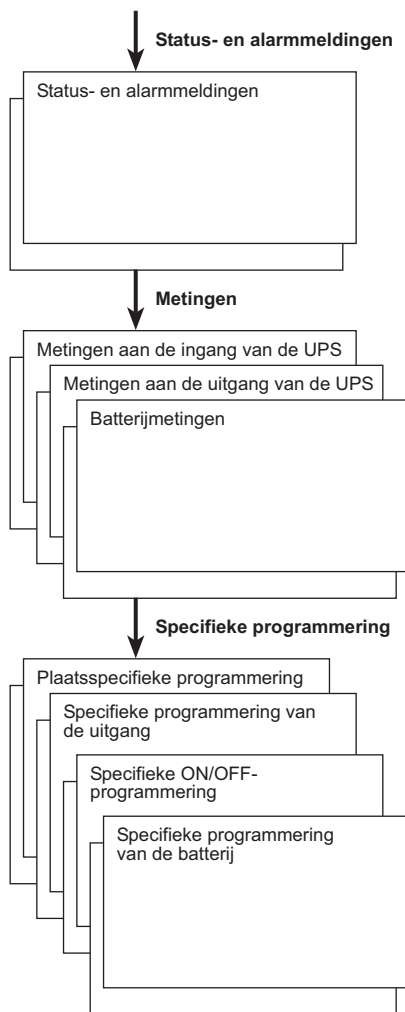

4.2 Toegang tot metingen

Door meerdere keren op de scrolltoets **(25)** te drukken komt u bij de status en eventuele alarmmeldingen, metingen van spanning, stroom, frequentie, geleverd vermogen en gebruiksduur van de accu.

4.3 Instellingen via bedieningspaneel

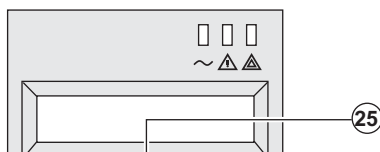

- Druk een aantal keren op de scrolltoets **(25)** om naar het instellingenmenu te gaan.
- Met de Bevestigingstoets **(26)** gaat u naar de verschillende keuzemogelijkheden.
- Bevestig ten slotte uw keuze door opnieuw op de Bevestigingstoets **(26)** te drukken.



4. Toegang tot metingen en

Output-instellingen

| Functie | Fabrieksinstellingen | Andere keuzemogelijkheden | Opmerking |
|---|---|--|--|
| Uitgangsspanning ⁽¹⁾ | 230 volt AC | 200/208/220/240/250 volt AC | |
| Frequentie-omzetter ⁽¹⁾ | Uit | Aan | De aangesloten apparaten moeten nooit oververhit raken. |
| Uitgangsfrequentie ⁽¹⁾ | Automatische selectie | 50/60 Hz | Kan alleen worden geselecteerd als de frequentie-omzetter is ingesteld op Aan. |
| Overschakeling op AC By-pass-elektriciteitsnet ⁽¹⁾ | Als het AC By-pass-elektriciteitsnet de toleranties niet overschrijdt | Als het AC By-pass de toleranties overschrijdt | |
| Overbelastingsniveau ⁽¹⁾ | 100% | 30 / 50 / 70% | Waarschuwing drempelwaarde |

(1) Deze parameters kunnen alleen worden gewijzigd wanneer de **UPS** is uitgeschakeld (Off-line). Een uitgebreide toelichting is opgenomen in de **Personal Solution-Pac**-software.

Instellen Aan/Uit (ON/OFF)

| Functie | Fabrieksinstellingen | Andere keuzemogelijkheden | Opmerking |
|---|----------------------|---------------------------|--|
| Opstarten op accu | Aan | Uit | |
| Automatisch opnieuw opstarten | Aan | Uit | Automatisch opstarten van de UPS bij terugkomst van de netspanning. |
| Energiebesparing | Uit | Aan | Als de functie automatisch wordt ingesteld op Aan, wordt de UPS bij vermogenspieken automatisch op energiebesparing ingesteld. |
| Waarnemen van fase-omkering/nulleider (SWF) | Uit | Aan | Als de functie automatisch wordt ingesteld op Aan, blijft de UPS bij fase-omkering of nulleider waargenomen. |

Instellingen accu

| Functie | Fabrieksinstellingen | Andere keuzemogelijkheden | Opmerking |
|--------------------------------------|--|-------------------------------------|-----------------------|
| Accutest | Wekelijks | Geen test / dagelijks / maandelijks | |
| Voorwaarschuwing "accu bijna leeg" | 20% | 0-100% | Resolutie van de accu |
| Keuzemogelijkheden gebruiksduur accu | Automatische detectie van het aantal accumodules | 13-200 Ah | |

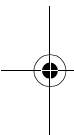



5. Onderhoud

5.1 Storingen



Als lampje **(21)** of **(22)** brandt, is er sprake van een storing of van een alarm. Gebruik de Knop Stoppen toets **(24)** om het alarm uit te schakelen.

| | Gebeurtenis | Oorzaak | Oplossing |
|---|---|---|--|
| 1 | De UPS start niet, op de alfanumerieke display staat: COLD START NOK CHECK AC WIRING | De netspanning is afwezig of aangesloten op de uitgang van de UPS. | Controleer of de U netspanning aang |
| 2 | Lampje (22) brandt, en lampje SWF (11) brandt op de achterkant van de UPS. Op de alfanumerieke display staat: FASE/NUL VERW. CONTR. BEDRADING | Fase-omkering van het voedingsnet. De UPS schakelt niet in. | Herstel voor elek met geaarde nulle bekabeling als vo netwerkaansluitin hem 180° (type D schakel een elektr aansluiting te wijz Schakel de detec andere typen elek |
| 3 | Lampje (22) brandt, op de alfanumerieke display staat: GEEN BATTERIJ CONTR. AANSLUIT. | De accu is niet goed aangesloten. | Controleer de aan accu (zie §5.2, Ver accumodule). |
| 4 | Lampje (22) brandt, op de alfanumerieke display staat: BATTERIJ FOUT BEL EATON SERVICE | Er is een storing aan de accu waargenomen. | Vervang de accu Vervangen van de Neem contact op afdeling. |
| 5 | Lampje (21) brandt, op de alfanumerieke display staat: BEL. TE GROOT VERMINDER BEL. | Het belastingniveau is hoger dan het geprogrammeerde overbelastingniveau of de capaciteit van de UPS. | Controleer het ve wordt opgenomen aangesloten appa ontkoppel minder apparatuur. Contr geprogrammeerd overbelastingnive |
| 6 | Lampje (22) brandt, op de alfanumerieke display staat: BEL. ONBESCHERMD BEL. TE GROOT | De UPS is overbelast. De aangesloten apparatuur wordt direct door de netspanning gevoed via het Bypass-circuit. | Controleer het ve wordt opgenomen aangesloten appa ontkoppel minder apparatuur. |
| 7 | Lampje (22) brandt, op de alfanumerieke display staat: VERMINDER BEL. RESTART UPS | Als gevolg van herhaaldelijke overbelasting is de UPS geblokkeerd in Bypass-stand. De aangesloten apparatuur wordt direct door de netspanning gevoed. | Controleer het ve wordt opgenomen aangesloten appa ontkoppel minder apparatuur. Schakel de UPS u weer in om terug normale modus. |
| 8 | Lampje (22) brandt, op de alfanumerieke display staat: BEL. TE GROOT VERMINDER BEL. | De UPS is automatisch uitgeschakeld vanwege een aanzienlijke overbelasting. | Controleer het ve wordt opgenomen aangesloten appa ontkoppel minder apparatuur. |
| 9 | Lampje (22) brandt, op de alfanumerieke display staat: | De UPS is automatisch uitgeschakeld vanwege | Controleer de inst uitgang van de U |

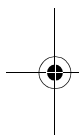



Storingen op een UPS met HotSwap MBP-module



| | Probleem | Oorzaak | Oplossing |
|----|---|---|---|
| 12 | De aangesloten apparatuur wordt niet gevoed wanneer de draaischakelaar (49) van de HotSwap MBP -module op By-pass staat. | <ul style="list-style-type: none"> De apparatuur is aangesloten op de uitgang van de UPS en niet op de HotSwap MBP-module. De voedingskabel naar het elektriciteitsnet is aangesloten op de ingang van de UPS en niet op de HotSwap MBP-module. | Controleer de UPS en de module. |
| 13 | De aangesloten apparatuur wordt niet gevoed wanneer de draaischakelaar (49) van de HotSwap MBP -module op Normal staat. | <ul style="list-style-type: none"> De UPS is uit. Er is een probleem met de kabels tussen de UPS en de HotSwap MBP-module. | <ul style="list-style-type: none"> Start de UPS op. Controleer de UPS en de module (zie §2.6). |
| 14 | De aangesloten apparatuur wordt niet gevoed vanwege een storing in het elektriciteitsnet. | <ul style="list-style-type: none"> De draaischakelaar (49) van de HotSwap MBP-module staat op By-pass. Er is een probleem met de kabels tussen de UPS en de HotSwap MBP-module. | <ul style="list-style-type: none"> Zet de draaischakelaar op HotSwap. Controleer de UPS en de module (zie §2.6). |

Druk bij uitval van de UPS door een storing op de Aan/Uit-knop (27) om de storing te kwijten.

5.2 Vervangen van de accumodule

Let op: neem de volgende veiligheidsvoorschriften in acht:



Bij werken aan de accu bestaat de kans op elektrische schokken en een hoge kortsluitstroom. Neem de volgende veiligheidsmaatregelen in acht:

- Draag geen horloges, ringen, armbanden of andere metalen voorwerpen aan uw handen.
- Gebruik gereedschap met een geïsoleerde handgreep.

Demonteren van de accumodule

RT-model

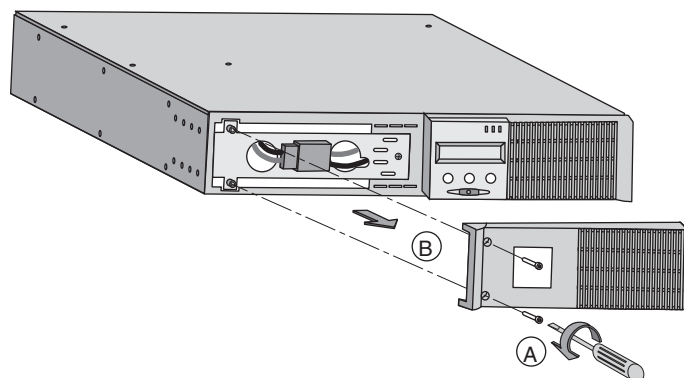

- A - Schroef het dekscherm los. Dit is met 2.
- B - Verwijder de accumodule.



5. Onderhoud

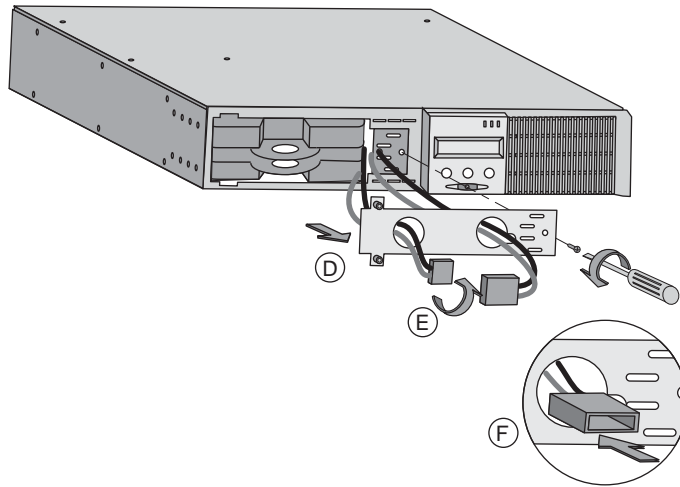

D - Verwijder de metalen
van de accu. Deze is met
bevestigd.

E - Draai de connector.

F - Haal de connector do

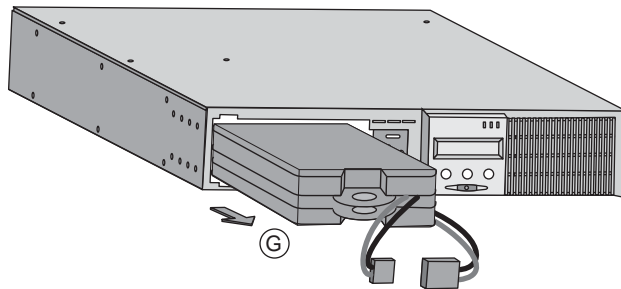

G - Trek aan de plastic lip
uit het toestel te halen en
accublok.

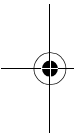

Tower-model

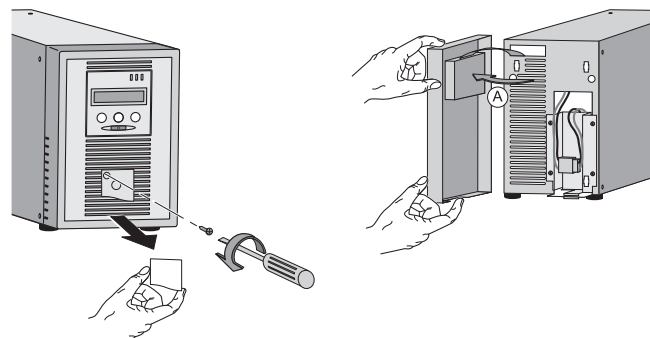

A - Verwijder het voorpaneel
naast de UPS.

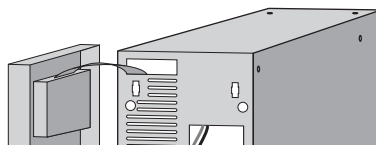

B - Koppel het accublok
connectoren uit elkaar te
aan de kabels trekken).

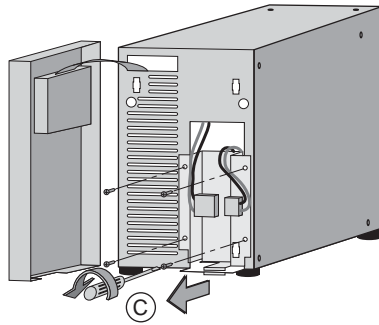

C - Verwijder de
van de metalen

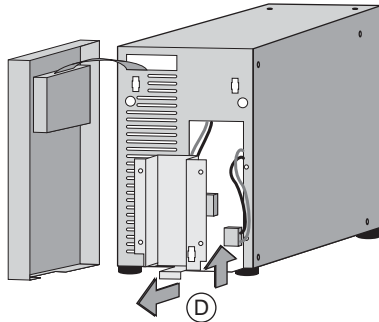

D - Verwijder de

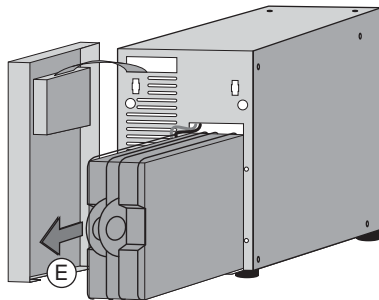

E - Trek aan de
uit het toestel te
accublok.

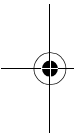

Plaatsen van de nieuwe accumodule

Voer bovenstaande handelingen in omgekeerde volgorde uit.



- ▮ Gebruik met het oog op de veiligheid en optimale prestaties alleen accu-elementen die geleverd.
- ▮ Druk bij het aansluiten de connectoren goed in elkaar.



5. Onderhoud

5.3 Onderhoud van een UPS met een HotSwap MBP-module

Modèle RT

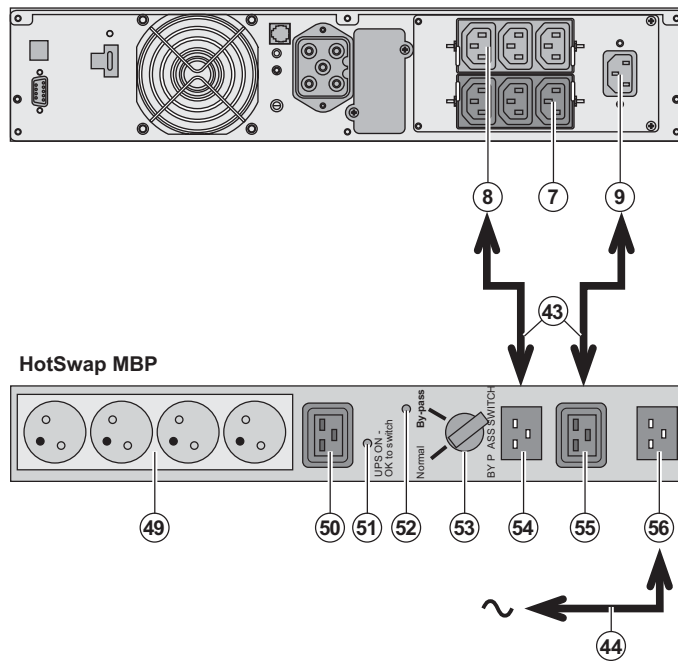

De **HotSwap MBP**-module maakt het mogelijk om de UPS mogelijk te maken voor de elektrische apparatuur (bijvoorbeeld de aangesloten apparatuur). (functie).

Onderhoud:

1 - Zet schakelaar (**53**) op de positie "By-pass" en het rode lampje (**52**) van de **HotSwap MBP**-module gaat branden om aan te geven dat de UPS rechtstreeks op het elektriciteitsnet wordt gevoed. 2 - Schakel de UPS uit door de voorkeursknop (**27**) aan de voorkant van de UPS te drukken: het lampje (**51**) van de "By-pass switch" gaat uit, de UPS wordt afgekoppeld en vervangen.

Terug naar normaal bedrijf

1 - Controleer of de UPS rechtstreeks op het elektriciteitsnet is aangesloten op de **HotSwap MBP**-module.

2 - Schakel de UPS in door de voorkeursknop (**27**) op de voorkant van de UPS te drukken: het lampje (**51**) van de "By-pass switch" gaat branden op de **HotSwap MBP**-module (zo niet, dan is er een probleem met de aansluiting van de **HotSwap MBP**-module op de UPS).

3 - Zet de schakelaar (**53**) op de positie "Normal" en het rode lampje (**52**) van de **HotSwap MBP**-module gaat uit.

4 - De aangesloten apparatuur wordt weer gevoed en beveiligd door de UPS.

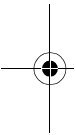



5.4 Trainingscentrum



Om volledig vertrouwd te raken met het gebruik van uw toestel van EATON en om op het h te kunnen verhelpen, bieden wij u een compleet programma met technische trainingen a Engels en het Frans gegeven.

For further information, please visit our website: www.eaton.com

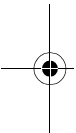



6. Bijlagen

6.1 Technische gegevens

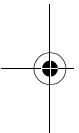
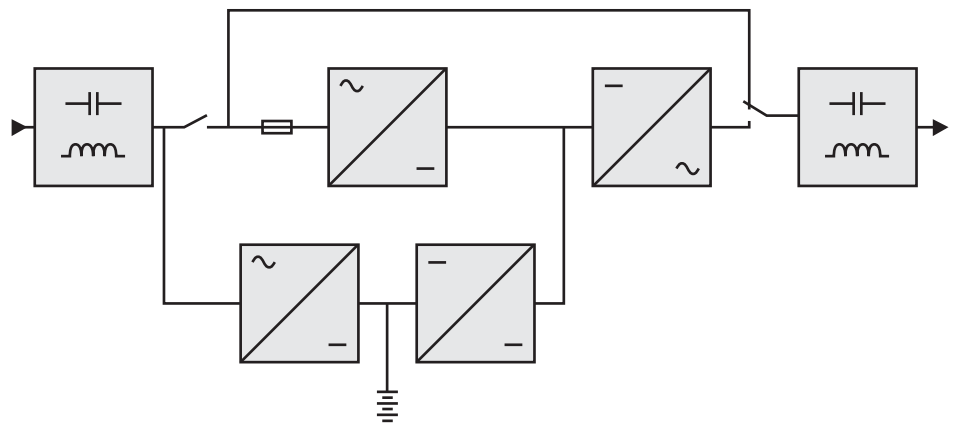

| | EX 700 | EX 1000 EX 1000 RT | EX 1500 EX 1500 RT |
|--------------------------------|--|--|--|
| Uitgangsvermogen | 700 VA / 630 W | 1000 VA / 900 W ⁽³⁾ | 1500 VA / 1350 W ⁽⁴⁾ |
| Elektrisch voedingsnet | Enkelfasig 100 / 120 / 140 / 160 à 284 V ⁽⁵⁾ 50/60 Hz (automatische keuze) > 0,95 | | |
| Gebruikersoutput | Enkelfasig 230 V ±3% ⁽⁶⁾ 50/60 Hz ±0,5% ⁽⁷⁾ < 4% op lineaire belasting, < 6% op niet-lineaire belasting 102% permanent, 130% 12s, > 130% 2s | | |
| ►Stroom | 3 A ⁽⁸⁾ | 4,3 A ⁽⁸⁾ | 6,5 A ⁽⁸⁾ |
| Accu | 2x12 V - 7 Ah, lood, vloeistofdicht, onderhoudsvrij | 3x12 V - 7 Ah, lood, vloeistofdicht, onderhoudsvrij | 3x12 V - 9 Ah, lood, vloeistofdicht, onderhoudsvrij |
| Omgeving | ►Geluidsniveau < 38 dBA ►Bedrijfstemperatuur 0°C tot 40°C ►Luchtvochtigheid 20% tot 90% (zonder condensatie) ►Lekstroom < 1,1 mA ►Opslagtemperatuur -25°C tot 40°C ►Hoogte 1000 m | | |
| Normen en certificering | ►Veiligheid IEC/EN 62040-1-1, EN 60950-1 (RD) ►Prestaties IEC/EN 62040-3 ►EMC EN 50091-2/IEC 62040-2 class B, IEC 61000-4-2/-3/-4/-6-8/-11, IEC 61000-3-2/-3 ►Opschriften | | |



6.2 Definities

| | |
|---|--|
| AC By-pass | Aftakking van het elektriciteitsnet die door de UPS wordt bediend. Het elektriciteitsnet kan rechtstreeks vanuit het elektriciteitsnet kan worden gevoed bij omkering van de wisselrichter. |
| Accutest | Interne test van de UPS om de toestand van de accu te controleren. |
| AC Normal | Dit is het elektriciteitsnet waarmee de UPS onder normale omstandigheden werkt. |
| Apparatuur | Toestellen of voorzieningen die op de uitgang van de UPS zijn aangesloten. |
| Belasting | Verhouding tussen het door de op de UPS aangesloten apparaat geleverde vermogen en het maximale vermogen dat de UPS kan leveren. |
| Drempelwaarde voor de waarschuwing "Accu bijna leeg" | Dit is een drempelwaarde voor het niveau van de accuspanning. Wanneer de accuspanning gemeten of de gebruiksduur van de accu binnenkort zal verstrijken, worden nodige maatregelen genomen met het oog op het weg nemen van de apparatuur. |
| FlexPDU | Module met contactdozen van de UPS ten behoeve van installatie van verschillende modules met verschillende contactdozen. |
| Frequentie-omzetter | Functie voor het omzetten van de frequentie van het elektriciteitsnet op de uitgang van de UPS (50 Hz -> 60 Hz of 60 Hz -> 50 Hz). |
| Gebruiksduur | De tijd gedurende welke de apparatuur wordt gevoed door de UPS als de accubedrijf draait. |
| HotSwap MBP | Module voor handmatig omschakelen van de UPS met het oog op het gebruik van verschillende modules met verschillende contactdozen. |
| Instellingen | Programmering van een aantal parameters die afwijkt van de standaardinstellingen van de fabriek is ingesteld. Een aantal functies van de UPS kan worden ingesteld met de Personal Solution-Pac -software, om ze beter af te stemmen op de behoeften van de gebruiker. |
| Opstarten op accu | Hiermee kan de spanning op de aangesloten apparatuur worden onderhouden als het elektriciteitsnet uitvalt. De UPS werkt dan alleen op de accu. |
| Programmeerbare contactdozen | Contactdozen die automatisch kunnen worden ontlast gedurende de laadcyclus van de accu (openingsvertraging instelbaar met de Personal Solution-Pac -software) en worden gebruikt voor twee groepen van twee programmeerbare contactdozen. |
| Softwarematig in- en uitschakelen van de wisselrichter | De beveiligingssoftware van computersystemen kan zo worden geïntegreerd met de UPS dat de in- en uitschakelprocedures van de UPS al dan niet wordt geïntegreerd met de beveiligingssoftware van de computer. |
| UPS | Uninterruptible Power Supply (ononderbroken stroomvoorziening) |
| Volledige ontlading | Ontlading van de accu tot voorbij het toegestane niveau, met het oog op het opladen van de accu tot gevolg. |

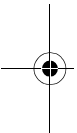

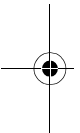



www.eaton.com

EX

700 – 1000

1000 RT –

EXB 1000

EXB 1000

Руководст

по устано

и эксплуа

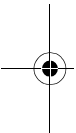

Pulsar Series

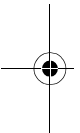



Мы благодарим вас за то, что вы выбрали одно из изделий компании EATON для обеспечения ваших применений.

Серия **EX** была разработана с учетом самых строгих требований. Чтобы наилучшим способом использовать все возможности вашего аппарата бесперебойно, рекомендуем вам тщательно ознакомиться с настоящим руководством.

Перед установкой аппарата **EX** внимательно прочтите его описание, которое содержит об инструкции по технике безопасности. Затем следовать инструкциям настоящего руководства.

Вы можете ознакомиться с предложениями компании EATON, а также с факультативными вариантами серии **EX** на нашем сайте Web : www.eaton.com. Вы можете также связаться с местным представителем компании EATON.

Охрана окружающей среды

Компания EATON ведет политику охраны окружающей среды. Наши изделия разработаны с учетом принципов экологической чистоты.

Вредные вещества

Настоящий аппарат не содержит ни хлорфторуглеродов (CFC), ни фторсодержащих углеводородов (HCFC), ни асбеста.

Упаковка

Отделить элементы упаковки друг от друга для облегчения обработки отходов и их утилизации.

- ▶ Картонная коробка содержит более 50% утилизованного картона.
- ▶ Мешки и пакеты изготовлены из полиэтилена.
- ▶ Материалы упаковки могут утилизироваться и отмечаются следующим идентификационным номером:

| Материал | Сокращенное название | Номер в символе |
|------------------------------|----------------------|-----------------|
| Полиэтилентерефталат | ПЭТ (PET) | 01 |
| Полиэтилен высокой плотности | ПЭВП (HDPE) | 02 |
| Поливинилхлорид | ПВХ (PVC) | 03 |
| Полиэтилен низкой плотности | ПЭНП (LDPE) | 04 |
| Полипропилен | ПП (PP) | 05 |
| Полистирол | ПС (PS) | 06 |

При захоронении материалов упаковки соблюдать действующие местные нормативные требования.

Конец срока службы

Компания EATON обязуется перерабатывать изделия в конце срока их службы в соответствии с местными нормативными требованиями, сотрудничая с предприятиями, занимающимися сбором и уничтожением подобных изделий по окончании срока их службы.

Аппарат

Настоящий аппарат изготовлен из утилизируемых материалов.

Его разборка и уничтожение должны производиться в соответствии с действующими местными требованиями, касающимися отходов.

По окончании срока службы данный аппарат должен быть отправлен в центр обработки отходов.

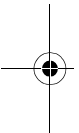



Вступление

Используемые графические символы



Обязательные инструкции.



Информация, рекомендации, помощь.



Визуальная индикация для наблюдения.



Выполняемое действие.



Звуковая сигнализация.

Следующие условные обозначения используются для представления световых индикаторов на и



Световой индикатор не горит.



Световой индикатор горит.



Световой индикатор мигает.

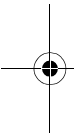

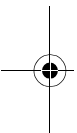

1. Презентация

- 1.1 **Стандартные исполнения**
 - Вертикальное исполнение
 - Исполнение для установки в стойку
- 1.2 **Задние панели**
 - EX 700 / 1000 / 1500
 - EX 1000 RT / 1500 RT.....
 - EX EXB (факультативный блок аккумуляторной батареи)
 - EX EXB RT (факультативный блок аккумуляторной батареи)
- 1.3 **Панель визуализации и управления**

2. Установка

- 2.1 **Распаковка и проверка содержимого**.....
- 2.2 **Установка модели RT в вертикальном положении**
- 2.3 **Установка модели RT в стойку**
- 2.4 **Порты связи**.....
 - Соединение порта связи RS-232 или USB (факультативно).....
 - Установка плат связи (по спецзаказу)
- 2.5 **Распределение выводов порта связи**
- 2.6 **Соединения с блоком FlexPDU (Power Distribution Unit)**
- 2.7 **Соединения с блоком HotSwap MBP**
- Работа блока HotSwap MBP
- 2.8 **Соединение АБП без блока FlexPDU или HotSwap MBP**.....

3. Эксплуатация

- 3.1 **Пуск в действие и работа в нормальном режиме**.....
- 3.2 **Работа от аккумуляторной батареи**
- 3.3 **Восстановление напряжения сети**.....
- 3.4 **Отключение АБП**.....
- 3.5 **Использование функций дистанционного управления АБП**.....

4. Доступ к функциям измерения и персонализации

- 4.1 **Структура дисплея**.....
- 4.2 **Доступ к функциям измерения**.....
- 4.3 **Персонализация с панели управления**.....
- 4.4 **Персонализация с помощью внешнего программного обеспечения**.....

5. Техобслуживание

- 5.1 **Неисправности**
- Неисправности АБП, оборудованного блоком HotSwap MBP
- 5.2 **Замена блока батареи**
- Напоминание о правилах по технике безопасности:
- Демонтаж блока батареи
- Установка нового блока батареи
- 5.3 **Техобслуживание АБП, оборудованного блоком HotSwap MBP**
- 5.4 **Учебно-тренировочный центр**.....

6. Приложения

- 6.1 **Технические характеристики**
- 6.2 **Глоссарий**



1. Презентация

1.1 Стандартные исполнения

Вертикальное исполнение

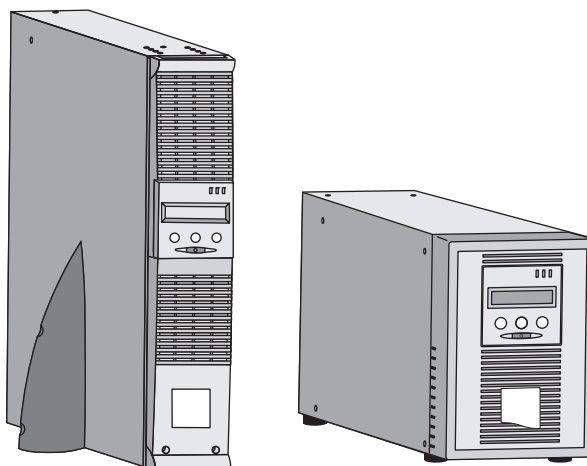

| Размеры в мм (выс. х шир. х глуб.) |
|------------------------------------|
|------------------------------------|

| |
|--------|
| EX 700 |
|--------|

| |
|---------|
| EX 1000 |
|---------|

| |
|------------|
| EX 1000 RT |
|------------|

| |
|---------|
| EX 1500 |
|---------|

| |
|------------|
| EX 1500 RT |
|------------|

| |
|--------|
| EX EXB |
|--------|

| |
|-----------|
| EX EXB RT |
|-----------|

| Масса в кг |
|------------|
|------------|

| |
|--------|
| EX 700 |
|--------|

| |
|---------|
| EX 1000 |
|---------|

| |
|------------|
| EX 1000 RT |
|------------|

| |
|---------|
| EX 1500 |
|---------|

| |
|------------|
| EX 1500 RT |
|------------|

| |
|--------|
| EX EXB |
|--------|

| |
|-----------|
| EX EXB RT |
|-----------|

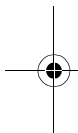

Исполнение для установки в стойку

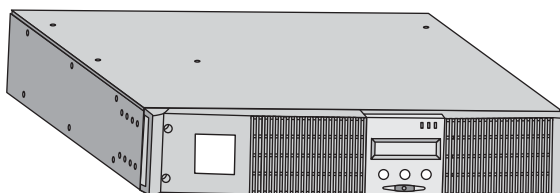



1.2 Задние панели

EX 700 / 1000 / 1500

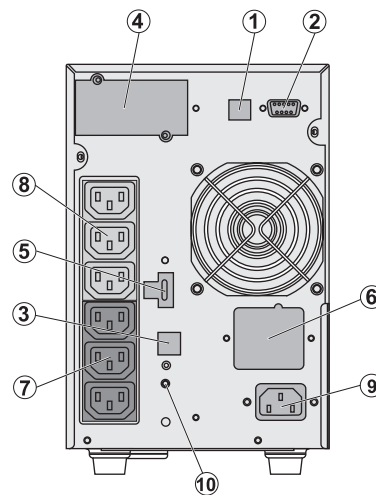

- (1) Порт связи UTP
- (2) Порт связи RJ45
- (3) Разъем для PoE
- (4) Паз для фактора
- (5) Разъем для PoE
- (6) Разъем для PoE
- (7) Группа из 3-х разъемов для PoE
- (8) Группа из 3-х разъемов для PoE
- (9) Разъем для PoE
- (10) Световой индикатор инверсии фазы и электропитания

EX 1000 RT / 1500 RT

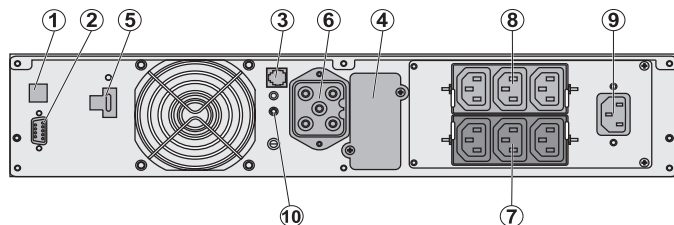

EX EXB (факультативный блок аккумуляторной батареи)

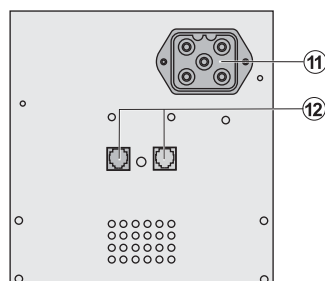

- (11) Разъемы для аккумуляторной батареи
- (12) Разъемы для PoE



1. Презентация

EX EXB RT (факультативный блок аккумуляторной батареи)

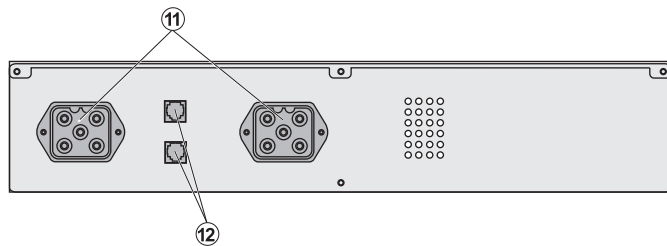

1.3 Панель визуализации и управления

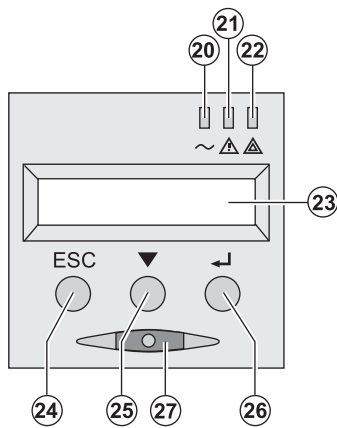

- (20) Световой индикатор оборудования
- (21) Световой индикатор пониженном режиме
- (22) Световой индикатор оборудования
- (23) Буквенно-цифровой
- (24) Кнопка прекращения
- (25) Кнопка прокрутки
- (26) Кнопка подтвержден
- (27) Кнопка включения/выключения (ON/OFF) АБП и выходн

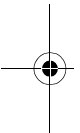



2.1 Распаковка и проверка содержимого

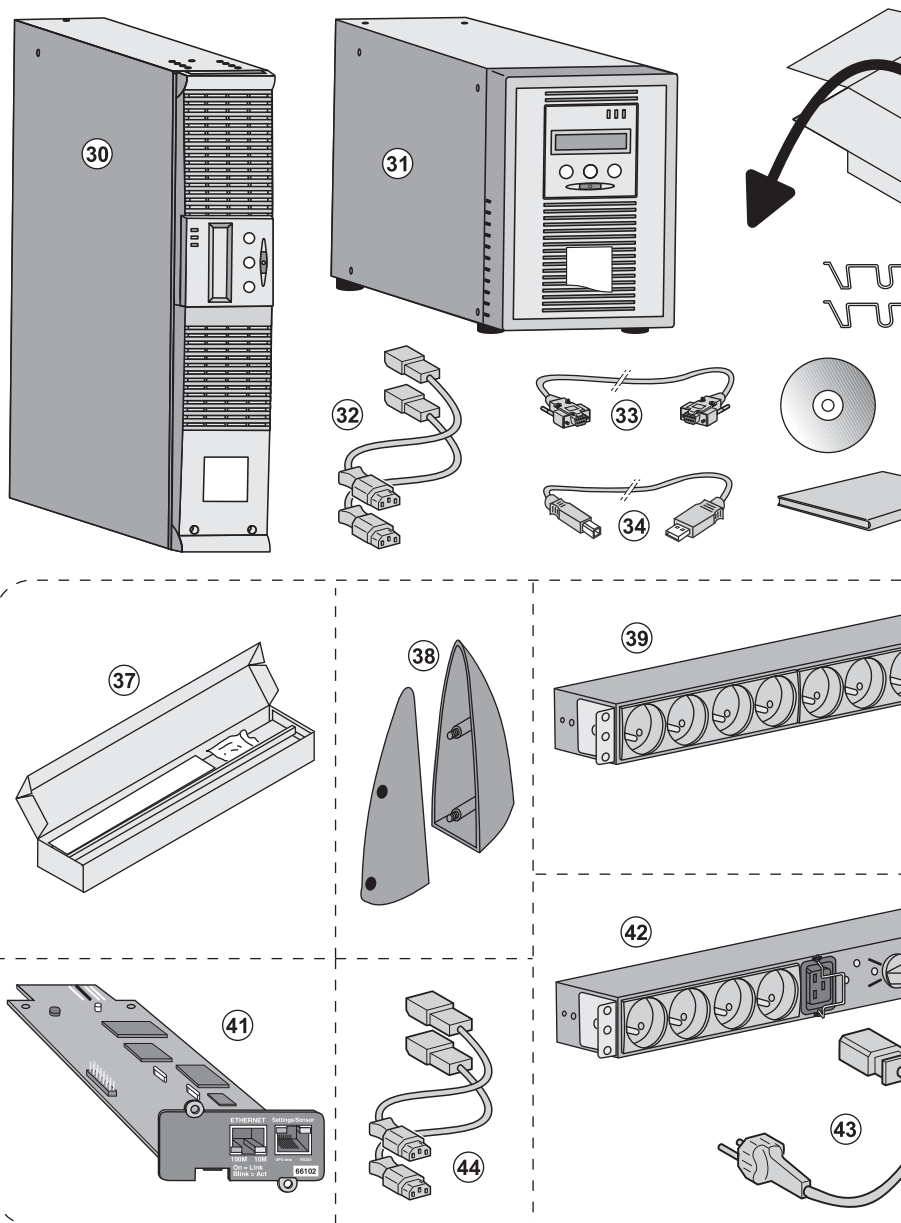

(30) АБП EX 700, 1000, 1500

(31) АБП EX 1000 RT, 1500 RT

(32) 2 шнура для подключения оборудования

(33) Кабель связи RS-232

(34) Кабель связи USB

(35) Система фиксации шнуров питания

оборудования (только модель RT)

Элементы, поставляемые в за-
или факультативно:

(37) Набор для монтажа в стойку

(38) 2 ножки для удержания в вер-
(только модель RT)

(39) Блок FlexPDU (факультатив-

(40) Шнур для соединения блока



2. Установка

2.2 Установка модели RT в вертикальном положении

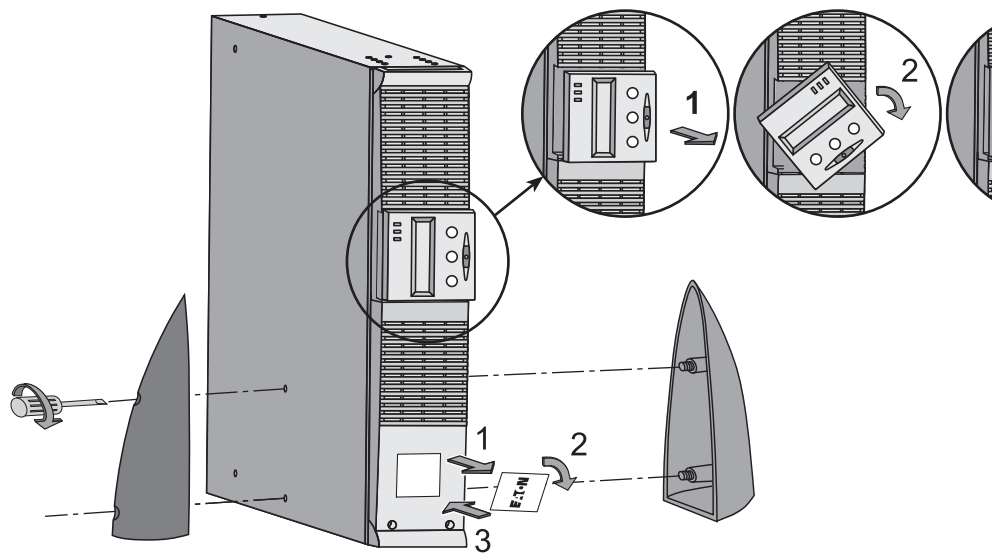

2.3 Установка модели RT в стойку

Рекомендуется установить блок или блоки аккумуляторной батареи EXB как можно ниже в стойку, а модель RT установить над ними АБП.

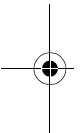

Для установки блока на рельсы выполнить пункты с 1 по 4.

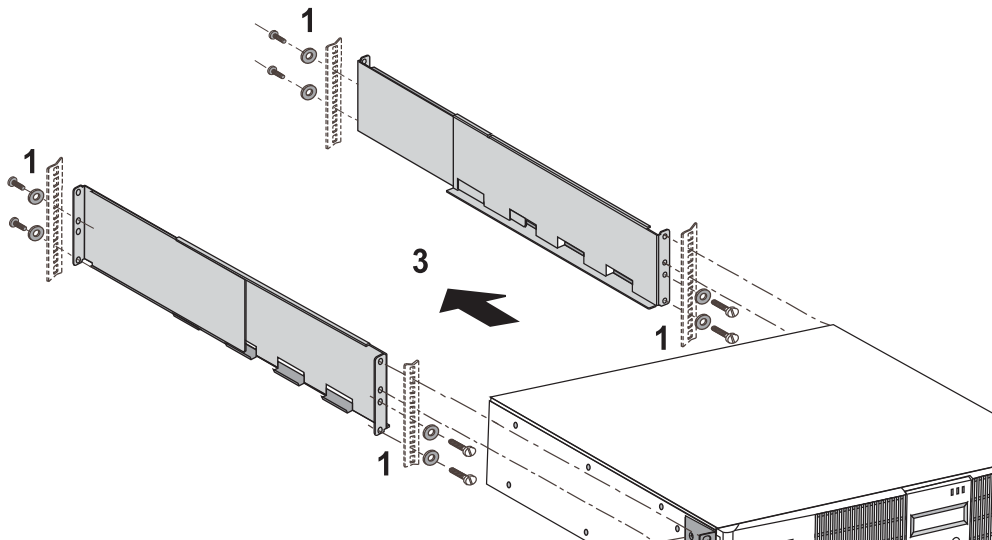



2.4 Порты связи

Соединение порта связи RS-232 или USB (факультативно)



Порты связи RS-232 и USB не могут работать одновременно.



Вертикальная модель

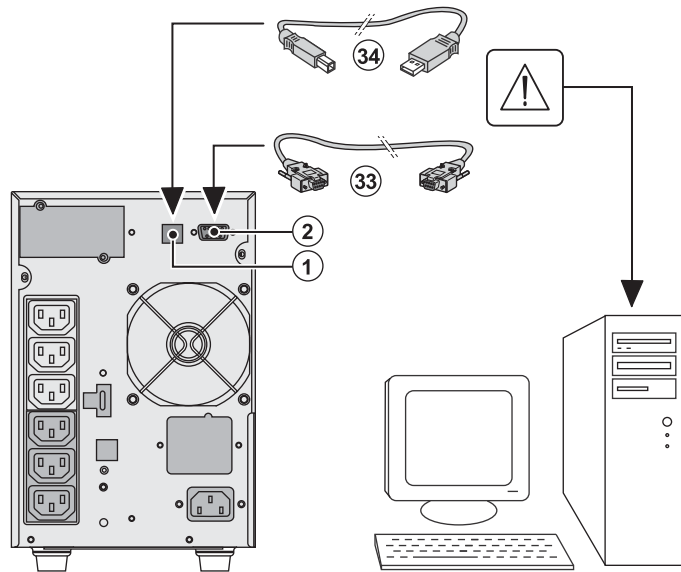

1 - Подсоединить кабель RS-232 (33) к порту RS-232 (2) АБП или USB (34) к порту USB (1) АБП.

2 - Соединить устройство с компьютером с помощью кабеля RS-232 (2) АБП.

Начиная с этого момента, устройство будет вести диалог с компьютером с обеспечением автоматического управления, перемещения и обеспечения безопасности EATON.

Модель RT

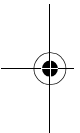
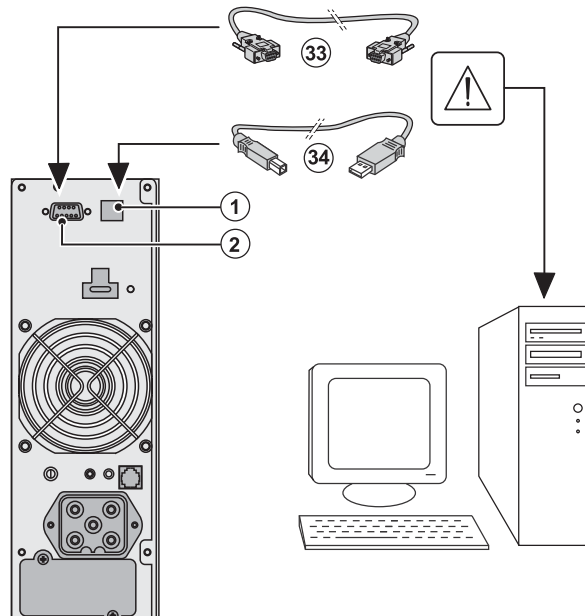

2. Установка

Установка плат связи (по спецзаказу)



Вертикальная модель

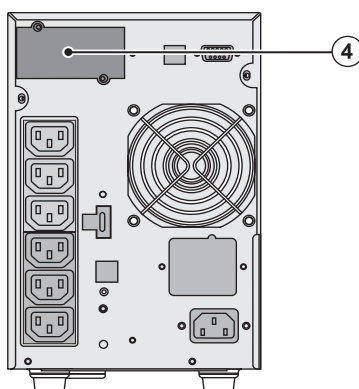

Модель RT

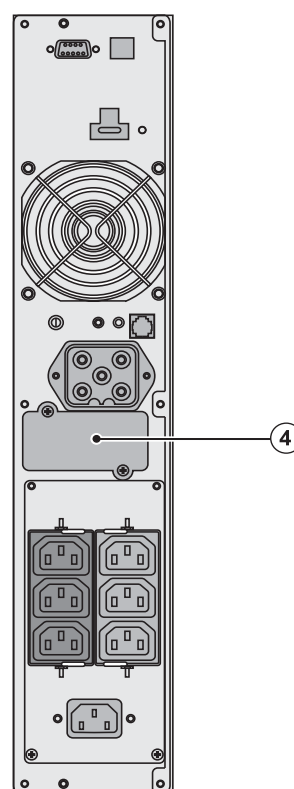

Для установки плат связи необходимо выключить питание (4): Паз для установки платы находится в ограниченном доступе.

- 1 - Снять с АБП крышку, которая крепится винтами.
- 2 - Вставить плату в паз, предусмотренный для ее установки.
- 3 - Закрепить крышку.

2.5 Распределение выводов порта связи (2)

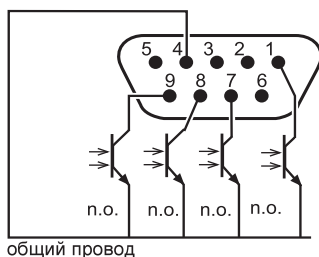

- ▶ Выводы 2, 3, 5 и 6: не используются
- ▶ Вывод 1: работа на автоматическом байпассе
- ▶ Вывод 4: общий провод пользователя
- ▶ Вывод 7: предупредительный сигнал конца автономной работы
- ▶ Вывод 8: потребители пользователя защищены
- ▶ Вывод 9: работа от батареи

п.о.: замыкающий контакт

Когда сигнал находится в активном состоянии, замыкается контакт между общим проводом и соответствующего сигнала.

Характеристики контактов (оптроны)

- ▶ Напряжение: 10 В пост. тока макс.
- ▶ Ток: 10 мА макс.
- ▶ Мощность: 0,1 Вт



2.6 Соединения с блоком FlexPDU (Power Distribution Unit, т. е. Блок питания) (по спецзаказу)

Модель RT

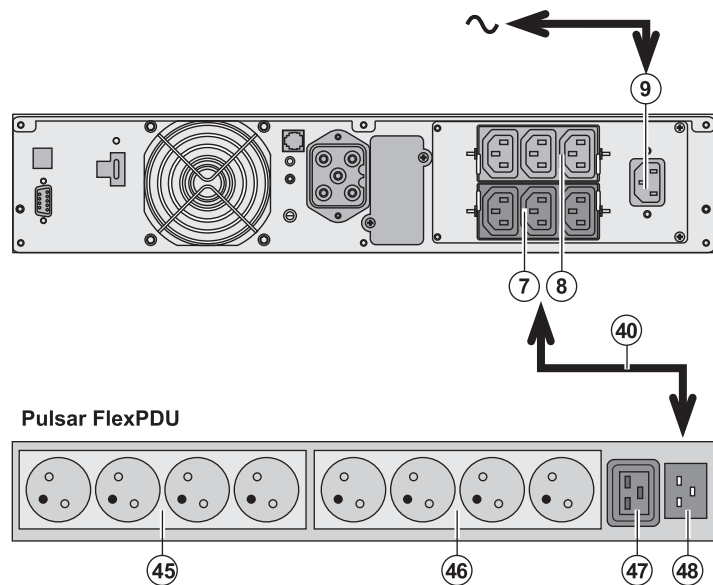

1 - Соединить входной кабель с сетью электропитания. Кабель должен быть защищен от перенапряжения.

2 - Соединить входной кабель электропитания блока с выходным разъемом FlexPDU с помощью поставленной в комплект поставки кабелей 10 А/16 А. Этот кабель имеет красную маркировку.

3 - Соединить оба блока (45), (46) и (47) блока с выходными разъемами FlexPDU. В зависимости от модели FlexPDU.

4 - Зафиксировать блок в установленном положении с помощью винтов и фланцев разъема.

2.7 Соединения с блоком HotSwap MBP (по спецзаказу)

Блок HotSwap MBP обеспечивает техобслуживание и, при необходимости, замену АБП так, чтобы это не повлияло на электропитание соединенного с ним оборудования (функция HotSwap).

Модель RT

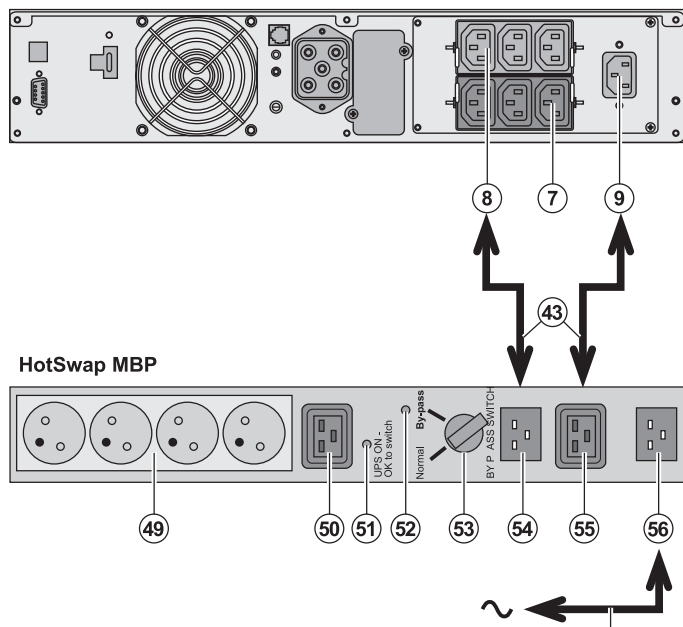

1 - Соединить входной кабель HotSwap MBP с сетью электропитания с помощью поставленной в комплект поставки кабелей.

2 - Соединить входной кабель электропитания АБП (Input) (Вход АБП) блока с выходными разъемами HotSwap MBP с помощью поставленной в комплект поставки кабелей (43). Этот кабель имеет синюю маркировку.

3 - Соединить один из выходных АБП (8) с разъемом HotSwap MBP (54) блока с помощью поставленной в комплект поставки кабелей. Этот кабель имеет синюю маркировку.

Для питания блока HotSwap MBP при соединении с АБП используйте поставленные в комплект поставки кабели 10 А FR/16 А (№ 68439).

В случае питания блока HotSwap MBP с помощью блока электропитания FlexPDU...

2. Установка

Работа блока HotSwap MBP

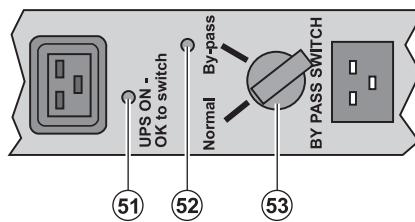

Блок **HotSwap MBP** имеет переключатель (53) на 2-х позициях: **Normal** (Нормальное): оборудование получает питание от АБП. **By-pass** (Байпас): оборудование получает питание от сети.

Пуск в действие АБП с блоком HotSwap MBP

- 1 - Убедиться, что АБП правильно соединен с блоком **HotSwap MBP**.
- 2 - Установить переключатель (53) в положение «Normal» (Нормальное).
- 3 - Включить АБП, нажав на кнопку включения/выключения (27) на передней панели АБП. Оборудование будет получать питание от АБП.

На блоке **HotSwap MBP** загорается световой индикатор (51) «UPS ON – OK to switch» (АБП Вкл. – готов).

Тест блока HotSwap MBP

- 1 - Установить переключатель (53) в положение «By-pass» и убедиться, что оборудование остается в рабочем состоянии.
- 2 - Вновь установить переключатель (53) в положение «Normal».

2.8 Соединение АБП без блока FlexPDU или HotSwap MBP



Убедиться, что данные на паспортной табличке с задней стороны аппарата соответствуют требованиям электропитания, а также фактическому потреблению каждой единицы оборудования.

Вертикальная модель

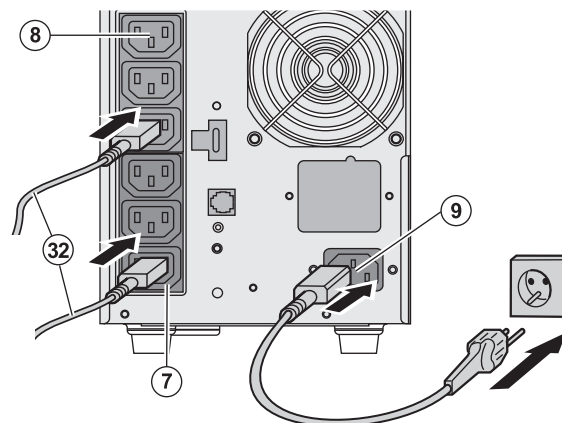

- 1 - Соединить входной разъем (8) с сетью с помощью шнура (32). Оборудование, которое должно быть защищено.
- 2 - Подсоединить оборудование к выходному разъему (7) с помощью шнура (32). Рекомендуется подсоединять приоритетное оборудование к разъему (8), а неприоритетное – к разъему (7), которые могут программироваться (1 и 2).



Для заказа или программирования разъемов использовать управление энергией коммутатора EATON.

Модель RT

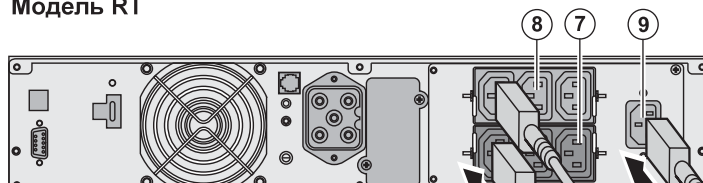



3.1 Пуск в действие и работа в нормальном режиме



При первом пуске наличие питания от сети необходимо для обнаружения возможной ошибки. Аппарат может запускаться при отсутствии питания от сети.

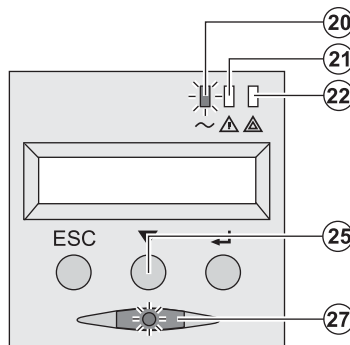

Нажать на кнопку (27) и удерживать ее пр
 ► Зуммер издает короткий звуковой сигнал. Световые индикаторы одновременно загораются.
 ► Затем зуммер издает 2 коротких звуковых сигнала. Это сигнал автоматического теста, затем подсветка кнопки (27) загорается, сигнализируя наличие питания.



Подсоединенное оборудование защищено от перенапряжения
 ► Световой индикатор (20) горит.
 Если горит световой индикатор (22), это означает неисправность (см. главу «Неисправности»).
 ► В режиме нормальной работы кнопка (25) используется для считывания измерений, выполненных на АБП. Кнопка (25) переключает электропитание, режим работы, емкость аккумулятора (заводской номер АБП).

Персонализация АБП



Если предусматривается персонализация АБП, рекомендуется войти в режим персонализации. Войти в этот режим можно с помощью кнопок на панели управления или через программу **Solution-Pac** для Windows, которое имеется на компакт-диске **Solution-Pac** компании Eaton.

3.2 Работа от аккумуляторной батареи

Переход на батарею

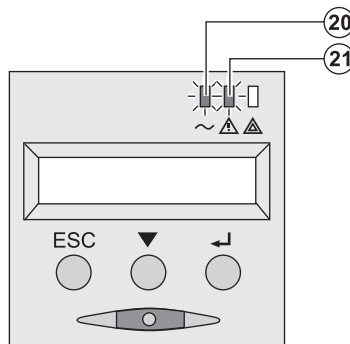

► Если исчезнет напряжение сети, подсоединенное к АБП оборудование продолжает получать питание от АБП. Показатель заряда берется от аккумуляторной батареи.
 ► Световые индикаторы (20) и (21) горят.
 ► Каждые 10 секунд дается короткий аварийный сигнал.

Подсоединенное к АБП оборудование защищено от перенапряжения
 от аккумуляторной батареи.

На дисплее указывается оставшаяся мощность автономной работы батареи.

Устанавливаемый порог сигнала конца автономной работы батареи

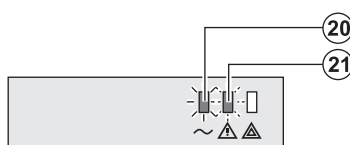

► Световые индикаторы (20) и (21) горят.
 ► Каждые 3 секунды дается короткий аварийный сигнал.

3. Эксплуатация

Конец автономной работы батареи



- ▶ Все световые индикаторы гаснут.
- ▶ Звуковой аварийный сигнал отсутствует.



АБП полностью отключен.

3.3 Восстановление напряжения сети

После исчезновения напряжения сети АБП автоматически перезапускается при его восстановлении (если функция не была деактивирована при персонализации АБП), и оборудование вновь получает питание.

3.4 Отключение АБП

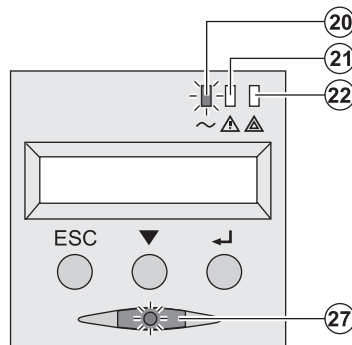

Нажать на кнопку (27) и удерживать ее более 2 сек.

Соединенное с АБП оборудование больше не питается.

3.5 Использование функций дистанционного управления АБП

АБП **Pulsar** имеет две функции дистанционного управления на выбор.

- ▶ **RPO** (Remote Power Off, т. е. Дистанционное выключение питания): это функция дистанционного выключения питания, которая позволяет выключать все оборудование, соединенное с АБП, с помощью выносного контакта. Перезапуск АБП требует ручного вмешательства.
- ▶ **ROO** (Remote ON/OFF, т. е. Дистанционное ВКЛ./ВЫКЛ.): это функция дистанционного включения/выключения, которая разблокирует выносную кнопку (27).

Эти функции обеспечиваются размыканием контакта, который включается между соответствующими контактами разъема (5) на передней панели АБП (см. иллюстрации ниже).



Модель RT

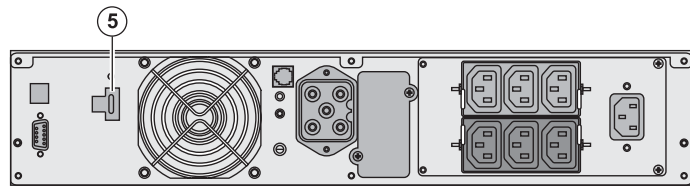

Вертикальн

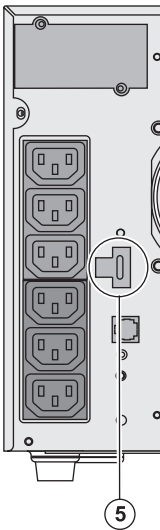

Подсоединение и тест команд дистанционного управления



- 1 - Убедиться, что АБП выключен и сеть электропитания отсоединена.
- 2 - Снять разъем (5), отвинтив винты.
- 3 - Подсоединить герконовый контакт замыкающего типа с развязкой (60 В пост. тока/30 В переменного тока) сечением кабеля 0,75 мм² между двумя выводами разъема (5) – см. иллюстрацию.

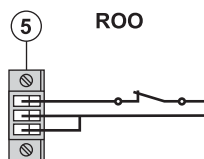

Контакт разомкнут: выключение АБП
 Контакт замкнут: включение АБП (АБП соединен с сетью, и нап

Примечание. Команда местного включения/выключения с помощью кнопки (27) имеет приоритет по отношению к дистанционной команде.

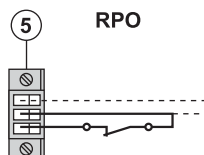

Контакт разомкнут: выключение АБП
 Чтобы вернуться к нормальной работе, деактивировать внешний контакт дистанционного управления (27) и перезапустить АБП кнопкой (27).

- 4 - Вставить разъем (5) в его гнездо на передней панели АБП.
- 5 - Подсоединить и перезапустить АБП согласно вышеописанным процедурам.
- 6 - Для проверки этой функции активировать внешний контакт дистанционного управления (27).



Внимание! Этот разъем должен соединяться исключительно с цепями уровня TBTS (Taux de Sécurité, т. е. Очень низкое безопасное напряжение).



4. Доступ к функциям измерения и персонализации

4.1 Структура дисплея

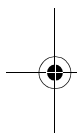

4.2 Доступ к функциям измерения

Последовательное нажатие на кнопку прокрутки (25) позволяет получить доступ к состояниям и к аварийным сигналам, а также к функциям измерения напряжения, тока, частоты, отдаваемой мощности и продолжительности автономной работы батареи.

4.3 Персонализация с панели управления

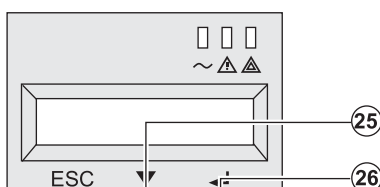

- ▶ Последовательно нажимать на кнопку прокрутки (25) и подтвердить выбор, чтобы вывести на дисплей меню персонализации.
- ▶ Кнопка подтверждения (26) позволяет получить доступ к различным функциям.
- ▶ И наконец, подтвердить свой выбор, вновь нажав на кнопку подтверждения (26).



4. Доступ к функциям измерения и пер

Персонализация выхода

| Функция | Заводская установка | Другой выбор | Коммент |
|---|---|--|-----------|
| Выходное напряжение ⁽¹⁾ | 230 В пер. тока | 200/208/220/240/250 В пер. тока | |
| Преобразователь частоты ⁽¹⁾ | Неактивная | Активная | Подсоедин |
| Выходная частота ⁽¹⁾ | Автоматический выбор | 50/60 Гц | Может вы |
| Переключение на обходную сеть электропитания ⁽¹⁾ | Если напряжение обходной сети электропитания переменным током в пределах допусков | Если напряжение обходной сети электропитания переменным током не в пределах допусков | |
| Уровень перегрузки ⁽¹⁾ | 100% | 30 / 50 / 70% | Аварийны |

(1) Эти параметры могут изменяться, только если АБП выключен (OFF).

Подробные комментарии имеются в программном обеспечении **Personal Solution-Pac**.

Персонализация включения/выключения (ON/OFF)

| Функция | Заводская установка | Другой выбор | Коммент |
|--|---------------------|--------------|------------|
| Пуск от батареи | Активная | Неактивная | |
| Автоматический перезапуск | Активная | Неактивная | Автоматиче |
| Энергосбережение | Неактивная | Активная | Если функц |
| Обнаружение инверсии фазы/нейтрали (SWF) | Неактивная | Активная | Если функц |

Персонализация батареи

| Функция | Заводская установка | Другой выбор | Коммент |
|---|---|---|------------|
| Тест батареи | Еженедельный | Отсутствие теста/ежедневный/ежемесячный | |
| Предупредительный сигнал конца автономной работы | 20% | От 0 до 100% | С шагом в |
| Выбор продолжительности автономной работы батареи | Автоматическое обнаружение числа блоков батареи | От 13 до 200А.ч | |
| Защита батареи от глубокого разряда | Активная | Неактивная | Если функц |

4.4 Персонализация с помощью внешнего программного обеспе



- Вставить в считывающее устройство компакт-диск **Solution-Pac**.
- На первом экране навигатора выбрать «Solution Point à Point» (Двухточечное решение) в программном обеспечении **Personal Solution-Pac** в соответствии с инструкциями на экране



5. Техобслуживание

5.1 Неисправности



Если световой индикатор (21) или (22) горит, это означает, что не имеется никаких неисправностей или аварийных сигналов.

Для отключения звукового аварийного сигнала использовать кнопку перехода (24).

| | Признак неисправности | Возможная причина | Средство устранения |
|---|--|---|---|
| 1 | АБП не включается, на алфавитно-цифровом дисплее сообщения: COLD START NOK (сбой включения в холодном состоянии) CHECK AC WIRING (проверить соединение с сетью) | Отсутствие напряжения сети, или сеть соединена с выходом АБП. | Проверить правильность подключения с сетью электропитания. |
| 2 | Световой индикатор (22) и световой индикатор SWF (11) на задней панели АБП горят. На алфавитно-цифровом дисплее сообщение: SITE WIR. FAULT (ошибка соединения с сетью) CHECK AC WIRING (проверить соединение с сетью) | Инверсия фазы входного питания. АБП не включается. | ► В случае электрических работ с заземленной нейтралью фаз отсоединить и поменять разъем сети (типа DIN) и вызвать электрика, чтобы соединения. ► В случае сети другого типа проверить функцию обнуления |
| 3 | Световой индикатор (22) горит, на алфавитно-цифровом дисплее сообщение: NO BATTERY (батарея отсутствует) CHECK CONNECTION (проверить соединения) | Батарея подсоединена неверно. | Проверить подсоединение (см. § 5.2 «Замена батареи») |
| 4 | Световой индикатор (22) горит, на алфавитно-цифровом дисплее сообщение: BATTERY FAULT (дефект батареи) SERV REQUIRED (вызвать электрика) | Был обнаружен дефект батареи. | Выполнить замену батареи (см. § 5.2 «Замена батареи») Обратиться в отдел технического обслуживания. |
| 5 | Световой индикатор (21) горит, на алфавитно-цифровом дисплее сообщение: OVERLOAD ALARM (сигнал перегрузки) REDUCE LOAD (уменьшить нагрузку) | Коэффициент перегрузки превышает запрограммированный уровень перегрузки или перегрузочную способность АБП. | Проверить значения мощности потребляемой подсоединенным оборудованием, и отключить неприоритетное оборудование. Проверить запрограммированный уровень перегрузки. |
| 6 | Световой индикатор (22) горит, на алфавитно-цифровом дисплее сообщения: LOAD UNPROTECTED (нагрузка не защищена) OUTPUT OVERLOAD (перегрузка выхода) | АБП перегружен. Подсоединенное оборудование получает питание прямо от сети через обходную линию. | Проверить значения мощности потребляемой подсоединенным оборудованием, и отключить неприоритетное оборудование. |
| 7 | Световой индикатор (22) горит, на алфавитно-цифровом дисплее сообщения: REDUCE LOAD (уменьшить нагрузку) RESTART UPS (вновь включить АБП) | Из-за повторных перегрузок АБП заблокирован в положении «Ву-pass». Подсоединенное оборудование получает питание прямо от сети. | Проверить значения мощности потребляемой подсоединенным оборудованием, и отключить неприоритетное оборудование. Выключить и вновь включить АБП вернуться в нормальный режим |
| 8 | Световой индикатор (22) горит, на алфавитно-цифровом дисплее сообщение: OVERLOAD FAULT (перегрузка) REDUCE LOAD (уменьшить нагрузку) | АБП автоматически выключен из-за значительной перегрузки. | Проверить значения мощности потребляемой подсоединенным оборудованием, и отключить неприоритетное оборудование. |
| 9 | Световой индикатор (22) горит, на алфавитно-цифровом дисплее сообщение: LOAD SHORT-CIRCUIT (КЗ нагрузка) | АБП автоматически выключен из-за короткого замыкания на выходе АБП. | Проверить установку (кабельные соединения) неисправного оборудования |

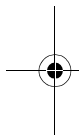



5. Техо

Неисправности АБП, оборудованного блоком HotSwap MBP



| | Признак неисправности | Возможная причина | Средс |
|----|---|---|---|
| 12 | Подсоединенное оборудование не получает питания, когда поворотный переключатель (49) блока HotSwap MBP находится в положении «By-pass». | <ul style="list-style-type: none"> ▶ Оборудование подсоединено к выходу АБП вместо подключения к блоку HotSwap MBP. ▶ Шнур питания от сети соединен со входом АБП вместо соединения с блоком HotSwap MBP. | Провери блоком M |
| 13 | Подсоединенное оборудование не получает питания, когда поворотный переключатель (49) блока HotSwap MBP находится в положении «Normal». | <ul style="list-style-type: none"> ▶ АБП выключен. ▶ Неверные соединения между АБП и блоком HotSwap MBP. | ▶ Вновь ▶ Прове и блоком |
| 14 | Подсоединенное оборудование не получает питания при исчезновении напряжения сети. | <ul style="list-style-type: none"> ▶ Поворотный переключатель (49) блока HotSwap MBP находится в положении «By-pass». ▶ Неверные соединения между АБП и блоком HotSwap MBP. | ▶ Устан (49) бло «Normal ▶ Прове блоком M |

В случае неисправности, вызвавшей выключение АБП, нажать на кнопку включения/выключения (27), чтобы кви

5.2 Замена блока батареи

Напоминание о правилах по технике безопасности:

Аккумуляторная батарея представляет риск поражения электрическим током и им
замыкания. При любой работе на элементах аккумуляторной батареи должны прини
предосторожности:

- ▶ Снять с рук часы, перстни, обручальные кольца, браслеты и любые другие мета
- ▶ Использовать инструмент с изолированной рукояткой.

Демонтаж блока батареи

Модель RT

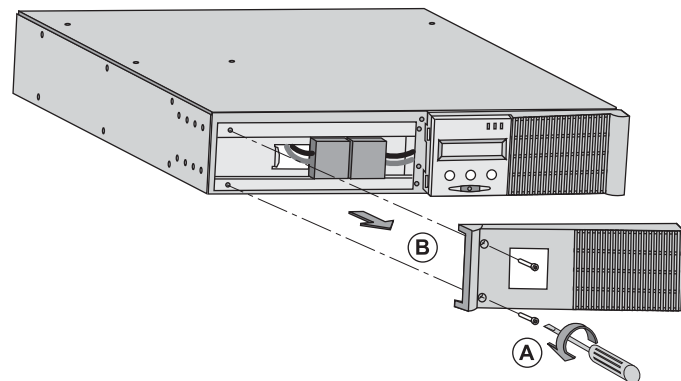

A - Отсоедини
передней пане
B - Снять эту п



5. Техобслуживание

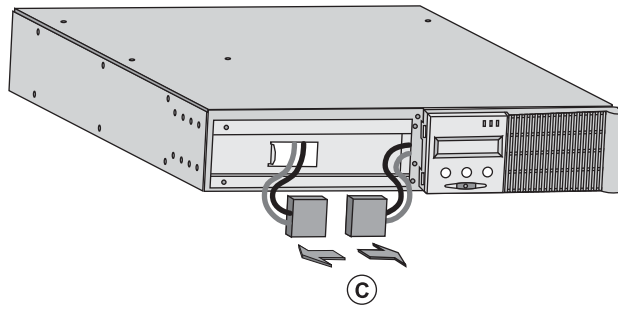

C - Отсоединить блок батареи от сервера, разъединив 2 разъема (затянуть за кабели).

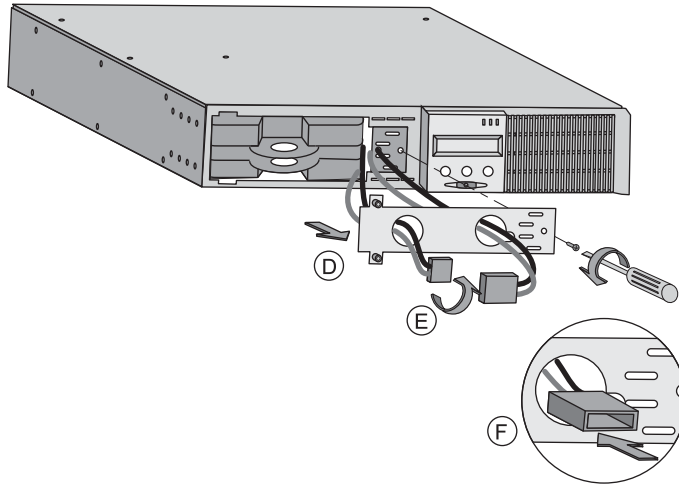

D - Снять защитную металлическую крышку батареи, отвинтив ее.
E - Повернуть разъем.
F - Пропустить разъем через отверстие.

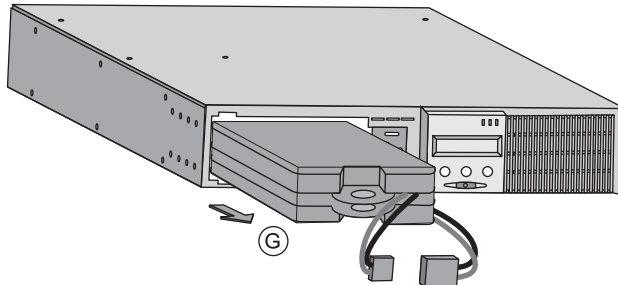
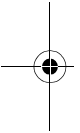

G - Вынуть блок батареи из сервера, потянув за пластмассовый язычок.

Вертикальная модель

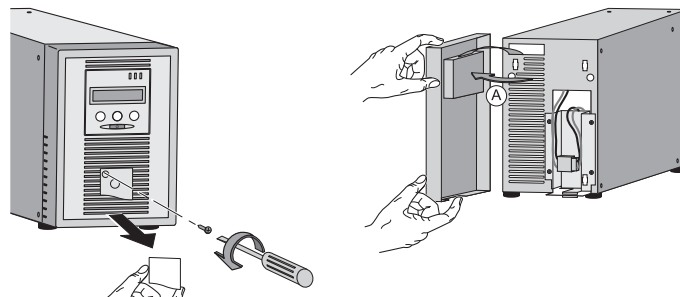

A - Снять переднюю панель сервера, отвинтив ее возле АБП.



5. Техоб

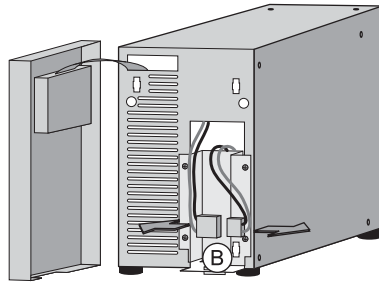

В – Отсоединит
разъединив 2 п
тянуть за кабел

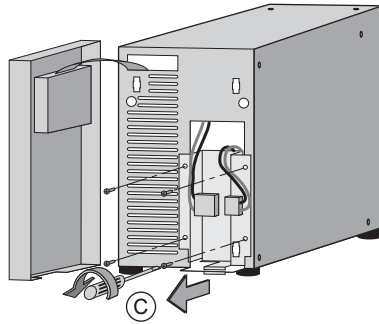

С – Снять 4 вин
металлическую

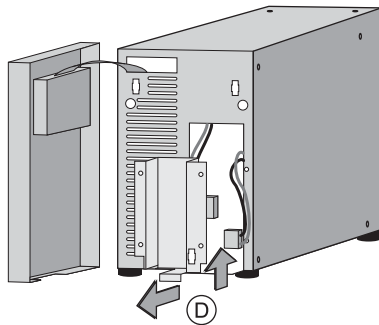

D – Снять защи

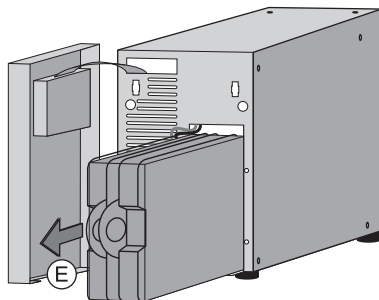

E – Вынуть бло
пластмассовый



5. Техобслуживание

5.3 Техобслуживание АБП, оборудованного блоком HotSwap MBP

Модель RT

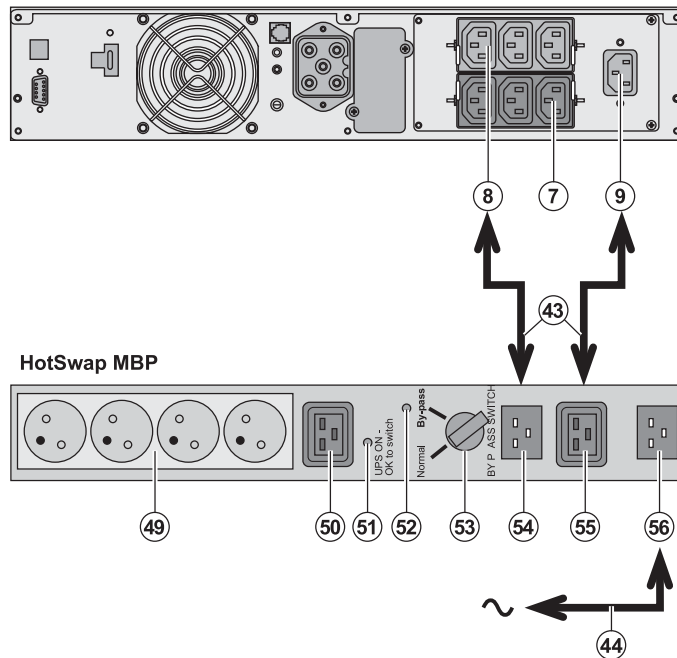

Блок **HotSwap MBP** обеспечивает возможность проведения техобслуживания и, при необходимости, замену АБП таким образом, что это не повлияло на электропитание оборудования, соединенного с ним оборудованием (функция **HotSwap**).

Техобслуживание

1 - Установить переключатель в положение «By-pass»: индикатор (52) блока **HotSwap MBP** загорается, указывая, что блок получает питание напрямую от сети.

2 - Выключить АБП, нажав кнопку включения/выключения на панели АБП: световой индикатор «UPS ON – OK to switch» загорается, что означает, что АБП может быть отключен и заменен.

Возврат к нормальной работе

1 - Убедиться, что АБП правильно соединен с блоком **HotSwap MBP**.

2 - Включить АБП, нажав кнопку включения/выключения на панели АБП: световой индикатор «UPS ON – OK to switch» загорается.

Если блок **HotSwap MBP** соединен неправильно, индикатор (52) блока **HotSwap MBP** не загорается.

3 - Установить переключатель в положение «Normal»: индикатор (52) блока **HotSwap MBP** гаснет.

4 - Блок АБП обеспечивает питание и защиту оборудования.

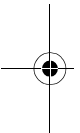



5. Техоб

5.4 Учебно-тренировочный центр



Для более подробного ознакомления с работой аппарата компании EATON и с техобслуживанием на высоком уровне мы предлагаем комплексную программу профессионально-технического обучения на русском и французском языках.

For further information, please visit our website: www.eaton.com

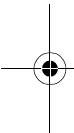



6. Приложения

6.1 Технические характеристики

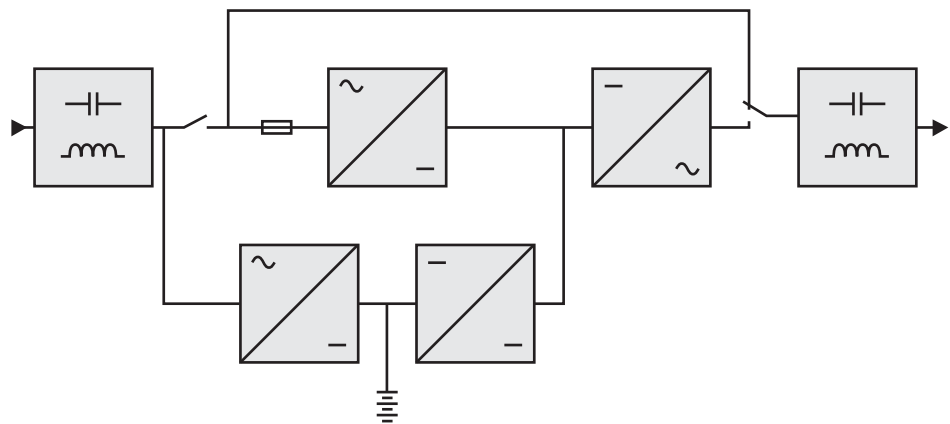

| | EX 700 | EX 1000 EX 1000 RT | EX 1500 EX 1500 RT |
|--|---|--|--|
| Выходная мощность | 700 В.А / 630 Вт | 1000 В.А / 900 Вт ⁽³⁾ | 1500 В.А / 1350 Вт ⁽⁴⁾ |
| Сеть электропитания <ul style="list-style-type: none"> ▸ Напряжение ▸ Частота ▸ Коэффициент мощности | Однофазное 100 / 120 / 140 / от 160 до 284 В ⁽⁵⁾ 50/60 Гц (автоматический выбор) > 0,95 | | |
| Выход для потребителя <ul style="list-style-type: none"> ▸ Напряжение ▸ Частота ▸ Гармоническое искажение (THDV) ▸ Допустимая перегрузка | Однофазное 230 В ± 3% ⁽⁶⁾ 50/60 Гц ± 0,5% ⁽⁷⁾ < 4% на линейной нагрузке, < 6% на нелинейной нагрузке 102% в постоянном режиме, 130% в течение 12 с, > 130% в течение 2 с | | |
| Ток | 3 А ⁽⁸⁾ | 4,3 А ⁽⁸⁾ | 6,5 А ⁽⁸⁾ |
| Аккумуляторная батарея | 2 элемента x 12 В – 7 А.ч свинцовых, герметичных, не требующих техобслуживания | 3 элемента x 12 В – 7 А.ч свинцовых, герметичных, не требующих техобслуживания | 3 элемента x 12 В – 9 А.ч свинцовых, герметичных, не требующих техобслуживания |
| Условия окружающей среды <ul style="list-style-type: none"> ▸ Уровень шума ▸ Рабочая температура ▸ Относительная влажность ▸ Ток утечки ▸ Температура при хранении ▸ Высота над уровнем моря | < 38 дБА От 0°С до 40°С От 20% до 90% (без конденсации) 1,1 мА От - 25°С до 40°С 1000 м | | |
| Стандарты и сертификация <ul style="list-style-type: none"> ▸ Безопасность ▸ Рабочие характеристики ▸ ЭМС ▸ Маркировка | IEC/EN 62040-1-1, EN 60950-1 (RD) IEC/EN 62040-3 EN 50091-2/IEC 62040-2 класс B, IEC 61000-4-2/-3/-4/-6-8/-11, IEC 61000-3-2/-3 CE, TÜV/GS, UL, cUL, CB report | | |

(1) Возможность расширения батареи для АБП EX 1000 и EX 1500.

(2) Возможность расширения батареи для АБП EX 1000 RT и EX 1500 RT.

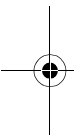



6.2 Глоссарий

| | |
|--|--|
| АБП | Аппарат бесперебойного питания. |
| Байпас пер. тока | Обходная линия сети электропитания, управляемая от АБП и обеспечивающая питание оборудования от сети в случае перегрузки или нарушения работы аппарата питания. |
| Глубокий разряд | Разряд аккумуляторной батареи ниже допустимого предела, вызывающий повреждение батареи. |
| Запуск от батареи | Позволяет осуществлять включение оборудования, соединенного с АБП, сети электропитания. АБП при этом работает только от батареи. |
| Коэффициент нагрузки | Отношение мощности, потребляемой соединенным с АБП оборудованием, к мощности, которую может обеспечить АБП. |
| Нормальная линия пер. тока | Нормальная линия питания АБП от электросети. |
| Оборудование | Аппараты или устройства, соединенные с выходом АБП. |
| Персонализация | Программирование некоторых параметров со значениями, отличными от заводских, на выходе с завода-изготовителя. Некоторые функции АБП могут быть изменены с помощью программного обеспечения Personal Solution-Pac с целью наилучшего удовлетворения потребностей пользователя. |
| Порог предупредительного сигнала конца автономной работы батареи | Предельное значение уровня напряжения батареи, позволяющее обнаружить ее автономной работы и принять необходимые меры, касающиеся близкого к концу автономной работы оборудования. |
| Преобразователь частоты | Функция, позволяющая преобразовывать частоту сети электропитания. АБП (50 Гц -> 60 Гц или 60 Гц -> 50 Гц). |
| Программируемые разъемы | Разъемы, которые могут быть автоматически разгружены в течение срока автономной работы батареи (выдержка времени отключения может задаваться программно с помощью программного обеспечения Solution-Pac). АБП имеет 2 группы по 2 программируемых разъема. |
| Программное включение/выключение АБП | Функция, разрешающая или запрещающая программному обеспечению оборудования запускать последовательности включения/выключения АБП. |
| Продолжительность автономной работы | Промежуток времени, в течение которого оборудование получает питание от аккумуляторной батареи. |
| Тест батареи | Внутренний тест АБП, позволяющий проверить состояние аккумуляторной батареи. |
| FlexPDU | Блок выходных разъемов АБП для установки в раму стойки. Имеются блоки, соответствующие различным типам разъемов. |
| HotSwap MBP | Блок ручного обхода АБП с целью техобслуживания. Имеются блоки, соответствующие различным типам разъемов. |

