



ИБП Eaton PW 9315-65 - Powerware 9315 Fixed Master Sync Control

Постоянная ссылка на страницу: <https://eaton-power.ru/catalog/powerware-9315/pw-9315-65/>



**Powerware®**

**9315**

Fixed Master  
Sync Control

---

INSTALLATION & OPERATION MANUAL

## **IMPORTANT SAFETY INSTRUCTIONS**

Instructions Importantes Concernant La Sécurité

### **SAVE THESE INSTRUCTIONS**

Conserver Ces Instructions

**This manual contains important instructions for your Uninterruptible Power Supply (UPS) system. You should follow these instructions during the installation and maintenance of the UPS, options, accessories, and batteries.**

Cette notice contient des instructions importantes concernant la sécurité.

This equipment has been tested and found to comply with the limits for a Class A digital device, pursuant to Part 15 of the FCC Rules. These limits are designed to provide reasonable protection against harmful interference when the equipment is operated in a commercial environment. This equipment generates, uses, and can radiate radio frequency energy and, if not installed and used in accordance with the instruction manual, may cause harmful interference to radio communications. Operation of this equipment in a residential area is likely to cause harmful interference in which case the user will be required to correct the interference at their own expense.

#### **WARNING**



**This is a product for restricted sales distribution to informed partners. Installation restrictions or additional measures may be needed to prevent disturbances.**

# Table of Contents

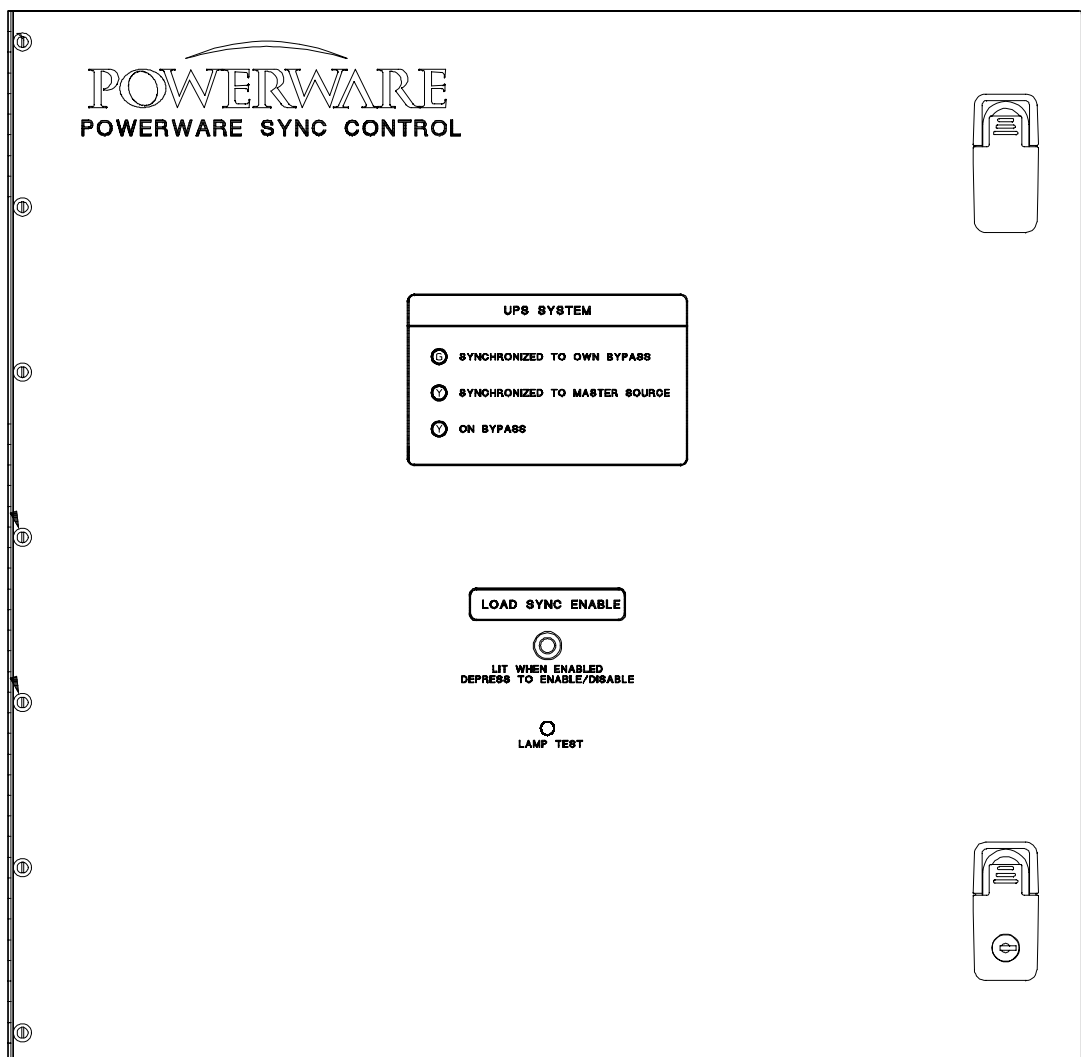
<b>Introduction</b> .....	<b>1</b>
Using This Manual .....	2
For More Information .....	2
Getting Help .....	3
<b>1 Getting Started</b> .....	<b>5</b>
Preparing the Site .....	5
Creating an Installation Plan .....	5
Environmental Considerations .....	6
Preparing for Wiring the Powerware Fixed Master Sync Control .....	6
Inspecting and Unpacking the Powerware Fixed Master Sync Control .....	6
<b>2 Installing the Powerware Sync Control</b> .....	<b>7</b>
<b>3 Powerware Fixed Master Sync Control Operation</b> .....	<b>17</b>
Preliminary Checks and Startup for SBM Systems Equipped with a Powerware Fixed Master Sync Control .....	17
Understanding Fixed Master Sync Control Operation .....	18
Operation .....	20
Customer Monitoring .....	22
Maintenance Operations .....	23
<b>Appendix A</b> .....	<b>A-1</b>

# List of Figures

Figure 1.	Powerware Fixed Master Sync Control .....	1
Figure 2.	Powerware Fixed Master Sync Control Interface Location for 30–80 kVA Single Module Powerware 9315 UPS System .....	8
Figure 3.	Powerware Fixed Master Sync Control Interface Location for 100–160 kVA Single Module Powerware 9315 UPS System ....	9
Figure 4.	Powerware Fixed Master Sync Control Interface Locations for 200–300 kVA Single Module Powerware 9315 UPS System ....	10
Figure 5.	Powerware Fixed Master Sync Control Interface Location for 400–500 kVA Single Module Powerware 9315 UPS System ....	11
Figure 6.	Powerware Fixed Master Sync Control Interface Location for 750 kVA Single Module Powerware 9315 UPS System .....	12
Figure 7.	Powerware Fixed Master Sync Control Interface Location for fPowerware Hot Sync–Capacity System with 1200 Amp SBM ..	13
Figure 8.	Powerware Fixed Master Sync Control Interface Location for Powerware Hot Sync–Capacity System with 2000 Amp SBM ...	14
Figure 9.	Location of (S)SBM Customer Interface Panel Terminal Blocks TB3, TB4, TB6 and TB7 .....	15
Figure 10.	Typical Control Wiring Termination Locations for the Powerware Fixed Master Sync Control .....	16
Figure 11.	Powerware Fixed Master Sync Control Block Diagram for a Powerware Hot Sync–Capacity System .....	18
Figure 12.	Synchronization Reference Control .....	20
Figure 13.	Powerware Fixed Master Sync Control Controls and Indicators .	21

# Introduction

The Powerware® Fixed Master Sync Control maintains the synchronization of the Powerware system's critical load outputs to a fixed master source. The master source can be a third party UPS, utility or another Powerware system. This facilitates the uninterrupted transfer of the load from one load bus to another by means of downstream dual source solid state transfer switches. Without the load sync option, the possibility exists for the two system output (critical load) buses to become out of phase with each other. This condition occurs if suitable bypass sources are not available, or if the bypass sources feeding each system are not in sync with each other. An example of this condition would be if the two systems are supplied by separate diesel generator sets, or if the bypass sources for the two systems are lost. Figure 1 shows the front view of the Sync Control.



**Figure 1. Powerware Fixed Master Sync Control**

## Using This Manual

---

This manual contains control enclosure dimensions and mounting information, control wiring requirements, and operation procedures for the Powerware Fixed Master Sync Control. The text uses these conventions:

- **Bold type** highlights important concepts in discussions, key terms in procedures, and menu options.
- *Italic type* highlights notes, references to other system manuals, references to other sections of this manual, and new terms where they are defined.
- Rectangular boxes containing bold type are warnings or cautions that pertain to the system or its electrical connections. This important information indicates possible dangers pertaining to personnel safety, equipment damage, critical load protection, or operational concerns.

Before installation of the Powerware Fixed Master Sync Control, read through each installation procedure.

## For More Information

---

For more information on the installation and operation of the UPS system and its accessories, refer to the following:

<b>164200252</b>	<b><i>Powerware® 9315 30–160 kVA UPS Operation</i></b>
<b>164201036</b>	<b><i>Powerware® 9315 200–300 kVA UPS Operation</i></b>
<b>164201119</b>	<b><i>Powerware® 9315 400/500 (300–500 kVA) UPS Operation</i></b>
<b>164201244</b>	<b><i>Powerware® 9315 500/750 (500–750 kVA) UPS Operation/Installation</i></b>

Each manual describes the UPS cabinet Control and Monitor Panels, and explains the functions of the UPS; discusses the standard features of the UPS and optional accessories; provides procedures for starting and stopping the UPS, and information about maintenance and responding to system events.

Also described are the RS–485 and RS–232 serial communications capabilities of the UPS; the two communications ports on the Customer Interface Panel inside the UPS and how to connect optional remote accessories to your UPS system; and provide information about enabling, disabling, and customizing building alarms.

<b>164200253</b>	<b><i>Powerware® 9315 30–80 kVA UPS Installation</i></b>
<b>164200292</b>	<b><i>Powerware® 9315 100–160 kVA UPS Installation</i></b>
<b>164201037</b>	<b><i>Powerware® 9315 200–300 kVA UPS Installation</i></b>
<b>164201118</b>	<b><i>Powerware® 9315 400/500 (300–500 kVA) UPS Installation</i></b>
<b>164201244</b>	<b><i>Powerware® 9315 500/750 (500–750 kVA) UPS Installation/Operation</i></b>

Each manual contains the following information: how to prepare the site and plan for installation, detailed step-by-step procedures for installing each component of your system, how to join cabinets in a line-up-and-match system, detailed illustrations of cabinets and optional accessories, including dimensions and connection points.

164201150

**Powerware® 9315 Parallel Capacity/Redundant System  
Installation and Operation (Powerware Hot Sync™ – Capacity)**

The manual contains the following information: how to prepare the site and plan for installation, detailed step-by-step procedures for installing the System Bypass Module (SBM), and detailed illustrations of cabinets and optional accessories, including dimensions and connection points.

This manual describes the SBM Control Panel, and explains the functions of the Parallel Capacity/Redundant System; discusses the standard features of the Parallel Capacity/Redundant System and optional accessories; provides procedures for starting and stopping the Parallel Capacity/Redundant System, and information about maintenance and responding to system events.

Also described are the RS–485 and RS–232 serial communications capabilities of the Parallel Capacity/Redundant System; the two communications ports on the Customer Interface Panel inside the SBM and how to connect optional remote accessories to your Parallel Capacity/Redundant System; and provide information about enabling, disabling, and customizing building alarms.

Contact the local Powerware Field Service office for information on how to obtain copies of these manuals.

## Getting Help

---

If you have a question about any of the information in this manual, or if you have a question this manual does not answer, please call Powerware Corporation Field Service:

**United States**

**1-800-843-9433**

**Canada**

**1-800-461-9166**

**Outside the U.S.**

**Call your local representative**



**This Page Intentionally Left Blank.**

# 1

## Getting Started

This section describes the Powerware Fixed Master Sync Control. It contains instructions for inspecting the unit and basic site preparation procedures.

The Powerware Fixed Master Sync Control is shipped as a separate item. It weighs approximately 80 lbs and can be mounted on any surface that can safely bear its weight. See Appendix A for complete dimensions and wiring interconnection data.

### Preparing the Site

---

For the Powerware Fixed Master Sync Control to operate at peak efficiency, the installation site should meet the environmental parameters outlined in the *Powerware 9315 Operation* manual provided with the single module Powerware 9315 UPS system or the *Installation and Operation* manual provided with the Powerware Hot Sync–Capacity system. The operating environment must accommodate the size and weight requirements supplied in the *Powerware 9315 Installation* manual provided with the single module Powerware 9315 UPS system or the *Powerware 9315 Installation and Operation* manual provided with the Powerware Hot Sync–Capacity system.

The basic environmental requirements for operation of the Powerware Fixed Master Sync Control are:

<b>Ambient Temperature Range:</b>	0–40° C (32–104° F)
<b>Recommended Operating Range:</b>	20–25° C (68–77° F)
<b>Maximum Relative Humidity:</b>	95% noncondensing

The Powerware Fixed Master Sync Control uses convection cooling to regulate internal component temperature.

### Creating an Installation Plan

---

Before beginning to install the Powerware Fixed Master Sync Control, read and understand how this manual applies to the system being installed. It is important to note that UPS module installation procedures are contained in the *Powerware 9315 Installation* and/or *Powerware 9315 Installation/Operation* manual provided with the single module Powerware 9315 UPS system and the System Bypass Module (SBM) installation procedures are contained in the *Powerware 9315 Installation and Operation* manual provided with the Powerware Hot Sync–Capacity system. It is recommended to first understand how to install the UPS modules or the SBM. The information in Chapter 2 of this manual is a guide for installation of the Powerware Fixed Master Sync Control to the UPS modules or SBM.

**NOTE:** *Installation of the Powerware Fixed Master Sync Control may require making interconnections to equipment that is not a Powerware product. Refer to the Installation manual provided with the OEM equipment.*

## Environmental Considerations

---

See the *Powerware 9315 Installation* manual provided with the Powerware 9315 UPS or Powerware Hot Sync–Capacity system.

## Preparing for Wiring the Powerware Fixed Master Sync Control

---

See Tables 1, 2, and 3 in Appendix A of this manual for wiring requirements. The wiring for this equipment is rated at 90°C. If wire is run in an ambient temperature greater than 30°C, higher temperature rating and/or larger size wire may be necessary. For UPS external wiring requirements, including minimum AWG size of external wiring, see the *Powerware 9315 Installation* manual provided with the single module Powerware 9315 UPS system or the Powerware Hot Sync–Capacity system.

**NOTE:** *Material and labor for external wiring are to be provided by designated personnel.*

## Inspecting and Unpacking the Powerware Fixed Master Sync Control

---

The first task in preparing for installation of the Powerware Fixed Master Sync Control is inspecting and unpacking the unit. The unit arrives covered with protective packaging material.

1. Carefully inspect the outer packaging for evidence of damage during transit.

### CAUTION



**Do not install a damaged Powerware Fixed Master Sync Control. Report any damage to the carrier and contact the local sales or service office immediately.**

---

2. Remove the protective cardboard covering from the Powerware Fixed Master Sync Control, by cutting where indicated using a knife blade no longer than 25 mm (1 in.).
3. Remove the plastic bag and foam packing material. Please discard or recycle them in a responsible manner.

# 2

## Installing the Powerware Fixed Master Sync Control

The Fixed Master Sync Control can be installed in your facility up to a maximum of 500 feet from the single module Powerware 9315 UPS or Powerware Hot Sync–Capacity system. When the Fixed Master Sync Control has been moved to its installed location, unpacked, and inspected, it is ready for installation. This section discusses typical installation of the Powerware Fixed Master Sync Control. Refer to the following while installing the Powerware Fixed Master Sync Control:

- Figure 164201325–1 of Appendix A of this manual for mounting hole dimensions, conduit entrance locations, and equipment grounding terminal location.
- Detailed control wiring information is provided in Tables 1, 2, and 3 of Appendix A of this manual.
- OEM Installation manual for interconnection to master source (provided by others)

Install the Powerware Fixed Master Sync Control panel to the selected mounting location.

**NOTE:** *The Fixed Master Sync Control requires that both the Powerware (Slave) system and the Master System voltage and frequency be the same. Verify the voltage and frequency of both systems with the nameplate rating of the Fixed Master Sync Control.*

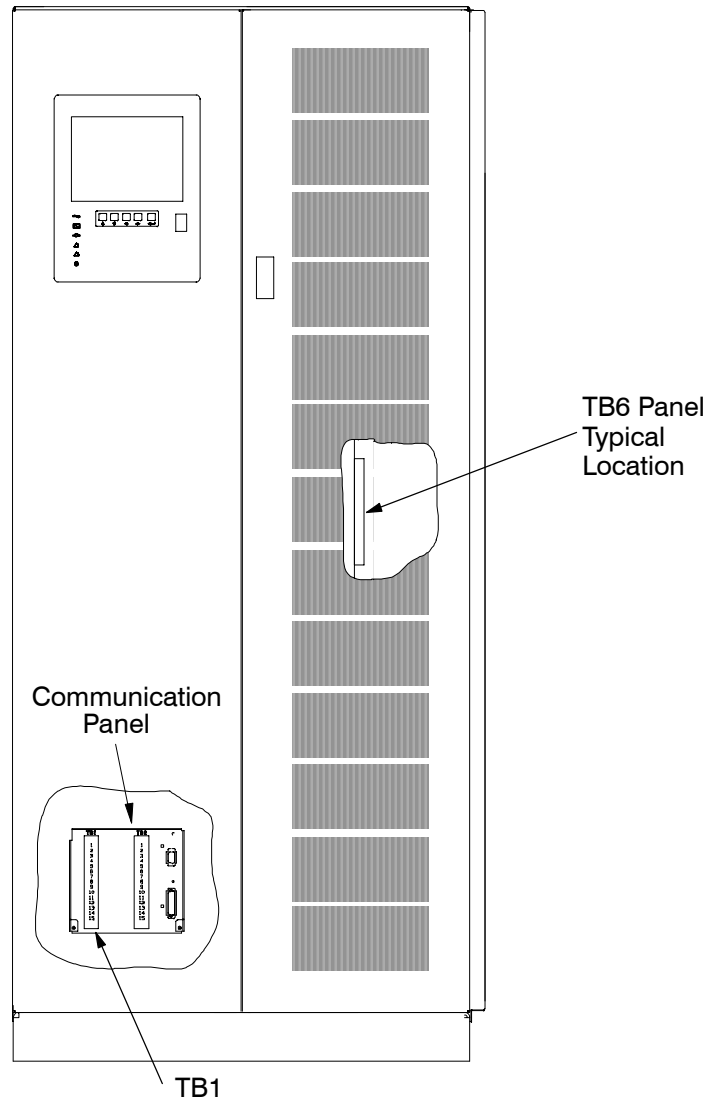
Complete all control wiring interconnections using Tables 1, 2, and 3 of Appendix A for wiring requirements. Figures 2 through 5 show the typical location of the TB1 and TB6 interconnect terminal blocks, within a single module Powerware 9315 UPS. Figure 6 shows customer TB2 connections for 750kVA unit. Figures 7 and 8 show the typical location of the System Bypass Module (SBM) Customer Interface Panel for the Powerware Hot Sync–Capacity. Figure 9 shows the TB3, TB4, TB6 and TB7 interconnect terminal blocks located on the SBM Customer Interface Panel. Figure 10 shows typical control wiring and power wiring terminations of the Powerware Fixed Master Sync Control. Also, refer to the Powerware 9315 UPS Installation manual provided with the single module Powerware 9315 UPS system or the Powerware 9315 Parallel Capacity/Redundant System (Hot Sync–Capacity) Installation manual provided with the SBM for location of UPS module and SBM cabinet wiring terminations.

**NOTE:** *Material and labor for external wiring are to be provided by designated personnel.*

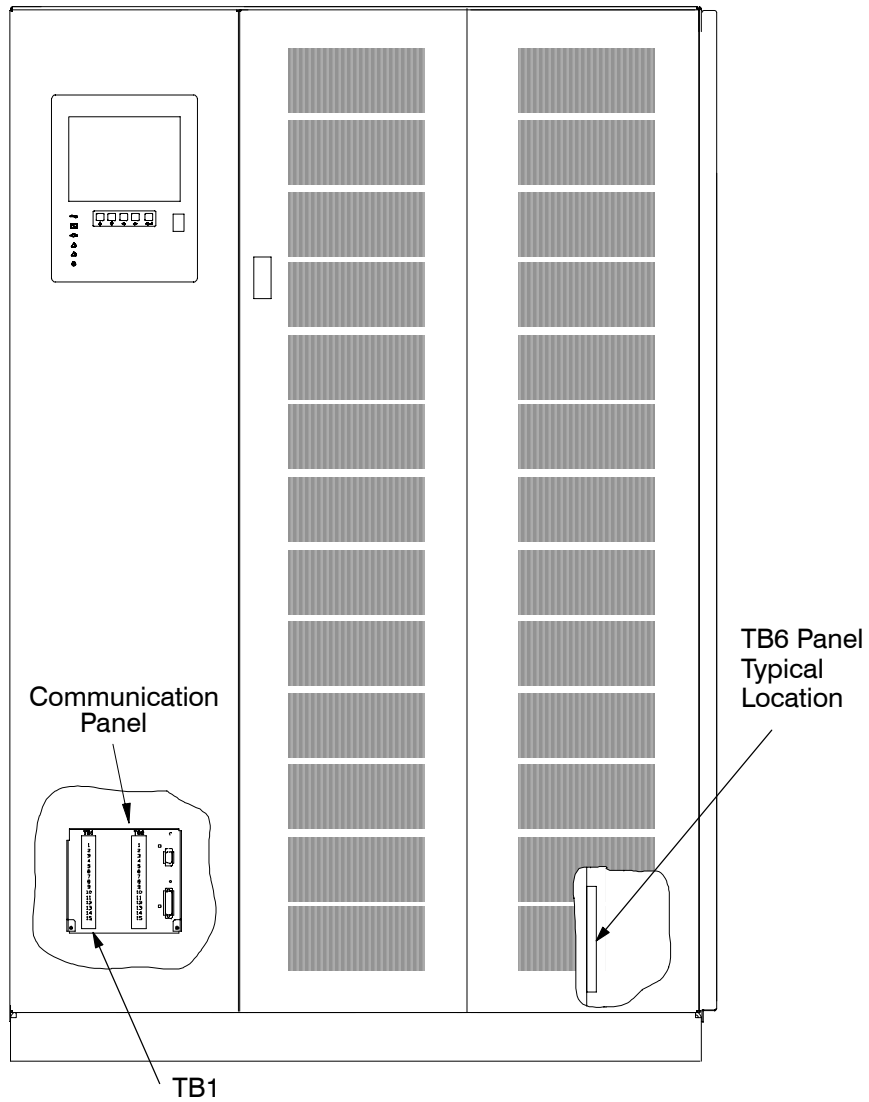
### WARNING



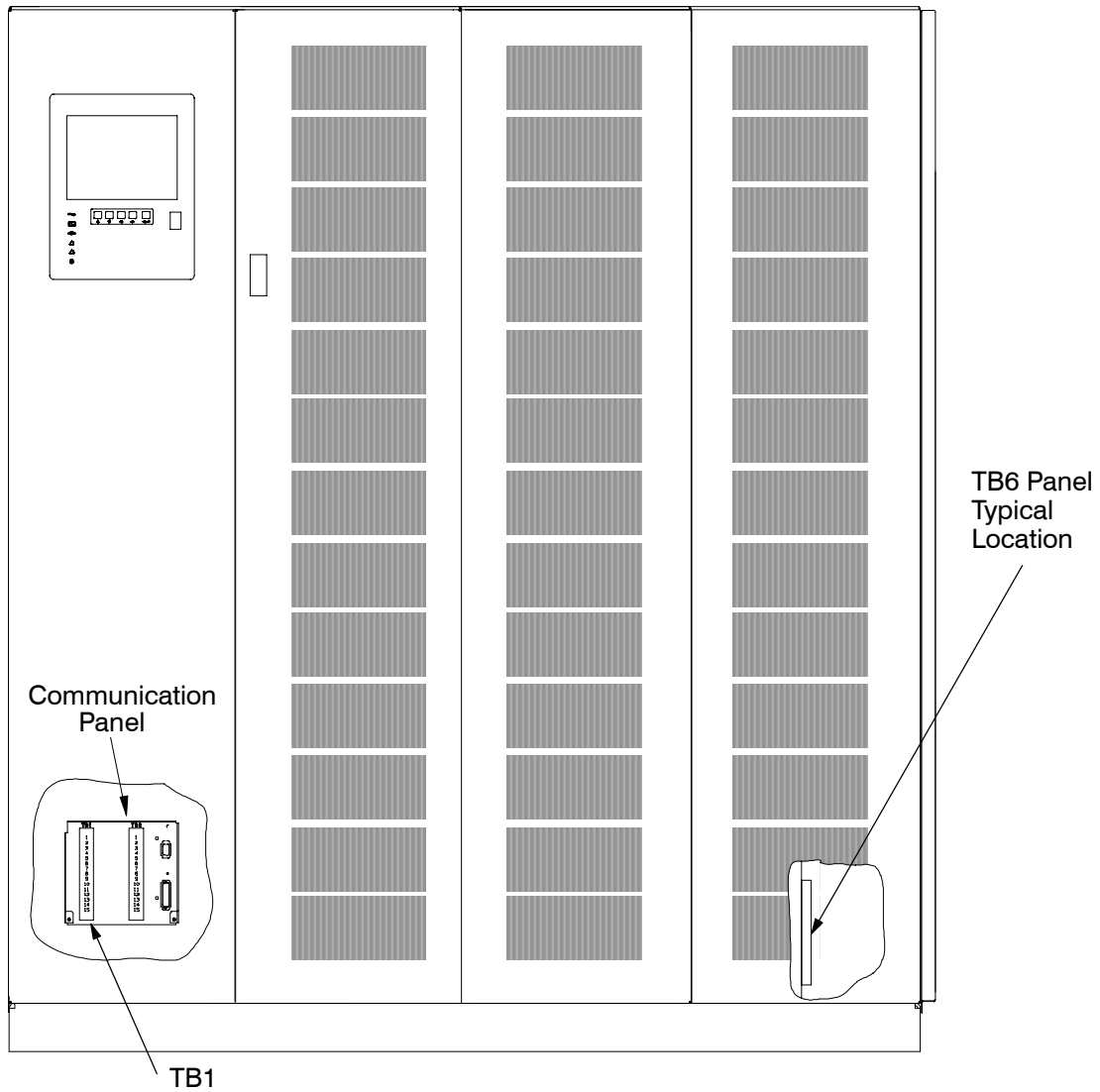
**Shut down all sources of power to the single module Powerware 9315 UPS or Powerware Hot Sync–Capacity system before connecting the control wiring to the Fixed Master Sync Control enclosure and UPS system or System Bypass Module (SBM). Hazardous voltages exist inside the UPS modules and in the Fixed Master Sync Control enclosure. Check all terminal conductors with a known serviceable voltmeter before connecting the wiring. Installation should only be performed by qualified personnel.**



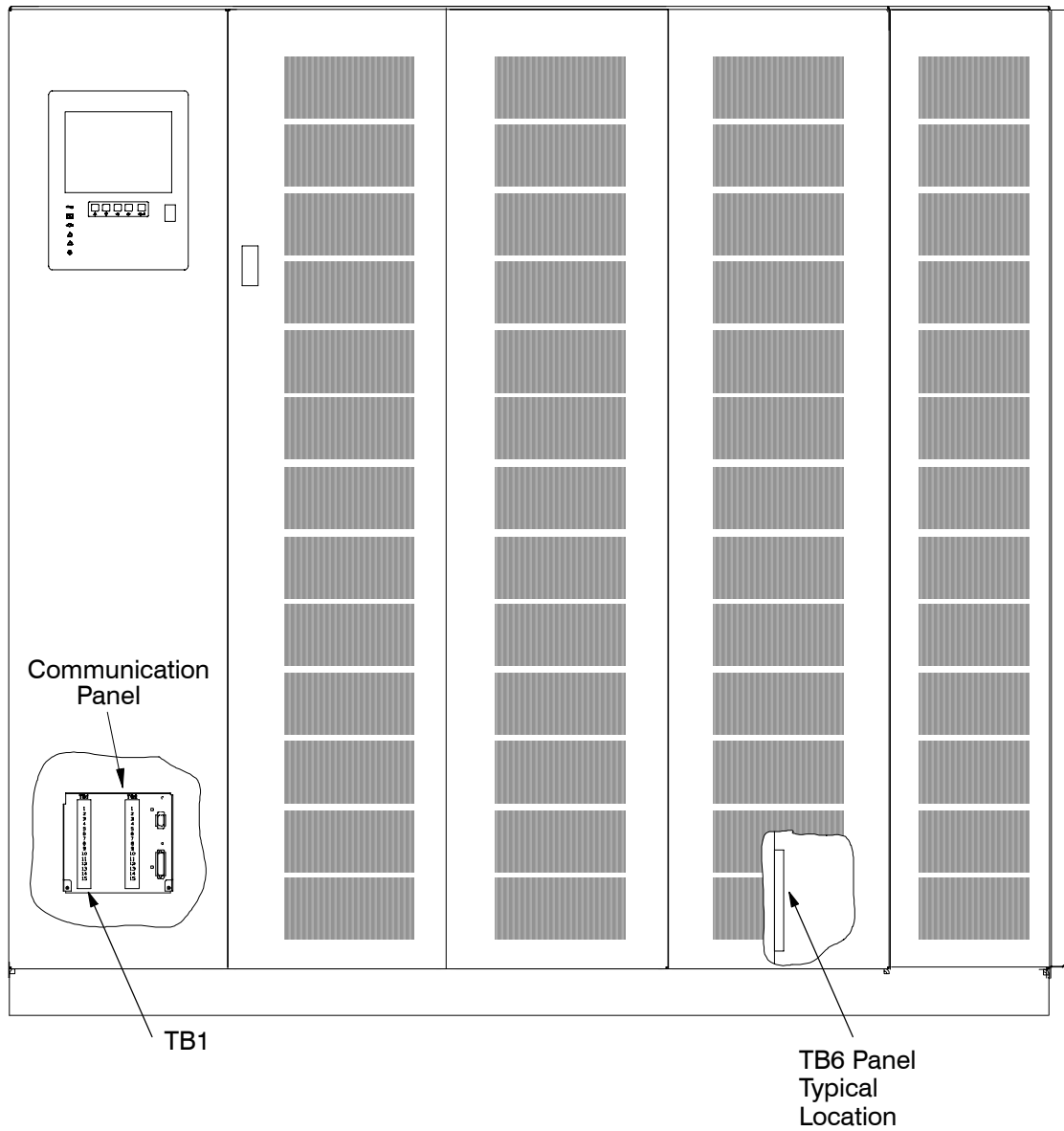
**Figure 2. Powerware Fixed Master Sync Control Interface Location for 30–80 kVA Single Module Powerware 9315 UPS System**



**Figure 3. Powerware Fixed Master Sync Control Interface Location for 100–160 kVA Single Module Powerware 9315 UPS System**

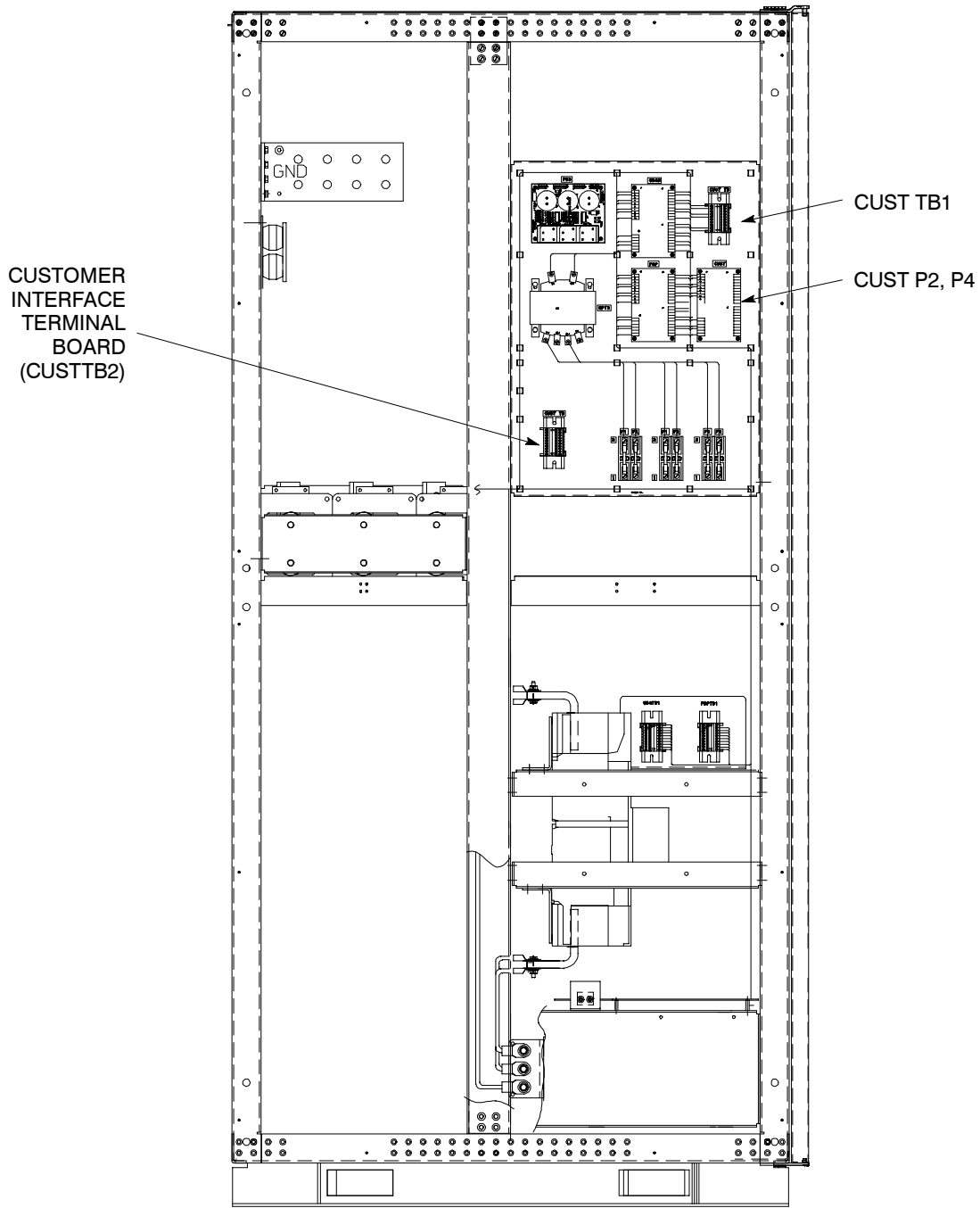


**Figure 4. Powerware Fixed Master Sync Control Interface Locations for 200–300 kVA Single Module Powerware 9315 UPS System**



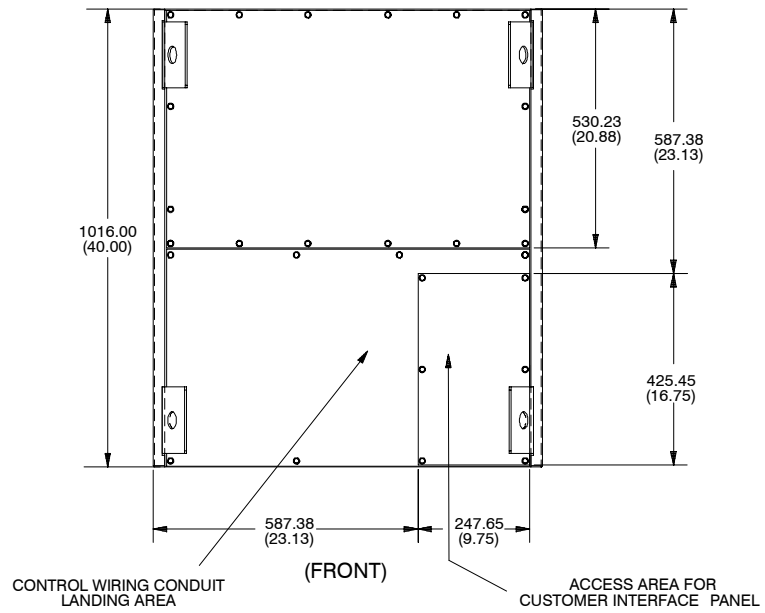
**Figure 5. Powerware Fixed Master Sync Control Interface Location for 400–500 kVA Single Module Powerware 9315 UPS System**



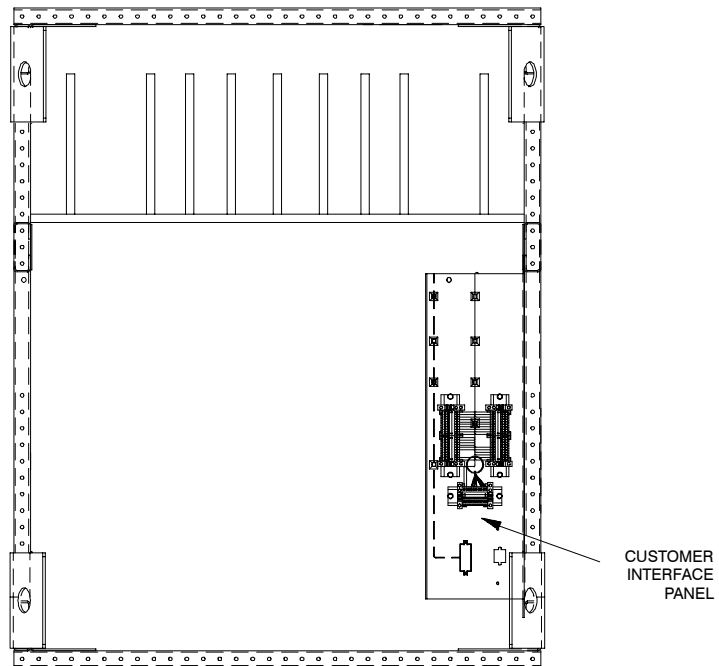


Left Side View, Reverse Transfer Cabinet (MBC)

**Figure 6. Powerware Fixed Master Sync Control Interface Location for 750 kVA Single Module Powerware 9315 UPS System**

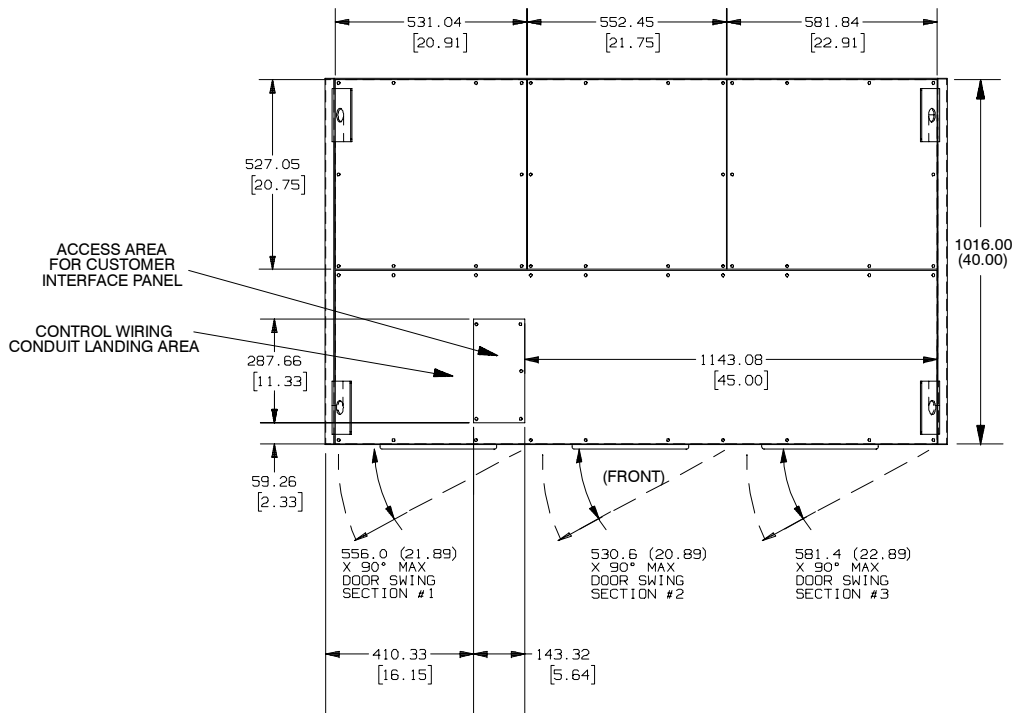


**TOP EXTERIOR VIEW**

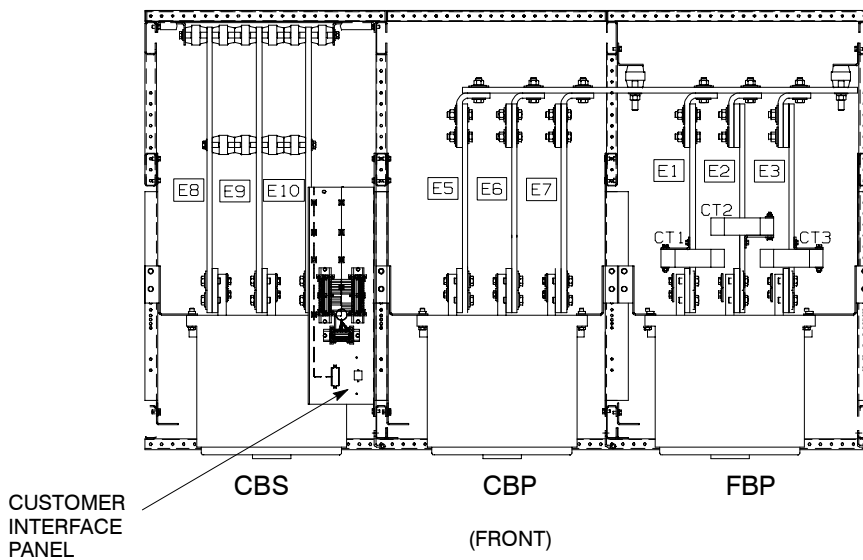


**TOP INTERIOR VIEW**

**Figure 7. Powerware Fixed Master Sync Control Interface Location for Powerware Hot Sync–Capacity System with 1200 Amp SBM**

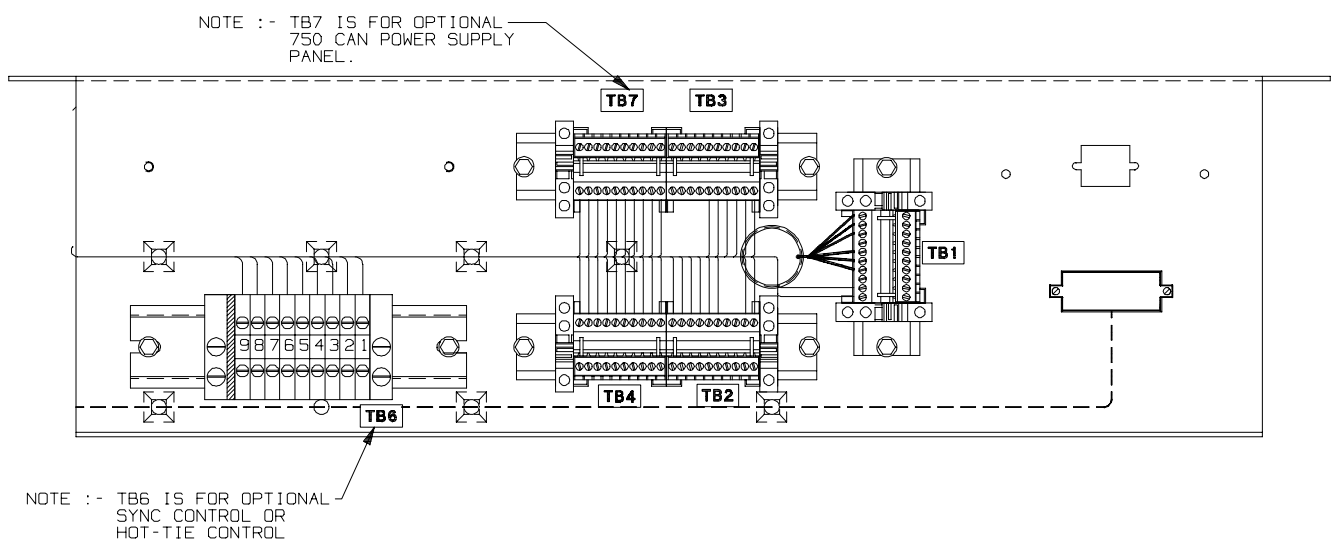


**TOP EXTERIOR VIEW**



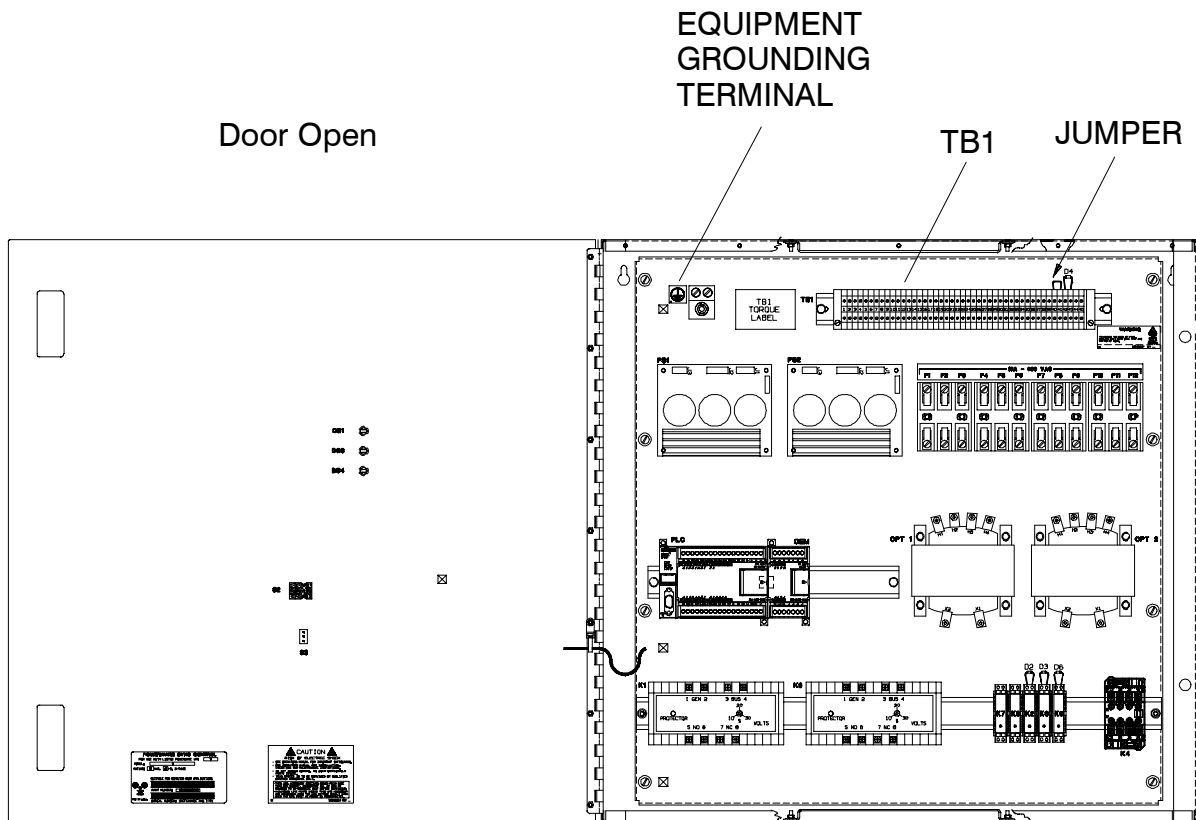
**TOP INTERIOR VIEW**

**Figure 8. Powerware Fixed Master Sync Control Interface Location for Powerware Hot Sync – Capacity System with 2000 Amp SBM**



## SBM and SSBM Customer Interface Panel Top View

**Figure 9. Location of (S)SBM Customer Interface Panel Terminal Blocks  
TB3, TB4, TB6 and TB7**



**Figure 10. Typical Control Wiring Termination Locations for the Powerware Fixed Master Sync Control**

# 3

## *Powerware Fixed Master Sync Control Operation*

This chapter describes the operation of the Powerware Fixed Master Sync Control with a UPS or SBM system.

### **Preliminary Checks and Startup for SBM Systems Equipped with a Powerware Fixed Master Sync Control**

Installation inspection and startup procedures must be performed only by an authorized service person. The procedure is normally part of the sales contract for the SBM system.

#### **WARNING**



**Attempts to startup the SBM system yourself may damage equipment and/or your critical load. Such attempts may also invalidate your system warranty.**

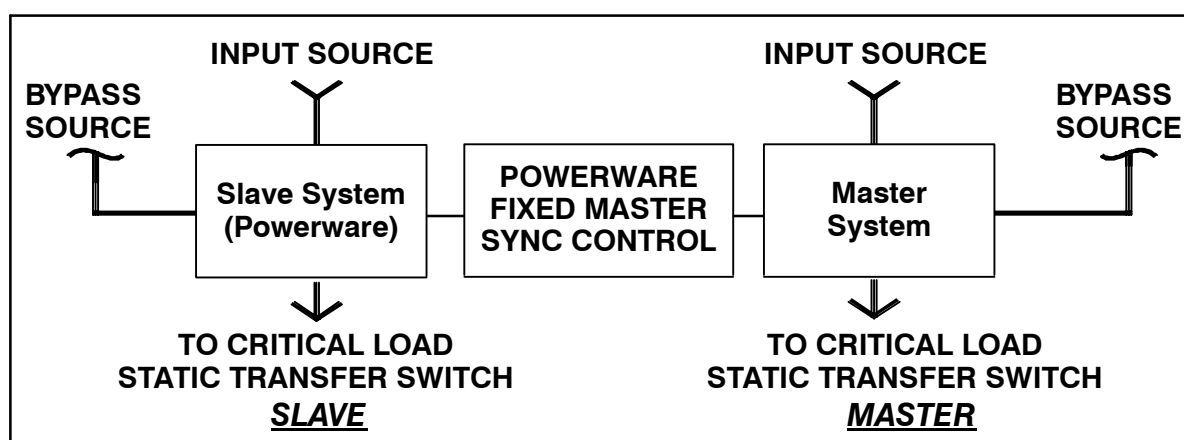
#### **CAUTION**



**As shipped, the Powerware Fixed Master Sync Control is setup for operation with a Powerware Hot Sync–Capacity system. For operation with a single-module Powerware 9315 UPS system, the jumper between terminal points TB1–40 and TB1–41 must be removed. Removal of this jumper must be performed by a Powerware authorized service person. Removal or installation of this jumper by anyone other than a Powerware authorized service person may damage the equipment and/or critical load and void the warranty.**

## Understanding Fixed Master Sync Control Operation

The Powerware Fixed Master Sync Control maintains critical load synchronization from an existing system (Master) to a single Powerware 9315 module system or to a Powerware Hot Sync-Capacity System (Slave). See Figure 11 for the block diagram of this system arrangement. This synchronization facilitates the uninterrupted transfer of customer loads from one load bus to another by means of downstream dual source solid state transfer switches. The automatic synchronization action of the Powerware Sync Control panel is enabled by pressing the LOAD SYNC ENABLE pushbutton switch on the front of the panel. When enabled, the LOAD SYNC ENABLE pushbutton lamp illuminates.



**Figure 11. Powerware Fixed Master Sync Control Block Diagram for a Powerware Hot Sync-Capacity System**

The Powerware Fixed Master Sync Control panel provides the synchronization reference to the Powerware System. The Slave system uses this reference to regulate the inverter phase relationship so that the system output maintains synchronization with the Master system. To establish the necessary synchronization reference, each system provides bypass and output (critical Load) bus voltage sensing to the Powerware Fixed Master Sync Control.

Under normal operating conditions, bypass sensing voltage from the slave system is provided back to its own inverter through the Powerware Fixed Master Sync Control. As long as the bypass sources feeding the slave system and the master system are available and in-phase with each other and the master critical load is in phase with its own bypass, the slave system remains synchronized with its own bypass source and the two systems remain synchronized with each other. If the slave system's bypass becomes out of phase with the master system bypass ( $>0.1$  Hz apart), the master critical load loses sync with its own bypass, or one or both sources become unavailable, the Powerware Fixed Master Sync Control provides a new synchronization reference to the slave system. The slave system's new reference is provided by the Powerware Fixed Master Sync Control from the output (critical load) bus of the Master system (See Figure 12).

When the two bypass sources regain availability and synchronization and the master critical load remains in sync with its bypass, the Powerware Fixed Master Sync Control provides the slave system with its own bypass sensing voltage as a synchronization reference. Before re-synchronization occurs, a fifteen second preset time delay has been provided to ensure the two bypass sources maintain acceptable synchronization.

In order to maintain a fault tolerant arrangement, fault conditions or abnormal operating conditions are accounted for in the Powerware Sync Control. The main provisions are listed below:

- 1.** When the Slave system is synchronized to the master source, a transfer to bypass disable signal is sent to the slave system. This inhibits any transfers to bypass on the slave system.
- 2.** If either of the systems or both loses its critical load bus voltage sensing, the slave system synchronizes to its own bypass source.
- 3.** Dual redundant logic power supplies are incorporated within the Powerware Fixed Master Sync Control, ensuring the slave system remains synchronized with the master even during the loss of one of the logic power supplies. If one or both power supplies fail, an alarm is sent back to the slave system indicating a "SYNC CONTROL TROUBLE" alarm. These power supplies are powered from each system's critical load bus.
- 4.** With a complete loss of logic power to the Powerware Fixed Master Sync Control (due to either component failure or power supply fault), the slave system synchronizes to its own bypass source.



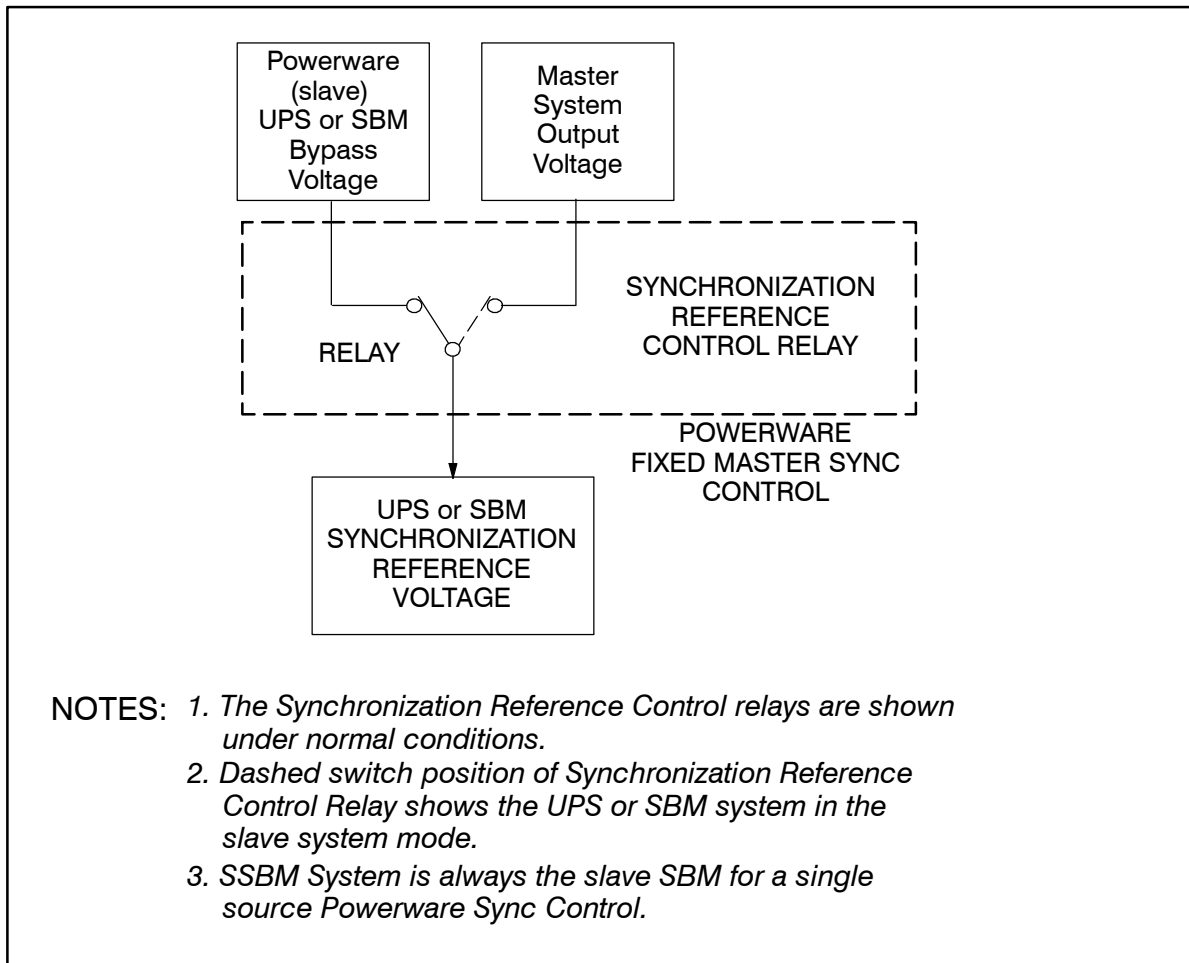
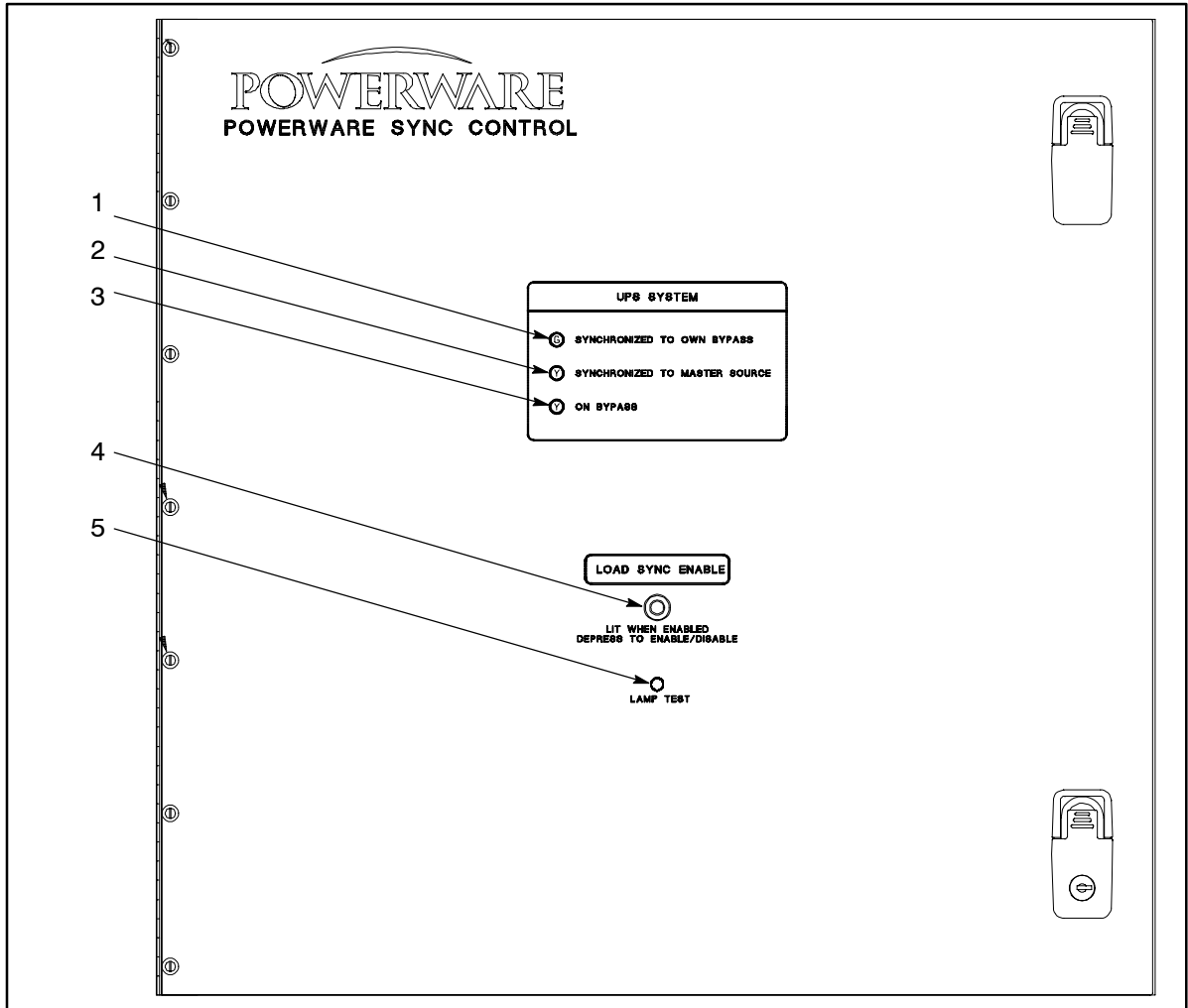


Figure 12. Synchronization Reference Control

## Operation

Perform the following procedures to set up the Powerware Fixed Master Sync Control for operation with your system. Refer to Figure 13 and Table 1 for the location and explanation of the controls and indicators on the Powerware Fixed Master Sync Control.

1. Place the slave system in normal operating mode in accordance with the procedures in the applicable operations manual supplied with the UPS system (refer to the *Introduction* in this manual for manual part numbers).
2. Depress the **LAMP TEST** pushbutton switch to verify all indicators illuminate and are working correctly.
3. Depress the **LOAD SYNC ENABLE** pushbutton switch to enable the automatic synchronization control. The pushbutton illuminates when the synchronization control is activated.
4. To disable the automatic synchronization control, depress the **LOAD SYNC ENABLE** pushbutton switch and verify the **LOAD SYNC ENABLE** pushbutton is extinguished.



**Figure 13. Powerware Fixed Master Sync Control Controls and Indicators**

Table 1. Controls and Indicators		
Item	Name	Function and Description
1	SYNCHRONIZED TO OWN BYPASS	When illuminated, indicates that the slave is synchronized to its own bypass.
2	SYNCHRONIZED TO MASTER SOURCE	When illuminated, indicates that the slave system is in the slave system mode and is synchronized to the master system load bus.
3	ON BYPASS	When illuminated, indicates that the slave system is on bypass. The SYNCHRONIZED TO OWN BYPASS light should also be illuminated.
4	LOAD SYNC ENABLE <i>LIT WHEN ENABLED DEPRESS TO ENABLE – DISABLE</i>	Enables or disables the automatic Powerware Fixed Master Sync Control unit. Switch is illuminated when load sync action is enabled.
5	LAMP TEST	Pushbutton illuminates all lamps on the Powerware Fixed Master Sync Control unit for visual testing.

## Customer Monitoring

---

An alarm for Sync Control Trouble from the Powerware Fixed Master Sync Control is provided to the single Powerware 9315 module system or Powerware Hot Sync-Capacity System as Building Alarm number 4. The alarm is activated for the following conditions:

- Failure of one or both power supplies
- PLC Mode switch in STOP position
- PLC shutdown due to fatal program error.

If the Sync Control Trouble alarm activates, contact Customer Service.

**NOTE:** *If either slave system or master system is taken out of service for maintenance, voltage input to one of the power supplies is lost, and the Sync Control Trouble alarm activates. The alarm clears when the UPS or SBM system is placed back into service. Customer Service need not be contacted.*

# Maintenance Operations

---

## CAUTION

Refer to the applicable manual before beginning maintenance or repairs on the UPS or SBM equipment:



- Chapter 9 – *Maintaining the UPS System* of the Powerware 9315 30–160kVA Operation manual, Powerware Corporation part number 164200252
- Chapter 9 – *Maintaining the UPS System* of the Powerware 9315 200–300kVA Operation manual, Powerware Corporation part number 164201036
- Chapter 9 – *Maintaining the UPS System* of the Powerware 9315 200–300kVA Operation manual, Powerware Corporation part number 164201119
- Chapter 15 – *Maintaining the Parallel Capacity/Redundant System* of the Powerware 9315 Parallel Capacity/Redundant System Installation and Operation manual, Powerware Corporation part number 164201150
- Chapter 17 – *Maintaining the UPS System* of the Powerware 9315 500–750kVA Installation and Operation manual, Powerware Corporation part number 164201244

Maintenance should be scheduled on a periodic basis, recommended not to exceed one year. More frequent intervals are recommended if the equipment is subjected to highly repetitive operations.

## WARNING



**Dangerous and life-threatening voltages are present when the UPS or SBM is operating. De-energize all equipment before physically touching potentially live parts.**

Periodic inspections of the Powerware Fixed Master Sync Control should be made to determine if components, wiring, and connections exhibit evidence of overheating or damage.

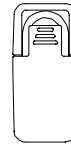
**This Page Intentionally Left Blank.**

## *Appendix A – Customer Information*

The information in this appendix will help you plan for and install your Powerware System Fixed Master Load Sync Control. This appendix contains the following drawings:

- 164201325–1 Fixed Master Sync Control
- 164201325–2 Powerware Sync Control Interface Location For Single Module Powerware 9315 UPS System
- 164201325–3 Powerware Sync Control Interface Location for Powerware Hot Sync–Capacity System with 1200 Amp SBM
- 164201325–4 Powerware Sync Control Interface Location for Powerware Hot Sync–Capacity System with 2000 Amp SBM
- 164201325–5 SBM & SSBM Customer Interface Panel
- 164201325–6 Oneline Drawing of Typical Powerware Hot Sync–Capacity System
- 164201325–7 Oneline Drawing Of Typical Single Module Powerware 9315 UPS System
- 164201325–8 Installation Notes
- 164201325–9 Table 1 – Single Module Powerware 9315 UPS System Control Wiring Interconnections (Slave)
- 164201325–10 Table 2 – Powerware Hot Sync-Capacity UPS System Control Wiring Interconnections (Slave)
- 164201325–11 Table 3 – Powerware System Control Wiring Interconnections (Master)
- 164201325–12 Simplified Powerware Fixed Master Sync Control Block Diagram

**POWERWARE**  
**POWERWARE SYNC CONTROL**



UPS SYSTEM	
Ⓞ	SYNCHRONIZED TO OWN BYPASS
Ⓜ	SYNCHRONIZED TO MASTER SOURCE
Ⓢ	ON BYPASS

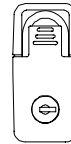
LOAD SYNC ENABLE



LIT WHEN ENABLED  
 DEPRESS TO ENABLE/DISABLE



LAMP TEST



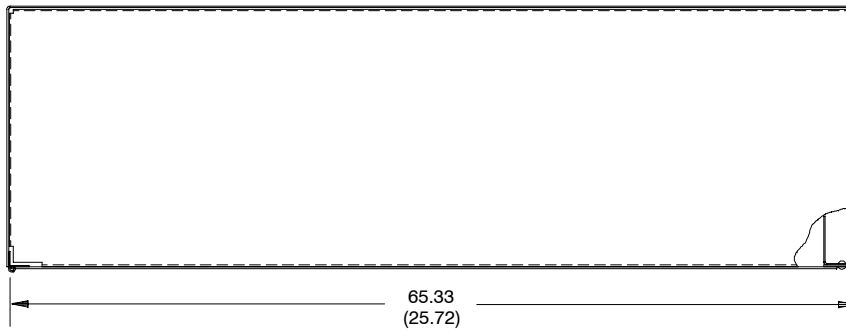
64.77  
 (25.5)

65.33  
 (25.72)

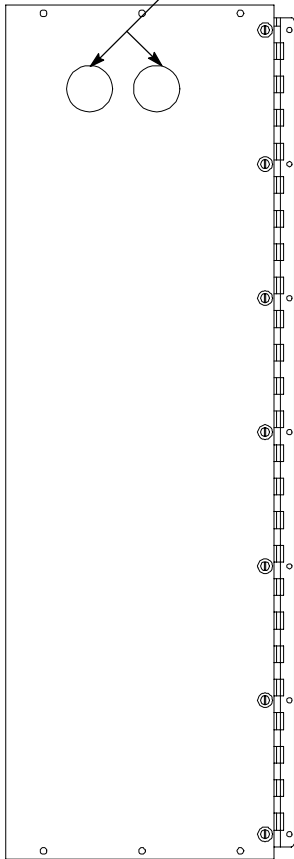
All dimensions are in centimeters (inches)

DESCRIPTION:	<b>FIXED MASTER SYNC CONTROL</b>	
DRAWING NO:	164201325-1	SHEET: 1 of 3

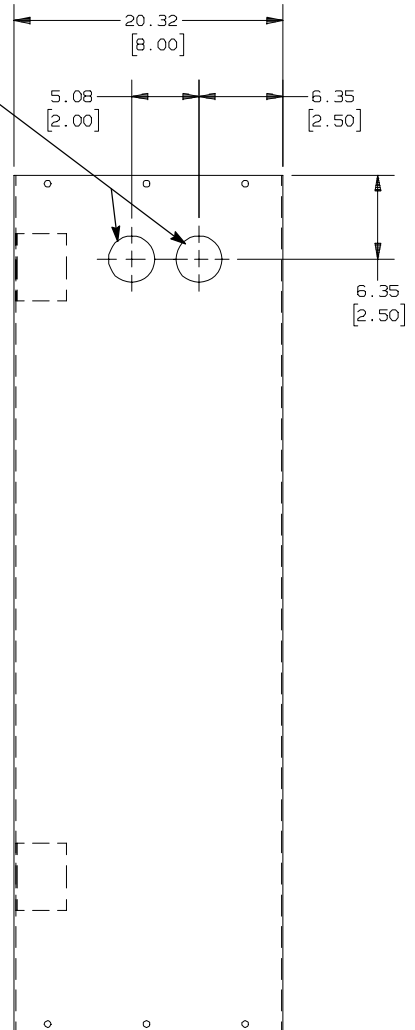
**TOP SIDE VIEW**



**KNOCKOUT  
HOLES FOR 1  
INCH CONDUIT**



**LEFT SIDE VIEW**



**RIGHT SIDE VIEW**

All dimensions are in centimeters (inches)

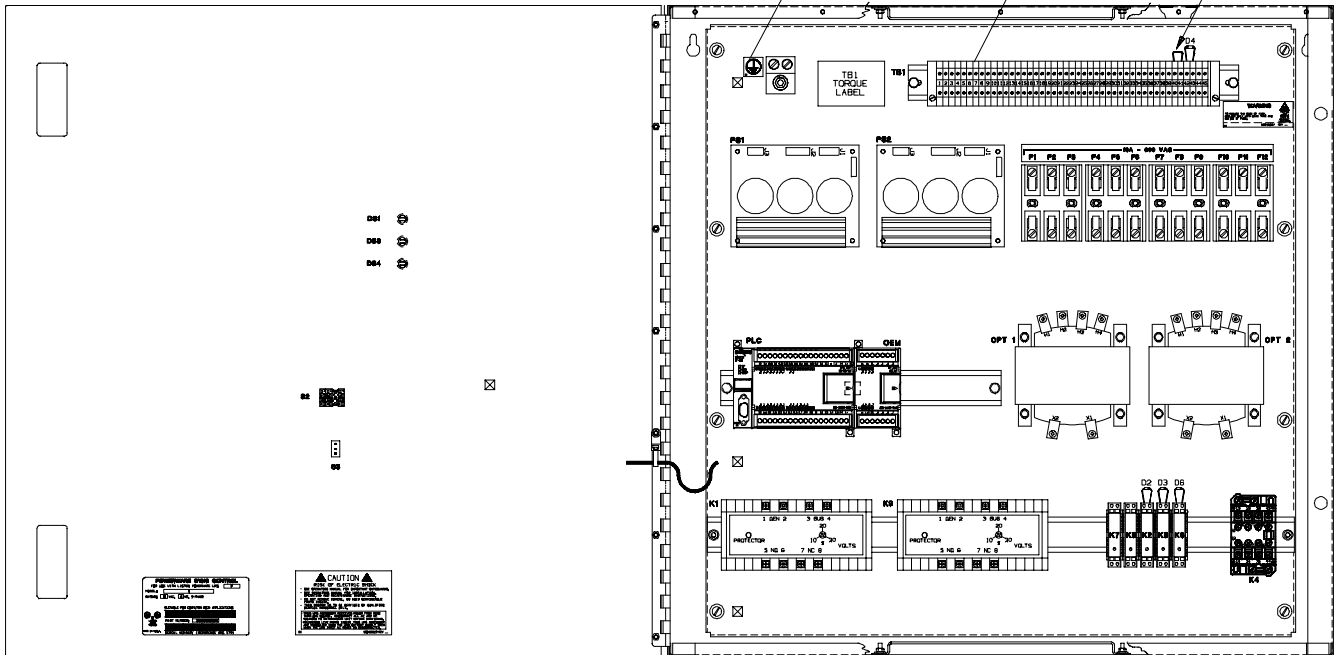
DESCRIPTION:	<b>FIXED MASTER SYNC CONTROL</b>	
DRAWING NO:	164201325-1	SHEET: 2 of 3



EQUIPMENT  
GROUNDING  
TERMINAL

TB1

JUMPER



## FIXED MASTER SYNC CONTROL ENCLOSURE

FRONT VIEW WITH DOOR OPEN

### CAUTION:

As shipped, the Powerware Sync Control is setup for operation with a Powerware Hot Sync–Capacity system. For operation with a single module Powerware 9315 UPS system, the jumper between terminal points TB1–40 and TB1–41 must be removed. Removal of this jumper must be performed by an authorized service person. Removal or installation of this jumper by anyone but an authorized service person may damage the equipment and/or critical load and void the warranty.

DESCRIPTION:

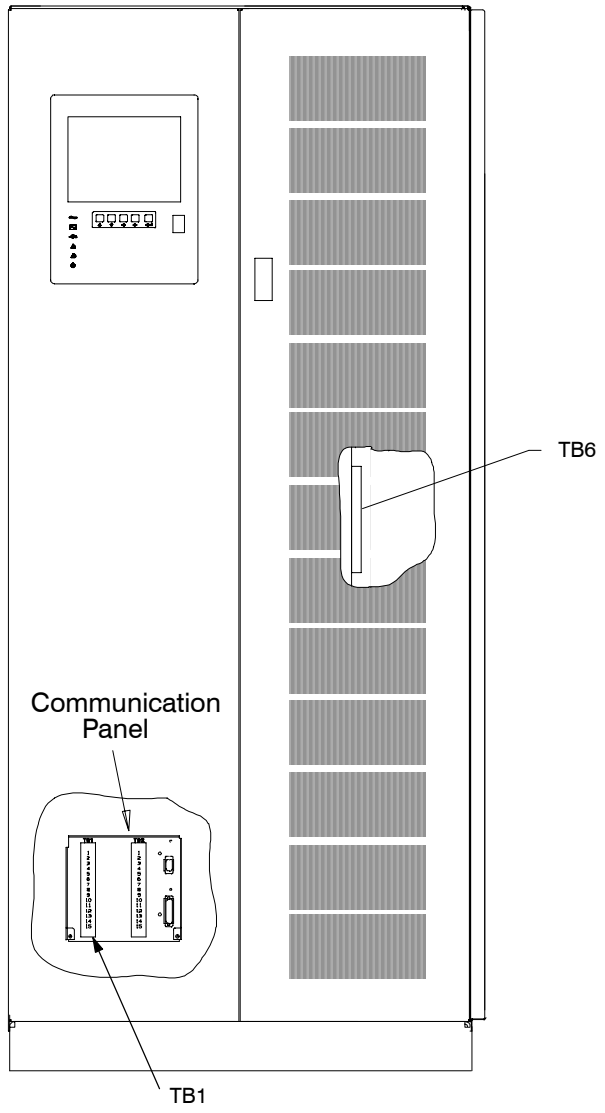
**FIXED MASTER SYNC CONTROL**

DRAWING NO:

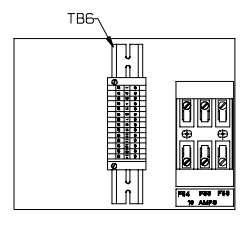
164201325–1

SHEET:

3 of 3

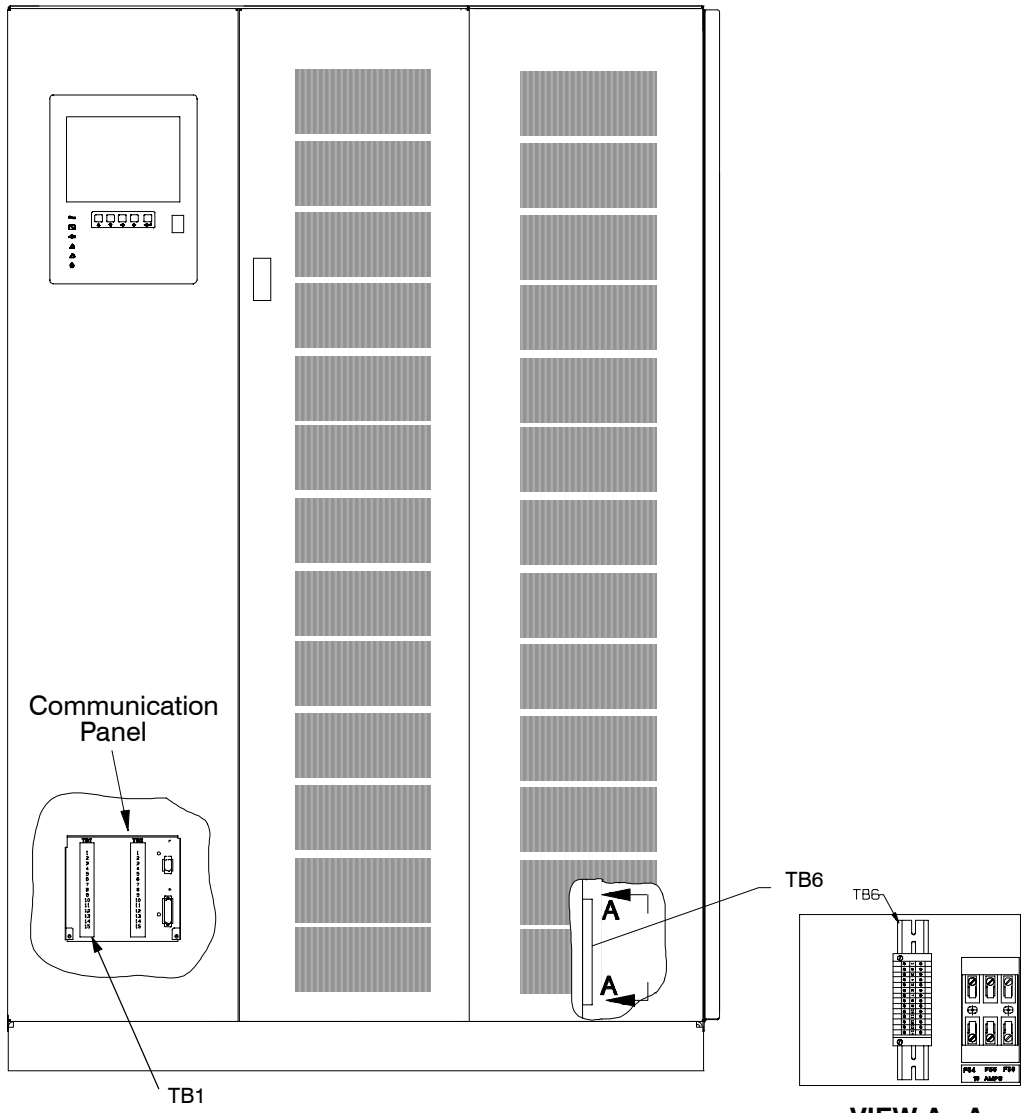


**POWERWARE 9315  
MODEL 30 – 80 KVA**



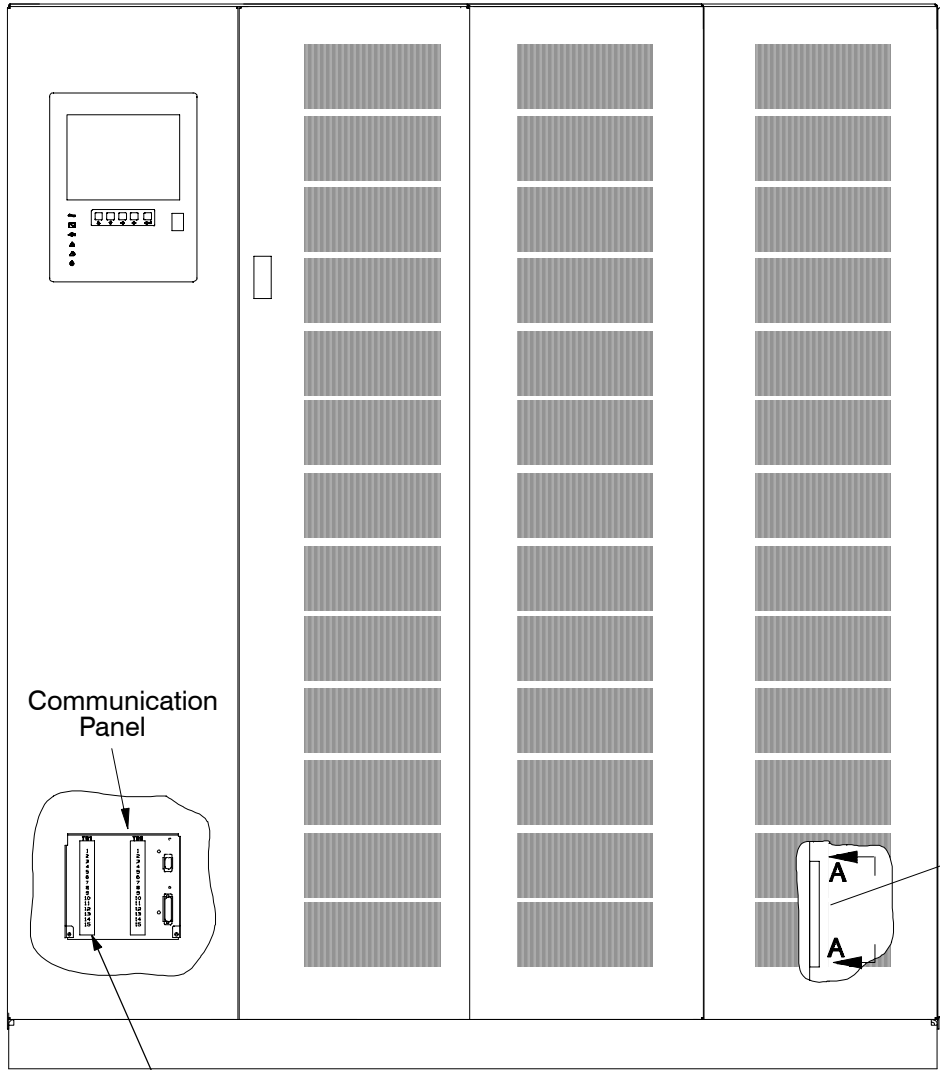
**VIEW A-A**

<i>DESCRIPTION:</i> <b>POWERWARE SYNC CONTROL INTERFACE LOCATION FOR SINGLE MODULE POWERWARE 9315 UPS SYSTEM</b>	
<i>DRAWING NO:</i> 164201325-2	<i>SHEET:</i> 1 of 5



**POWERWARE 9315  
MODEL 100 – 160 KVA**

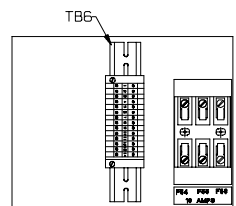
<b>DESCRIPTION: POWERWARE SYNC CONTROL INTERFACE LOCATION FOR SINGLE MODULE POWERWARE 9315 UPS SYSTEM</b>	
<b>DRAWING NO:</b> 164201325-2	<b>SHEET:</b> 2 of 5



Communication Panel

TB1

TB6



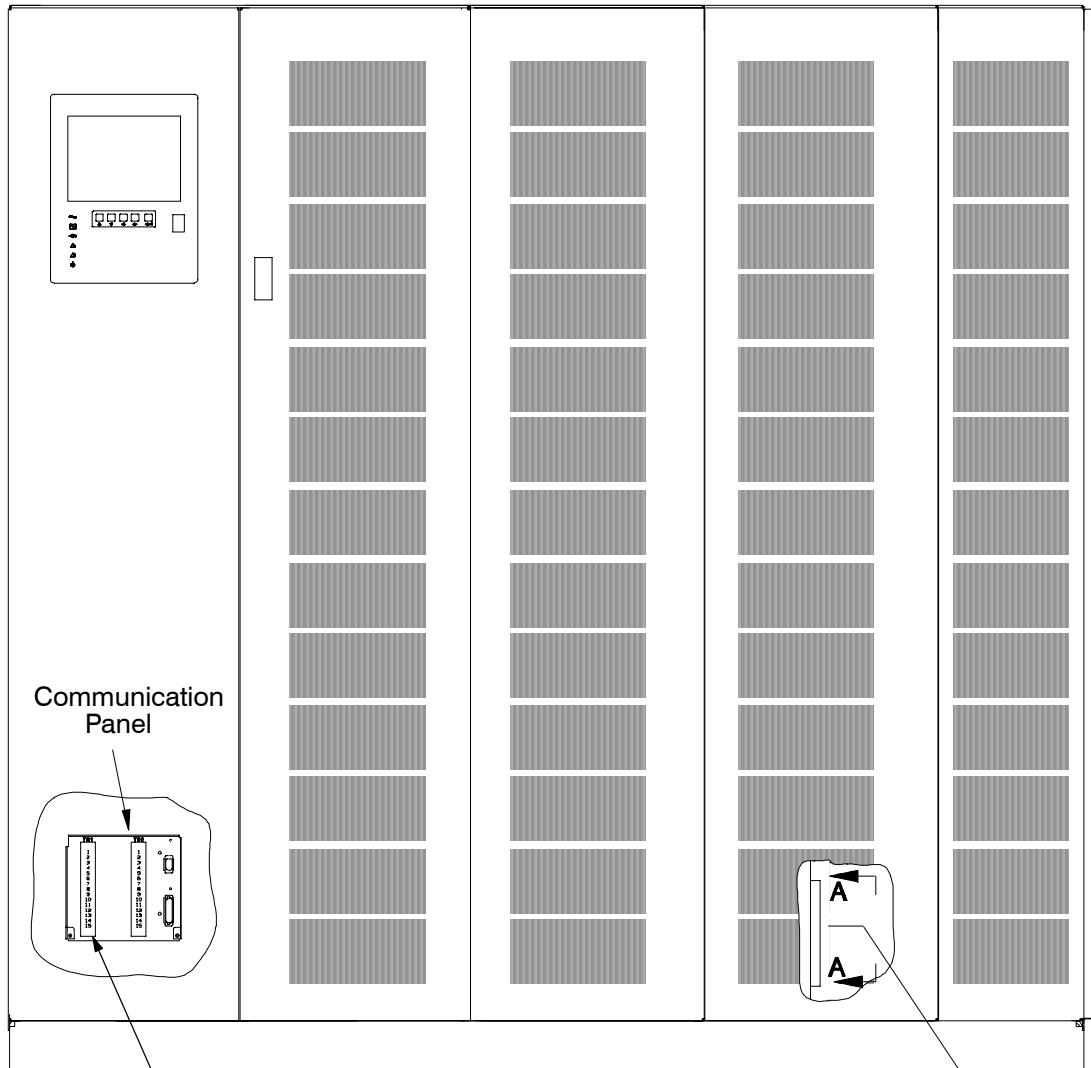
VIEW A-A

**POWERWARE 9315**  
**MODEL 200 – 300 KVA**

**DESCRIPTION: POWERWARE SYNC CONTROL INTERFACE  
 LOCATION FOR SINGLE MODULE  
 POWERWARE 9315 UPS SYSTEM**

**DRAWING NO:** 164201325-2

**SHEET:** 3 of 5

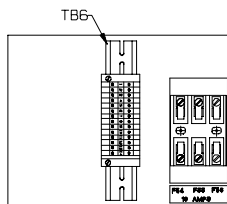


Communication Panel

TB1

TB6

**POWERWARE 9315  
MODEL 400 – 500 KVA**

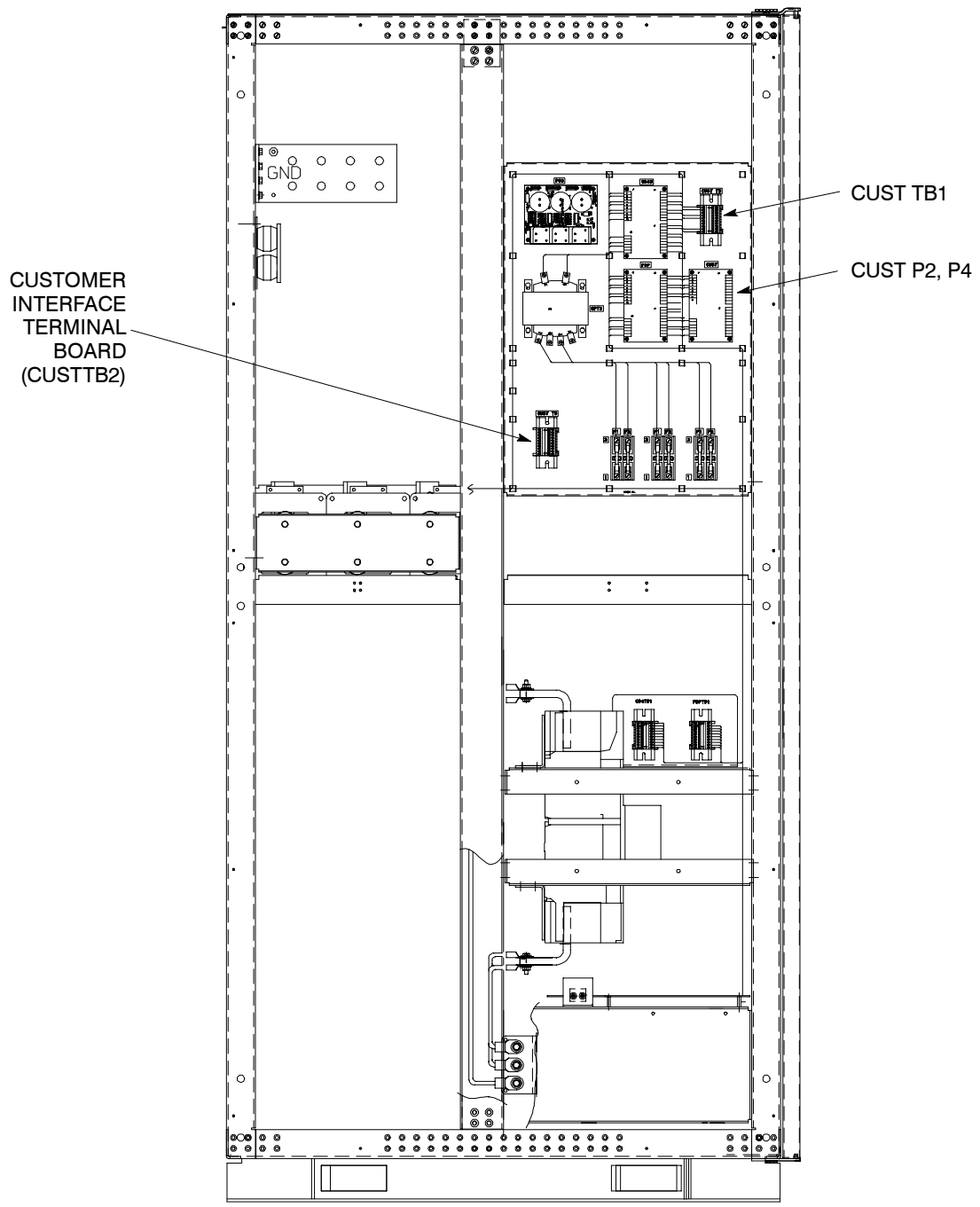


**VIEW A-A**

**DESCRIPTION: POWERWARE SYNC CONTROL INTERFACE  
LOCATION FOR SINGLE MODULE  
POWERWARE 9315 UPS SYSTEM**

DRAWING NO: 164201325-2

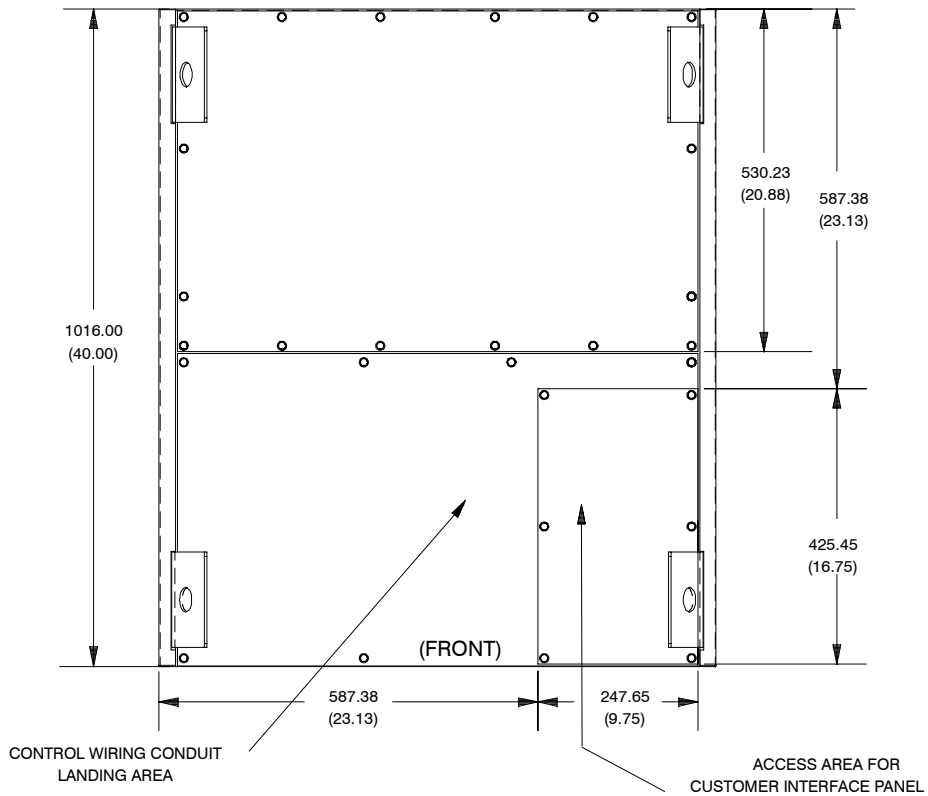
SHEET: 4 of 5



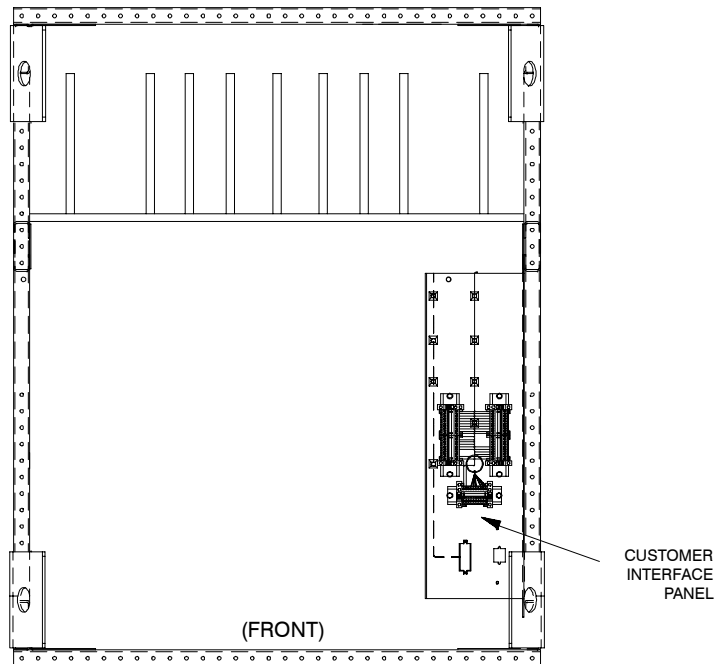
Left Side View, Reverse Transfer Cabinet (MBC)

**POWERWARE 9315**  
**MODEL 625-750 (625-750kVA)**

DESCRIPTION:		<b>POWERWARE SYNC CONTROL INTERFACE LOCATION FOR 750kVA UPS</b>
DRAWING NO:	164201325-2	SHEET: 5 of 5

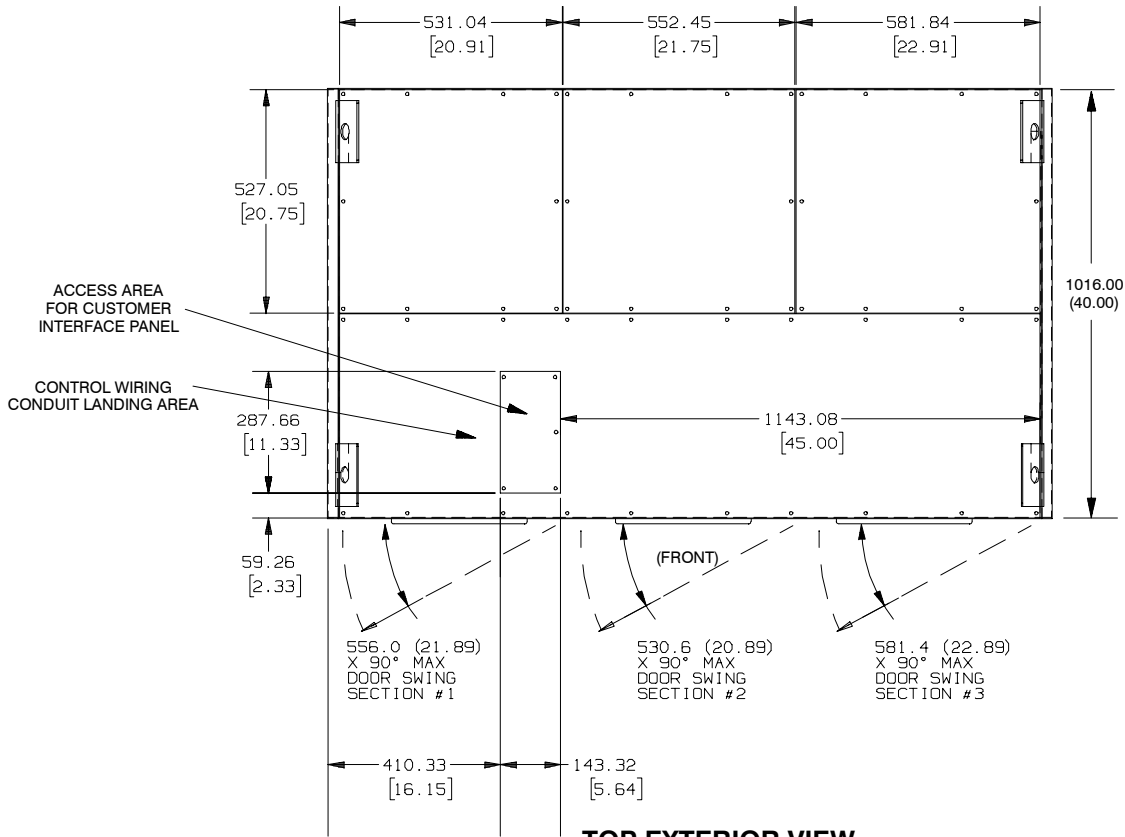


**TOP EXTERIOR VIEW**

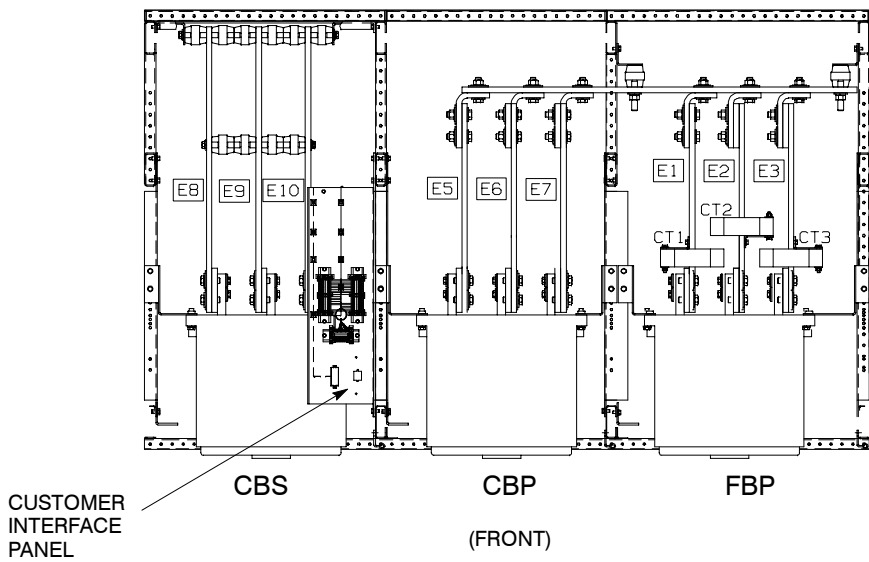


**TOP INTERIOR VIEW**

<b>DESCRIPTION: POWERWARE SYNC CONTROL INTERFACE LOCATION FOR POWERWARE HOT SYNC – CAPACITY SYSTEM WITH 1200 AMP SBM</b>		
<b>DRAWING NO:</b>	164201325-3	<b>SHEET:</b> 1 of 1



**TOP EXTERIOR VIEW**

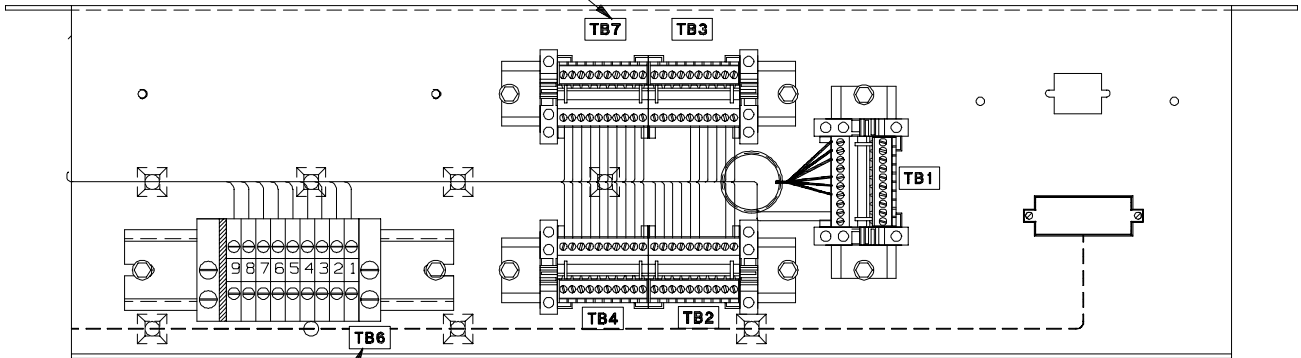


**TOP INTERIOR VIEW**

<i>DESCRIPTION:</i> <b>POWERWARE SYNC CONTROL INTERFACE LOCATION FOR POWERWARE HOT SYNC-CAPACITY SYSTEM WITH 2000 AMP SBM</b>		
<i>DRAWING NO:</i>	164201325-4	<i>SHEET:</i> 1 of 1



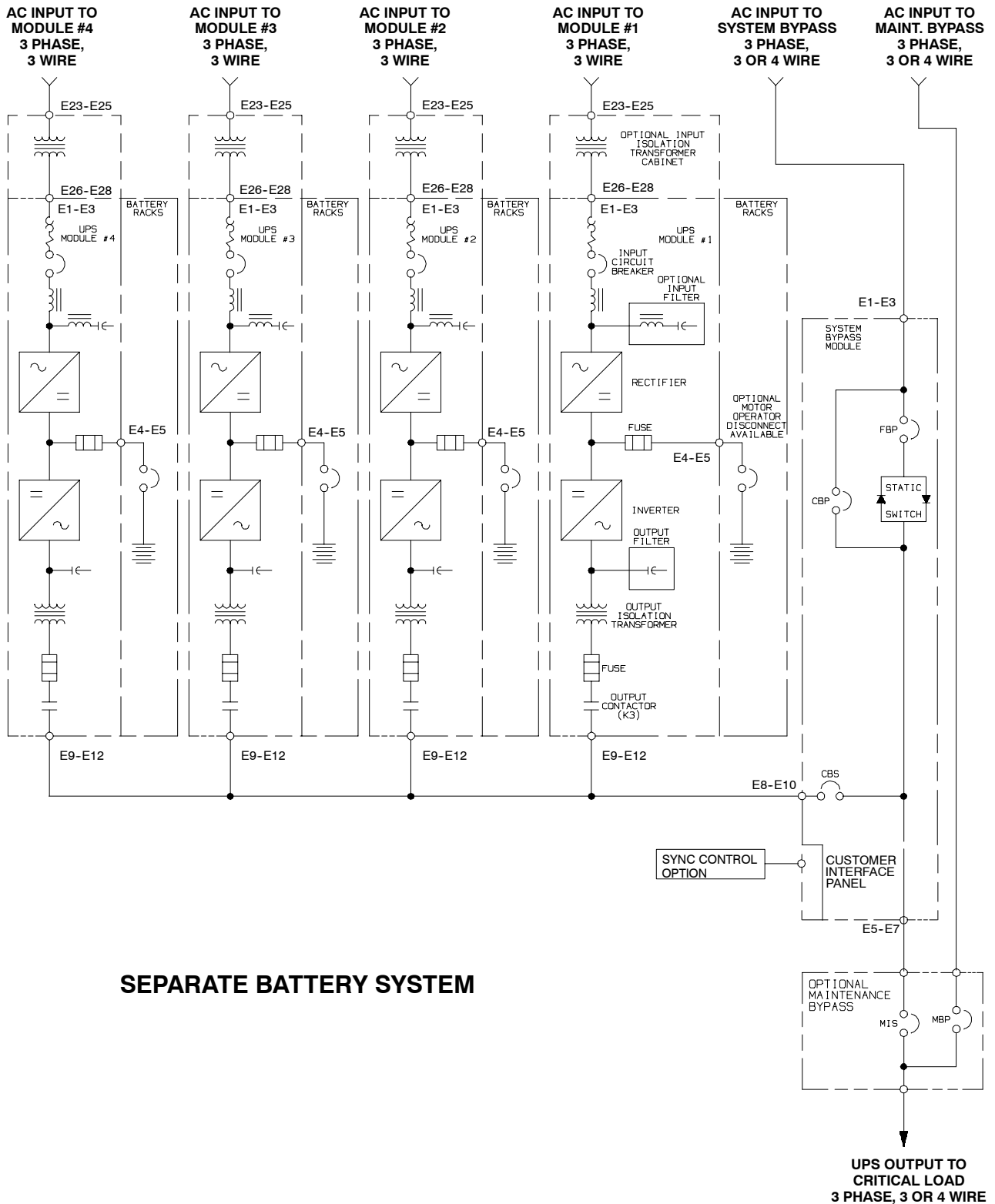
NOTE :- TB7 IS FOR OPTIONAL  
750 CAN POWER SUPPLY  
PANEL.



NOTE :- TB6 IS FOR OPTIONAL  
SYNC CONTROL OR  
HOT-TIE CONTROL

## SBM and SSBM CUSTOMER INTERFACE PANEL TOP VIEW

<b>DESCRIPTION:</b> <b>SBM &amp; SSBM CUSTOMER INTERFACE PANEL</b>	
<b>DRAWING NO:</b> 164201325-5	<b>SHEET:</b> 1 of 1



**SEPARATE BATTERY SYSTEM**

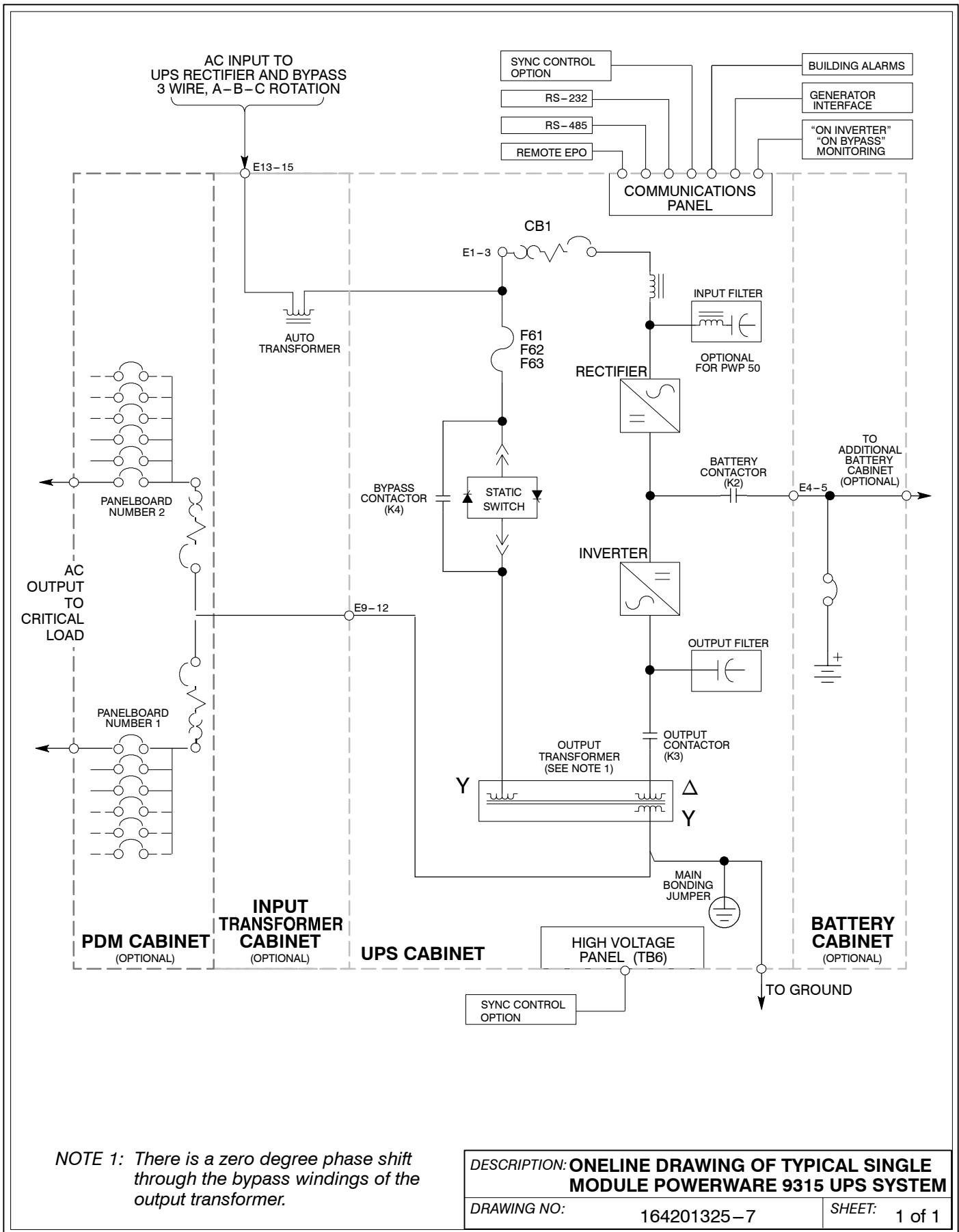
**DESCRIPTION: ONELINE DRAWING OF TYPICAL POWERWARE HOT SYNC-CAPACITY SYSTEM**

DRAWING NO:

164201325-6

SHEET:

1 of 1



**NOTE 1:** There is a zero degree phase shift through the bypass windings of the output transformer.

<b>DESCRIPTION: ONLINE DRAWING OF TYPICAL SINGLE MODULE POWERWARE 9315 UPS SYSTEM</b>		
<b>DRAWING NO:</b>	164201325-7	<b>SHEET:</b> 1 of 1

Read and understand the following notes while planning your installation:

1. Refer to national and local electrical codes for acceptable external wiring practices.
2. Material and labor for external wiring requirements are to be provided by others.
3. For external wiring requirements, including the minimum AWG size of external wiring, see the appropriate column in the following tables.

<i>DESCRIPTION:</i>	<b>INSTALLATION NOTES</b>	
<i>DRAWING NO:</i>	164201325-8	<i>SHEET:</i> 1 of 1

SINGLE MODULE 30-500 POWERWARE 9315 UPS SYSTEM CONTROL WIRING INTERCONNECTIONS			
From Slave UPS (refer to dwg 164201325-2)	To Sync Control (refer to dwg 164201325-1)	Description	Remarks
TB6-3	TB1-1	UPS ON BYPASS	Twist Together
TB6-4	TB1-2		
TB6-5	TB1-4	BYPASS VOLTAGE	Twist Together
TB6-6	TB1-5		
TB6-7	TB1-6		
TB6-11	TB1-13	LOAD VOLTAGE	Twist Together
TB6-12	TB1-14		
TB6-13	TB1-15		
TB6-8	TB1-16	REFERENCE VOLTS	Twist Together
TB6-9	TB1-17		
TB6-10	TB1-18		
TB1-9	TB1-22	BYPASS DISABLED	Twist Together
TB1-10	TB1-23		
TB1-7	TB1-26	PLC FAILURE ALARM	Twist Together
TB1-8	TB1-27		

** CAUTION**

Remove the following jumpers, if connected, from UPS module terminal block TB6 when installing the Sync Control:

<u>From</u>	<u>To</u>
TB6-5	TB6-8
TB6-6	TB6-9
TB6-7	TB6-10

Field Wiring Requirements:

- Minimum insulation rating: 600 volts
- Use 14 AWG wiring for interconnections between the Sync Control and the UPS modules.
- Install using Class 1 wiring methods.

<i>DESCRIPTION:</i> <b>Table 1 – Single Module Powerware 9315 UPS System Control Wiring Interconnections (Slave)</b>	
<i>DRAWING NO:</i> 164201325-9	<i>SHEET:</i> 1 of 2

SINGLE MODULE 750kVA POWERWARE 9315 UPS SYSTEM CONTROL WIRING INTERCONNECTIONS			
From Slave UPS (refer to dwg 164201325-2)	To Sync Control (refer to dwg 164201325-1)	Description	Remarks
CUSTTB1-1	TB1-1	UPS ON BYPASS (24VDC)	Twist Together
CUSTTB1-2	TB1-2		
CUSTTB2-1	TB1-4	BYPASS VOLTAGE (480VAC)	Twist Together
CUSTTB2-2	TB1-5		
CUSTTB2-5	TB1-13	LOAD VOLTAGE (480VAC)	Twist Together
CUSTTB2-6	TB1-14		
CUSTTB2-3	TB1-16	REFERENCE VOLTAGE (480VAC)	Twist Together
CUSTTB2-4	TB1-17		
CUSTTB-6*	TB1-22	BYPASS DISABLED (24VDC)	Twist Together
CUSTTB-7*	TB1-23		
CUSTP2-4	TB1-26	PLC FAILURE ALARM (24VDC)	Twist Together
CUSTT2-5	TB1-27		

\* CUST TB located in Inverter Cabinet #2

**⚠ CAUTION**

Remove the following jumpers, if connected, from UPS module terminal block TB6 when installing the Sync Control:

<u>From</u>	<u>To</u>
CUSTTB2-1	CUSTTB2-3
CUSTTB2-2	CUSTTB2-4

Field Wiring Requirements:

- Minimum insulation rating: 600 volts
- Use 14 AWG wiring for interconnections between the Sync Control and the UPS modules.
- Install using Class 1 wiring methods.

<i>DESCRIPTION:</i> <b>Table 1 – Single Module Powerware 9315 UPS System Control Wiring Interconnections (Slave)</b>	
<i>DRAWING NO:</i>	164201325-9
<i>SHEET:</i>	2 of 2

POWERWARE 9315 UPS HOT SYNC-CAPACITY SYSTEM CONTROL WIRING INTERCONNECTIONS			
From Slave SBM (refer to dwg 164201325-2)	To Sync Control (refer to dwg 164201325-1)	Description	Remarks
TB4-3	TB1-1	UPS ON BYPASS	Twist Together
TB4-4	TB1-2		
TB6-1	TB1-4	BYPASS VOLTAGE	Twist Together
TB6-2	TB1-5		
TB6-3	TB1-6	LOAD VOLTAGE	Twist Together
TB6-7	TB1-13		
TB6-8	TB1-14		
TB6-9	TB1-15	REFERENCE VOLTS	Twist Together
TB6-4	TB1-16		
TB6-5	TB1-17		
TB6-6	TB1-18	BYPASS DISABLED	Twist Together
TB3-3	TB1-22		
TB3-4	TB1-23	PLC FAILURE ALARM	Twist Together
TB3-1	TB1-26		
TB3-2	TB1-27		

Note: Sync Control dry contacts are rated at 5–30 VDC/250 VAC at 2A per contact (maximum load).

Field Wiring Requirements:

- Minimum insulation rating: 600 volts
- Use 14 AWG wiring for interconnections between the Sync Control and the UPS modules.
- Install using Class 1 wiring methods.

<i>DESCRIPTION:</i>		
<b>Table 2 – Powerware Hot Sync-Capacity UPS System Control Wiring Interconnections (Slave)</b>		
<i>DRAWING NO.:</i>	164201325–10	<i>SHEET:</i> 1 of 1

SINGLE MODULE 30-500 POWERWARE 9315 UPS SYSTEM CONTROL WIRING INTERCONNECTIONS			
From UPS System (Master)	To Sync Control	Description	Remarks
TB6-5	TB1-10	BYPASS REFERENCE VOLTAGE	Twist Together
TB6-6	TB1-11		
TB6-11	TB1-7	SYNC VOLTAGE	Twist Together
TB6-12	TB1-8		
TB6-13	TB1-9		

Install the following jumpers, if not connected, on UPS module terminal block TB6 when installing the Fixed Master Sync Control:

<u>From</u>	<u>To</u>
TB6-5	TB6-8
TB6-6	TB6-9
TB6-7	TB6-10

SINGLE MODULE 750kVA POWERWARE 9315 UPS SYSTEM CONTROL WIRING INTERCONNECTIONS			
From UPS System (Master)	To Sync Control	Description	Remarks
CUSTTB2-	TB1-10	BYPASS REFERENCE VOLTAGE	Twist Together
CUSTTB2-	TB1-11		
CUSTTB2-5	TB1-7	SYNC VOLTAGE	Twist Together
CUSTTB2-6	TB1-8		
CUSTTB2-7 (*)	TB1-9		

(\*) Requires installation of CK155011-100 to have 750kVA module as master for any other Powerware 9315 system other than another 750kVA unit.

Install the following jumpers, if not connected, on UPS module terminal block CUSTTB2 when installing the Fixed Master Sync Control:

<u>From</u>	<u>To</u>
CUSTTB2-1	CUSTTB2-3
CUSTTB2-2	CUSTTB2-4

Field Wiring Requirements:

- Minimum insulation rating: 600 volts
- Use 14 AWG wiring for interconnections between the Sync Control and the UPS modules.
- Install using Class 1 wiring methods.

DESCRIPTION:	<b>Table 3 – Powerware System Control Wiring Interconnections (Master)</b>	
DRAWING NO:	164201325-11	SHEET: 1 of 2



POWERWARE 9315 UPS HOT SYNC-CAPACITY SYSTEM CONTROL WIRING INTERCONNECTIONS			
From SBM (Master)	To Sync Control	Description	Remarks
TB6-1	TB1-10	BYPASS REFERENCE VOLTAGE	Twist Together
TB6-2	TB1-11		Twist Together
TB6-7	TB1-7	SYNC VOLTAGE	Twist Together
TB6-8	TB1-8		Twist Together
TB6-9	TB1-9		Twist Together

Install the following jumpers, if removed, on SBM terminal block TB6 when installing the Fixed Master Sync Control:

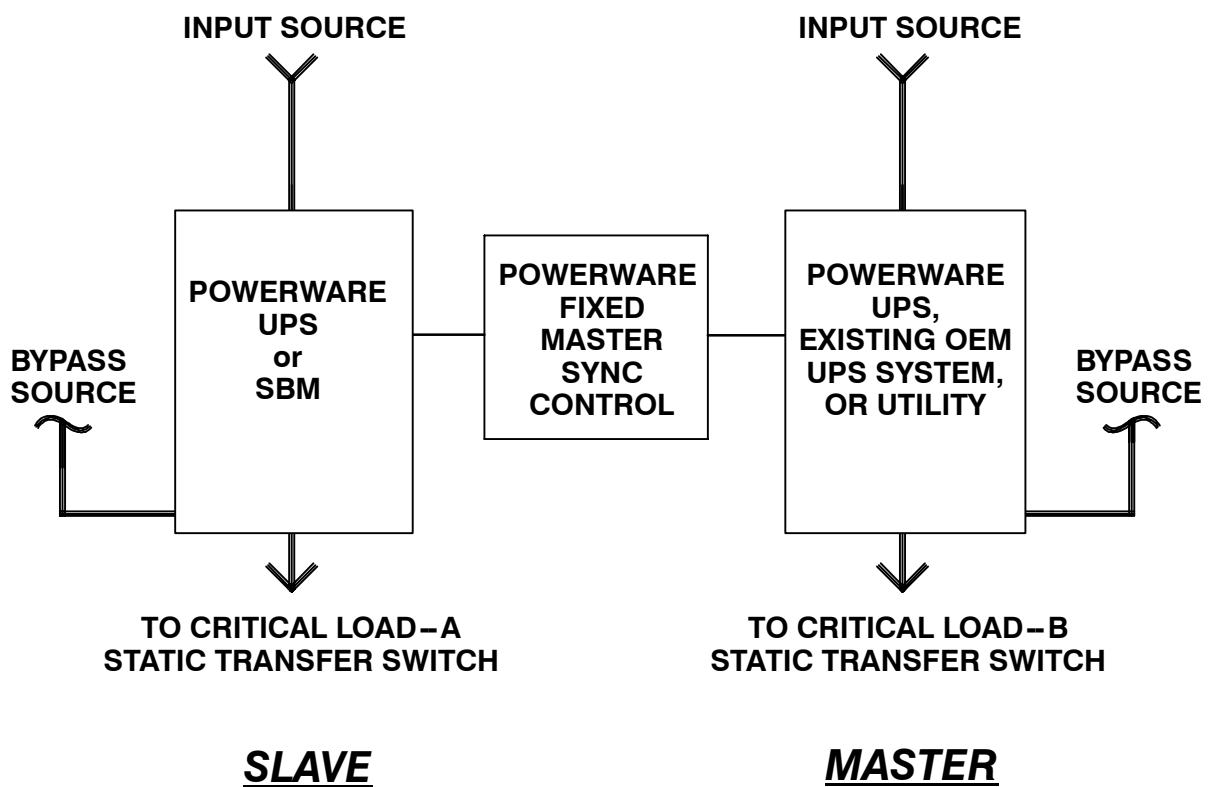
<u>From</u>	<u>To</u>
TB6-1	TB6-4
TB6-2	TB6-5
TB6-3	TB6-6

INTERCONNECTIONS FOR EQUIPMENT OTHER THAN POWERWARE PRODUCTS (Refer to Other Vendor Installation Manual)			
From Master Source	To Sync Control	Description	Remarks
Phase A	TB1-10	BYPASS REFERENCE VOLTAGE (See Note)	Twist Together
Phase B	TB1-11		
Phase A	TB1-7	SYNC VOLTAGE	Twist Together
Phase B	TB1-8		
Phase C	TB1-9		
Note: If using the utility source as master or a source where bypass does not exist, add jumpers to the fixed master sync control as shown below:			
<u>FROM</u>	<u>TO</u>		
TB1-10	TB1-7		
TB1-11	TB1-8		

Field Wiring Requirements:

- Minimum insulation rating: 600 volts
- Use 14 AWG wiring for interconnections between the Sync Control and the UPS modules.
- Install using Class 1 wiring methods.

DESCRIPTION:	<b>Table 3 – Powerware System Control Wiring Interconnections (Master)</b>	
DRAWING NO:	164201325–11	SHEET: 2 of 2



<i>DESCRIPTION:</i>	<b>SIMPLIFIED POWERWARE FIXED MASTER SYNC CONTROL BLOCK DIAGRAM</b>	
<i>DRAWING NO:</i>	164201325-12	<i>SHEET:</i> 1 of 1

**This Page Intentionally Left Blank.**

## LIMITED FACTORY WARRANTY FOR THREE-PHASE POWERWARE PRODUCTS

Subject to the conditions herein, *Invensys Powerware (Powerware®)* warrants solely, to the original end-user, the electronics (the "Unit"), and *Powerware* built battery cabinets, against defects in material and workmanship for the warranty period of 12 months, from the date of equipment start up, or 18 months from date of shipment, whichever occurs first. Should service be necessary, this warranty covers:

USA only: The *Powerware* 9315, 9330, 9335 three-phase UPS products are sold with a standard factory warranty (described below), start up, and extended labor service.

All three-phase UPS installations will have an authorized *Invensys Powerware* Service Engineer or Agent perform startup or the factory warranty and extended labor service will be void. The included first year extended labor service provides for a complete 12 months of onsite labor for your UPS purchase.

Worldwide: All parts requiring replacement for the Factory Warranty period.

If, in the opinion of *Invensys Powerware*, the Unit fails to meet published specifications and the defect is within the terms of this warranty, the Unit will be repaired or replaced at the option of *Invensys Powerware* with no charge for replacement parts. Labor required, to make upgrades, repairs or replacement installation, is not included under the terms of this Limited Warranty, except for labor and travel costs required during the first 90 days of this warranty (USA only), provided that startup of the unit onsite, has been performed by *Invensys Powerware* or its agent. Equipment sold, but not manufactured by *Invensys Powerware*, and only the manufacturer of such equipment shall warrant this equipment and is not included as part of this warranty agreement. Equipment repaired or replaced pursuant to this warranty will be warranted for the remaining portion of the original warranty subject to all the terms thereof.

This warranty is not valid unless an authorized *Invensys Powerware* Service Engineer or Agent performs startup and commissioning. This warranty does not apply to any Unit that has been subject to neglect, accident, abuse, misuse, misapplication, incorrect installation, or that has been subject to repair or alteration, not authorized in writing by *Invensys Powerware* personnel or performed by an authorized *Invensys Powerware* Service Engineer or Agent. Purchaser shall be invoiced for, and shall pay for, all services not expressly provided for by the terms hereof, including, without limitation, site calls involving an inspection that determines no corrective maintenance is required. THIS WARRANTY IS THE PURCHASER'S (USER'S) SOLE REMEDY AND IS EXPRESSLY IN LIEU OF, AND THERE ARE NOT OTHER, EXPRESSED OR IMPLIED GUARANTEES OR WARRANTIES (INCLUDING ANY IMPLIED WARRANTY OF MERCHANTABILITY OR FITNESS FOR ANY PURPOSE, WHICH ARE EXPRESSLY DISCLAIMED). In no case will *Invensys Powerware's* liability under this Warranty exceed the replacement value of the Unit warranted.

*Invensys Powerware's* obligation, under said warranty, is expressly conditioned upon receipt by *Invensys Powerware* of all payments due it (including interest charges, if any). During such time as *Invensys Powerware* has not received payment of any amount due it, in accordance with the Contract terms under which the equipment is sold, *Invensys Powerware* shall have no obligation, under said warranty; also during this time, the period of said warranty shall continue to run and the expiration of said warranty shall not be extended upon payment of the overdue amount. These limitations, to said warranty, apply even in the event that the equipment is sold initially by *Invensys Powerware* for resale to an ultimate end-user.

In no event shall *Invensys Powerware* be liable for any indirect, incidental special or consequential damages of any kind or type whatsoever, or based on any claim or cause of action, however denominated. *Invensys Powerware* shall not be responsible for failure to provide service or parts due to causes beyond *Invensys Powerware's* reasonable control. This limited warranty applies only to the original end user of the unit.

This factory warranty will not be in effect if the End-User does not properly store the equipment, including the "trickle charge" of batteries no later than the date indicated on the packaging, before installation and does not cover shipping damages if FOB Factory. Cost for replacement equipment, installation, material freight charges travel expenses and labor of *Invensys Powerware* representatives will be borne by the Purchaser (user). Any advice furnished the Purchaser before or after delivery in regard to use or application of *Powerware* equipment is furnished without charge and on the basis that it represents *Invensys Powerware's* best judgment under the circumstances. The use of any such advice by the Purchaser is solely and entirely at its own risk. Any other agreements, such as Service contracts or Sales Concessions are not means to annul this Factory Warranty.

For comment or questions, about this Limited Factory Warranty, write to the Customer Quality Representative, 3301 Spring Forest Road, Raleigh, NC 27601, or call (919) 872-3020

**This Page Intentionally Left Blank.**



164201325 Rev A