



ИБП Powerware 9315 - Руководство по установке Powerware 9315 100kVA - 160kVA UPS

Постоянная ссылка на страницу: <https://eaton-power.ru/catalog/powerware-9315/>



POWERWARE[®]

9315

*Uninterruptible Power
Supply*

100 kVA - 160 kVA

Installation
Manual

164200292 Rev. E

IMPORTANT SAFETY INSTRUCTIONS

Instructions Importantes Concernant La Sécurité

SAVE THESE INSTRUCTIONS

Conserver Ces Instructions

This manual contains important instructions for your Uninterruptible Power Supply (UPS) system. You should follow these instructions during the installation and maintenance of the UPS, options, accessories, and batteries.

Cette notice contient des instructions importantes concernant la sécurité.

This equipment has been tested and found to comply with the limits for a Class A digital device, pursuant to Part 15 of the FCC Rules. These limits are designed to provide reasonable protection against harmful interference when the equipment is operated in a commercial environment. This equipment generates, uses, and can radiate radio frequency energy and, if not installed and used in accordance with the instruction manual, may cause harmful interference to radio communications. Operation of this equipment in a residential area is likely to cause harmful interference in which case the user will be required to correct the interference at their own expense.

WARNING:

This is a product for restricted sales distribution to informed partners. Installation restrictions or additional measures may be needed to prevent disturbances.

Table of Contents

1 Introduction	1
Using This Manual	2
Conventions Used in This Manual	3
For More Information	3
Getting Help	3
2 Getting Started	5
Preparing Your Site	6
Environment Considerations	6
Preparing for Wiring the UPS System	6
Inspecting and Unpacking Each Cabinet	7
Unloading the UPS Cabinet From the Pallet	8
Creating an Installation Plan	10
3 Installing the UPS	11
Preparing the UPS for Installing Optional Cabinets or Accessories	13
Completing the Installation Checklist	15
Installation Checklist	16
Notes	17
4 Joining Cabinets	19
Method A – Joining an Optional Cabinet to the UPS	20
Method B – Joining Optional Cabinets to Each Other	23
Grounding Joined Cabinets	25
Method A Grounding	25
Method B Grounding	25
5 Installing Battery Cabinets	27
Two Models are Available	27
Important Safety Instructions	27
General Notes About Installing Battery Cabinets and Remote Disconnects	28

6	Installing an Input Transformer	29
7	Installing a Power Distribution Module	33
8	Installing a Remote EPO Control	37
9	Installing a Remote Battery Disconnect	39
10	Installing a Remote Monitor Panel	41
11	Installing a Relay Interface Module	47
12	Installing a Supervisory Contact	51
	Appendix A – Customer Information	A–1

Powerware 9315 (100 kVA-160 kVA) Installation
164200292 REV. E 041500

List of Figures

Figure 1.	Typical UPS System	1
Figure 2.	Cabinet as Shipped, with Outer Packaging and Pallet	7
Figure 3.	Removing Front and Rear Supports	9
Figure 4.	UPS Cabinet	11
Figure 5.	Preparing the UPS for Installing Other Cabinets	14
Figure 6.	Methods of Joining Cabinets	19
Figure 7.	Joining an Optional Cabinet to the UPS	20
Figure 8.	Pushing Cabinets Together	20
Figure 9.	Placement of Joining Brackets	21
Figure 10.	Installing the Angled Bracket	22
Figure 11.	Preparing to Join Component Cabinets	23
Figure 12.	Joining Component Cabinets	24
Figure 13.	Cabinet-to-Cabinet Grounding – Method A	26
Figure 14.	Cabinet-to-Cabinet Grounding – Method B	26
Figure 15.	Input Transformer Cabinet	29
Figure 16.	Installing an Input Transformer Cabinet	31
Figure 17.	Typical PDM Cabinet	33
Figure 18.	Remote EPO Control	37
Figure 19.	Remote Battery Disconnect Enclosure	39
Figure 20.	Remote Monitor Panel (RMP)	42
Figure 21.	Terminal Block Bracket	43
Figure 22.	Wiring an RMP to the UPS	44
Figure 23.	Relay Interface Module	47
Figure 24.	Terminal Block Bracket	48
Figure 25.	Wiring an RIM to the UPS	48
Figure 26.	Supervisory Contact Module	51
Figure 27.	Terminal Block Bracket	52
Figure 28.	Wiring an SCM to the UPS	52
Figure 29.	Supervisory Contact Module TB2	54

This Page Intentionally Left Blank.

1

Introduction

This manual describes how to install your Powerware® 9315 Uninterruptible Power Supply (UPS) system. It contains instructions for installing the UPS and each optional component and accessory. The information you will use depends on the system you purchased.

Each component of your UPS system is housed in a free-standing cabinet. The cabinets line up and match in style and color, and have safety shields behind the doors for hazardous voltage protection. Figure 1 shows a sample UPS system that includes at least one of each component.

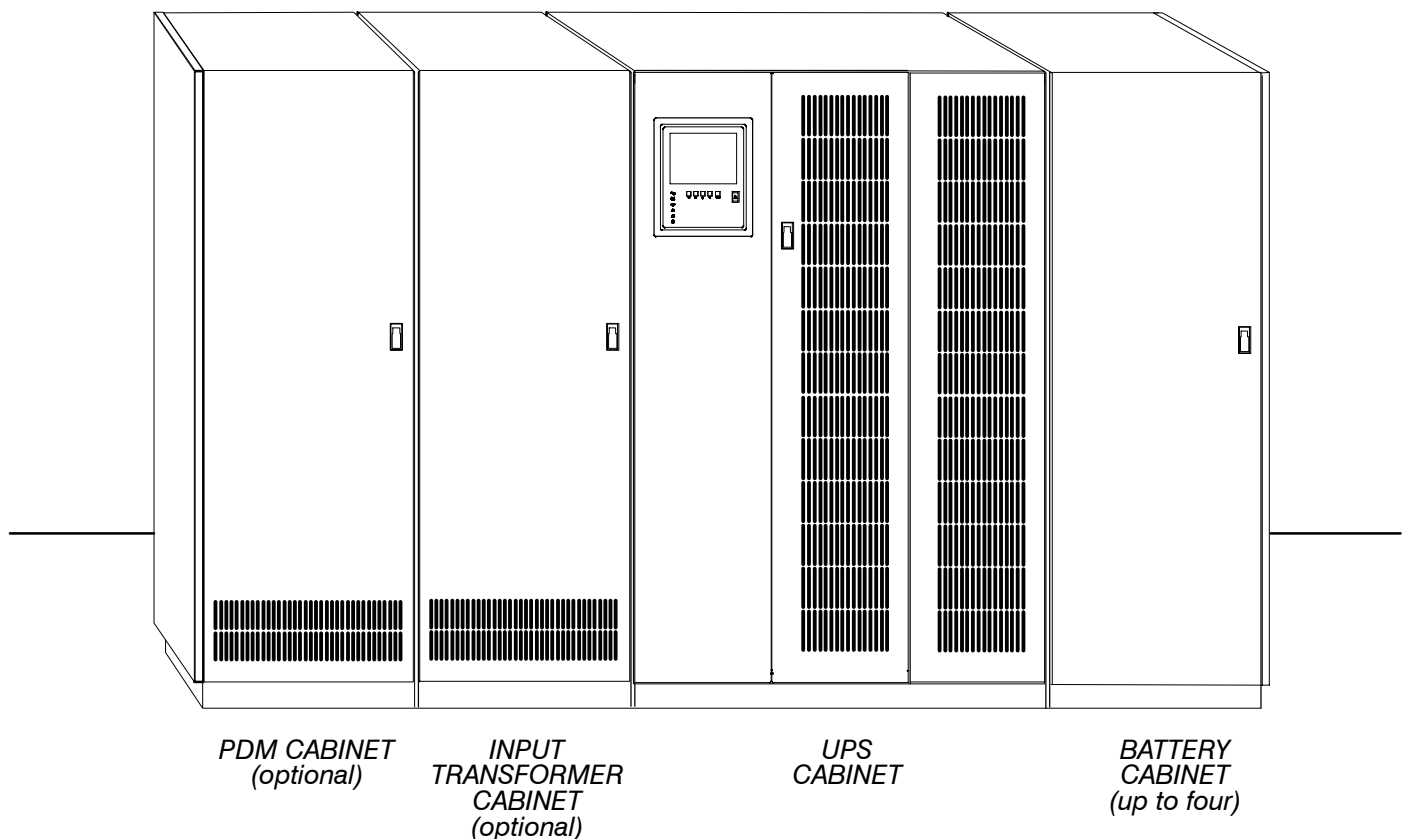

Figure 1. Typical UPS System

These basic UPS system configurations are possible:

- The UPS and one or more battery cabinets
- The UPS, battery cabinet(s), and a Power Distribution Module (PDM)
- The UPS, battery cabinet(s), and an input transformer
- The UPS, battery cabinet(s), PDM, and input transformer.

You can enhance any of these system configurations by adding optional accessories, such as a *Remote Monitor Panel (RMP)*, *Relay Interface Module (RIM)*, or *Remote Emergency Power Off (EPO)* control.

Using This Manual

The system you are installing dictates which parts of this manual you should read. Everyone should read Chapters 1 through 4:

- Chapter 1 discusses installation considerations for your entire UPS system.
- Chapter 2 tells you how to prepare your site for the installation of your UPS system. It discusses equipment environmental requirements, inspecting and unpacking cabinets, and pallet removal.
- Chapter 3 describes how to install the UPS cabinet.
- Chapter 4 illustrates the two methods for joining cabinets together.
- Chapter 5 contains safety instructions and general notes for installation of the UPS manufacturer's optional battery cabinets.
- Chapter 6 contains information for installing the optional input transformer cabinet.
- Chapter 7 contains information for installing the optional Power Distribution Module (PDM).
- Chapter 8 discusses installing the optional Remote Emergency Power Off (EPO) control.
- Chapter 9 contains information for installing the optional remote battery disconnect.
- Chapter 10 contains information for installing the optional Remote Monitor Panel (RMP).
- Chapter 11 contains information for installing the optional Relay Interface Module (RIM).
- Chapter 12 contains information for installing the optional Supervisory Contact Module (SCM).
- Appendix A contains important information for planning and installing your UPS system, including illustrations of cabinets and optional accessories.

Read through each installation procedure before you begin. Perform only those procedures that apply to the UPS system you are installing.

Conventions Used in This Manual

The text in this manual uses these conventions:

- **Bold type** highlights important concepts in discussions, key terms in procedures, and menu options.
- *Italic type* highlights notes and new terms where they are defined.
- Rectangular boxes containing bold type are warnings or cautions that pertain to the UPS system or its electrical connections.

In this manual, the term *UPS* refers only to the UPS cabinet and its internal elements. The term *UPS system* refers to the entire power protection system—the UPS cabinet plus any options or accessories you have installed.

For More Information

This manual describes how to install your UPS system. For more information about the operation and communications capabilities of the UPS system, refer to the following:

164200252

Powerware® 9315 30 kVA – 160 kVA UPS Operation

Describes the UPS cabinet Control Panel and Monitor Panel, and explains the functions of the UPS; discusses the standard features of the UPS and optional accessories; provides procedures for starting and stopping the UPS, and information about maintenance and responding to system events.

Also described are the RS–485 and RS–232 serial communications capabilities of the UPS system; discusses the two communications ports on the Customer Interface Panel inside the UPS and how to connect optional remote accessories to your UPS system; provides information about enabling, disabling, and customizing building alarms.

Contact your local Field Service office for information on how to obtain copies of this manual.

Getting Help

If you have a question about any of the information in this manual, or if you have a question this manual does not answer, please call Powerware Corporation Field Service:

United States

1-800-843-9433

Canada

1-800-461-9166

Outside the U.S.

Call your local representative

This Page Intentionally Left Blank.

2

Getting Started

Each cabinet of your UPS system is shipped on a separate pallet. Use a forklift or pallet jack to move the packaged cabinets to the installation site, or as close as possible to the site, before you unload them from the pallets.

This is the basic sequence of the installation steps:

1. Prepare your site for the UPS cabinet (Chapter 2).
2. Inspect, unpack, and unload the UPS cabinets (Chapter 2).
3. Create an installation plan for the UPS and optional cabinets (Chapter 3).
4. Join the cabinets together using supplied hardware (Chapter 4).
5. Wire the cabinets together (Chapters 5–12, as applicable).
6. Install features, accessories, and/or options (Chapters 5–12, as applicable).
7. Complete the Installation Checklist (Chapter 3).
8. Have authorized service personnel perform preliminary checks and startup.

After wiring the UPS system to the facility power and critical load(s), be sure to ground the system according to local and/or national electrical wiring codes, using your own cabling and conduit.

Install batteries in accordance with all applicable codes and regulations, including the National Electrical Code (NEC), Article 480.

NOTE: *Startup and operational checks should be performed only by authorized service personnel. This service is usually offered as part of the sales contract for your UPS system.*

Preparing Your Site

For your UPS system to operate at peak efficiency, your installation site should meet the environmental parameters outlined in the operator's manual for the UPS. If you intend to operate the UPS at an altitude higher than 1500 meters (5000 feet), contact your local sales or service office for important information about high altitude operation. The operating environment must meet the size and weight requirements shown in Table R of Appendix A.

The basic environmental requirements for operation of the UPS system are:

Ambient Temperature Range: 0–40° C (32–104° F)

Recommended Operating Range: 20–25° C (68–77° F)

Maximum Relative Humidity: 95%

The UPS cabinet uses forced air cooling to regulate internal component temperature. The battery and optional component cabinets use convection cooling to regulate internal component temperature. Air inlets are in the front of the cabinet, and outlets are in the top. You must allow clearance in front of and above each cabinet for proper air circulation.

Environment Considerations

The life of the UPS system will be adversely affected if the installation does not meet the following guidelines:

1. The UPS system must be installed on a sealed concrete pad on a sealed concrete floor.
2. The UPS system must be installed in a dust-free environment.
3. The UPS system must be installed in a humidity-controlled environment.

Preparing for Wiring the UPS System

For external wiring requirements, including the minimum AWG size of external wiring, see Tables J through L in Appendix A. The power wiring for this equipment is rated at 75°C. If wire is run in an ambient temperature greater than 30°C, higher temperature and/or larger size wire may be necessary. Wiring for optional accessories (such as a Remote Monitor Panel (RMP) or Relay Interface Module (RIM)) should be installed through the 28.6 mm (1.1 in.) knockout in the bottom of the UPS cabinet. The top entry connection requires installation of ½-in. flexible conduit within the UPS. Bottom entry connection requires no additional routing of conduit within the UPS.

Inspecting and Unpacking Each Cabinet

The first task in preparing for installation is inspecting and unpacking each cabinet. Cabinets arrive covered with protective packaging material as shown in Figure 2.

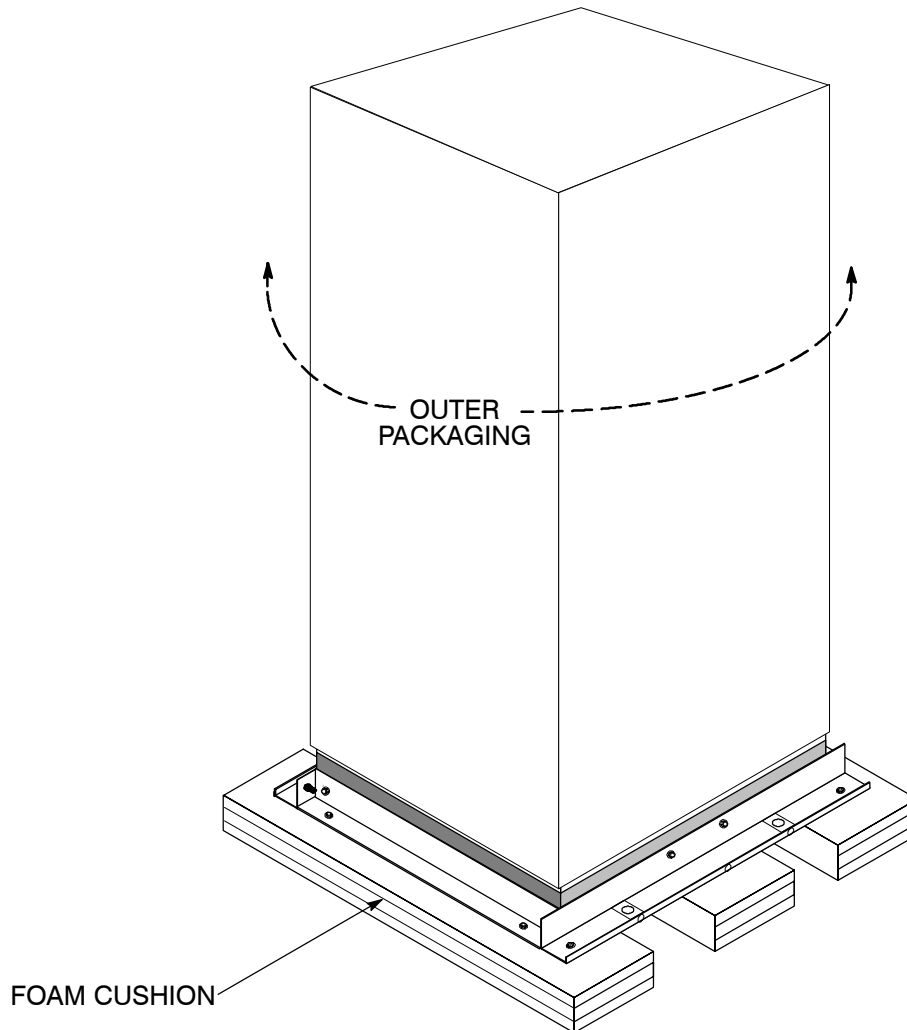

Figure 2. Cabinet as Shipped, with Outer Packaging and Pallet

1. Carefully inspect the outer packaging for evidence of damage during transit.

CAUTION:
Do not install a damaged cabinet. Report any damage to the carrier and contact your local sales or service office immediately.

2. Use a forklift or other material handling equipment to move the cabinet to a convenient unpacking area. Insert the forklift jacks between the foam cushions on the bottom of the unit.

CAUTION:
Do not tilt cabinets more than 10 degrees from vertical.

3. Set each pallet on a firm, level surface, allowing a minimum clearance of 4.6m (15 ft) on each side for removing the cabinets from the pallets.
4. Cut the steel bands around each cabinet.
5. Remove the protective cardboard covering from the cabinets, cutting where indicated, using a knife blade no longer than 25 mm (1 in.).

NOTE: *Do not discard the packaging material yet. Instructions for unloading the cabinet from the pallet are printed on the cardboard, and you will need to refer to them.*

6. Remove the plastic bag and foam packing material, and discard or recycle them in a responsible manner.

Unloading the UPS Cabinet From the Pallet

The UPS cabinet is bolted to a sheet metal pallet consisting of four supports secured to foam cushions. The foam cushions act as shock absorbers for the cabinet during shipment.

WARNING:

UPS cabinets are extremely heavy. If unloading instructions are not closely followed, the cabinet may tip and cause serious injury.

Turning the jacking bolts unevenly may cause the cabinet to become unbalanced. To prevent tipping, raise and lower the jacking bolts evenly. The cabinet should only be raised approximately 3 mm (1/8 in.) above the floor (just enough to remove foam cushions).

1. Remove the doors. Remove the retaining screw located inside each door at the bottom hinge pivot point, then lift the door off. Save the retaining screws for reinstallation of the doors.
2. Locate the field kit (packed inside of the cabinet or communications panel). Locate the four ½-in. jacking bolts and install them in the threaded holes in the front and rear supports. Place a floor protector underneath each jacking bolt, and screw the bolts down against them. The floor protectors will save the floor from being marred by the jacking bolts.
3. Loosen, but do not remove the hardware holding the foam cushions to the front and rear supports (labeled “1” in Figure 3).
4. Turn each jacking bolt consecutively, two full turns, until the foam cushions clear the floor by approximately 3 mm (1/8 in.).
5. After the foam cushions clear the floor, remove the hardware loosened in step 3. Pull the foam cushions out from under the UPS cabinet, and discard or recycle them in a responsible manner.

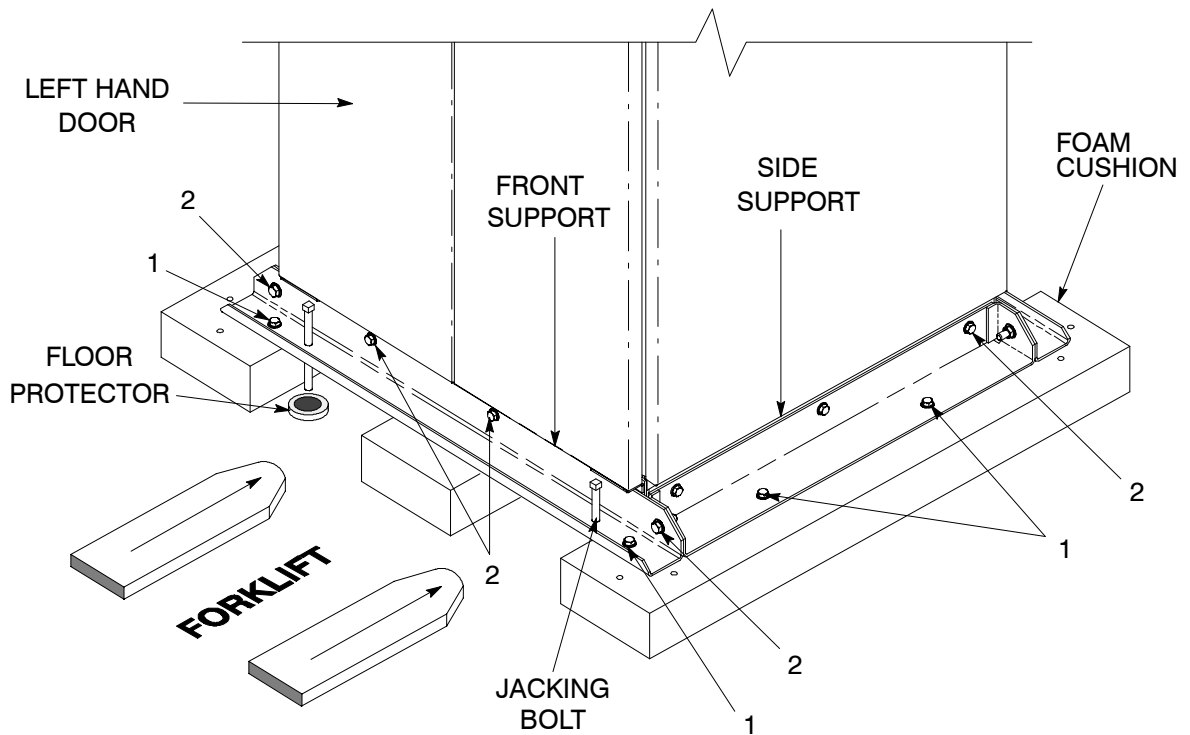

Figure 3. Removing Front and Rear Supports

WARNING:

Cabinet may fall. Do not loosen hardware attaching the side or front supports to the cabinet base. Also, do not loosen supports from each other. The cabinet must be lowered using jacking bolts before supports can be removed.

6. Carefully and evenly lower the cabinet by turning each jacking bolt consecutively two full turns (maximum) until the supports contact the floor, and the cabinet is no longer supported by the jacking bolts.
7. After the UPS cabinet is resting on the floor, remove the jacking bolts and discard or recycle them in a responsible manner.
8. Remove the hardware labeled “2” in Figure 3, holding the front, rear and side supports to the cabinet base. Discard or recycle the hardware and support brackets in a responsible manner.
9. Replace the doors removed in step 1. The UPS cabinet is now ready to be rolled to its final location.
10. Repeat steps 1 through 9 for each cabinet you are preparing to install.

Creating an Installation Plan

Before beginning to install your UPS system, you should be sure you understand the portions of this manual that apply to your system. Use the procedures and illustrations in the following sections to create a logical plan for installing the UPS and optional components. The information in Chapter 3 will help you plan the installation.

3

Installing the UPS

After you unpack, inspect, and move your UPS to its installed location, you are ready to prepare for installation. The UPS cabinet arrives as shown in Figure 4.

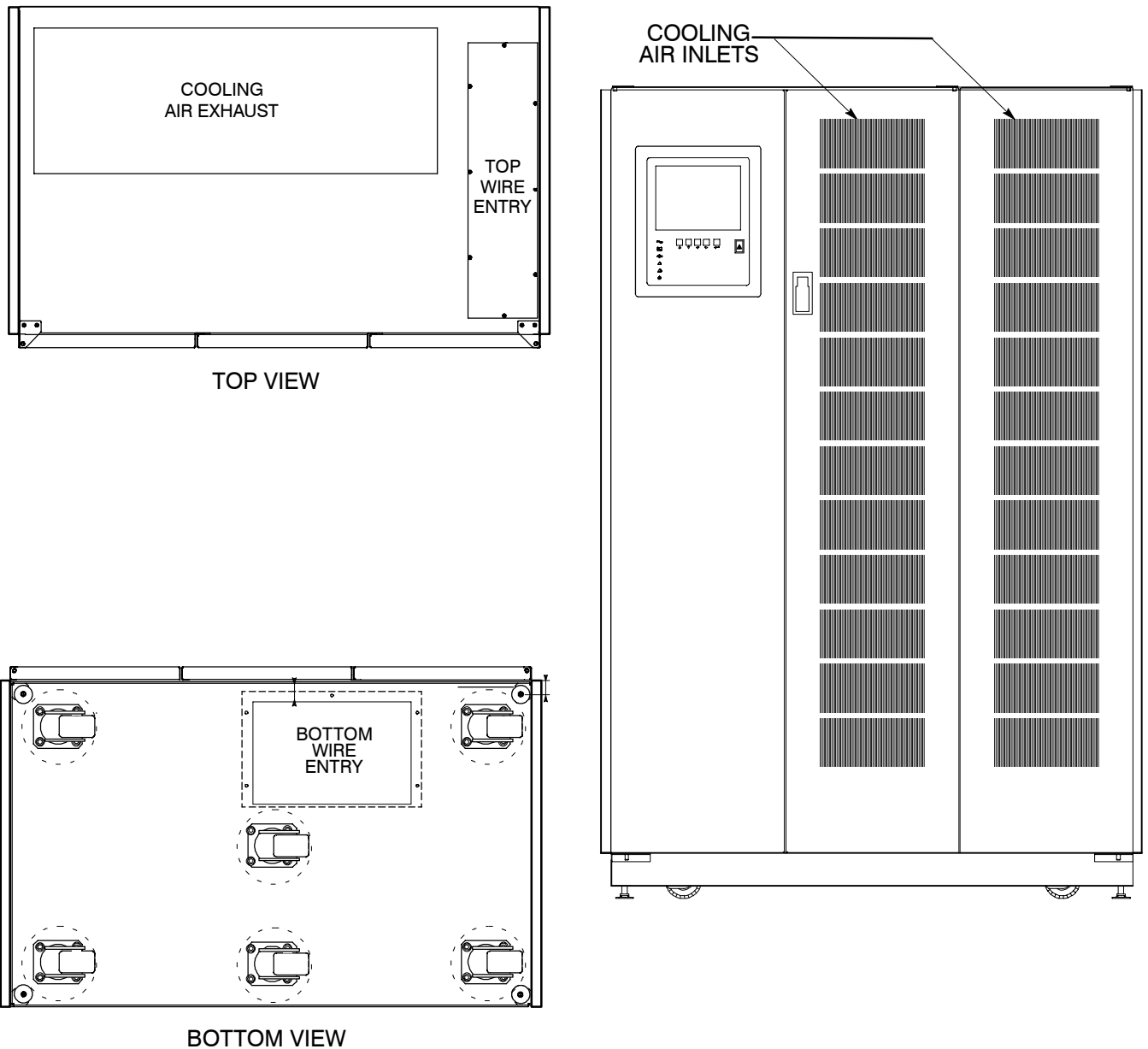

Figure 4. UPS Cabinet

Refer to the following while installing the UPS:

- Dimensions in this manual are in millimeters and inches.
- Do not tilt the UPS or other cabinets more than $\pm 10^\circ$ during installation.
- Cooling exhaust airflow is approximately 920.0 L/S (1950 CFM).
- The conduit landing plates are to be removed to add conduit landing holes as required. Plate material is 16 gauge steel (0.06 in. thick).
- Terminals E1–E15 are UL and CSA rated at 90°C. A hex key tool is required to attach wires to the terminals.
- The Remote Emergency Power Off (EPO) feature opens all breakers and contactors in the UPS cabinet and isolates power from your critical load. Local electrical codes may also require tripping upstream protective devices to the UPS.
- If perforated floor tiles are required for ventilation, place them in front of the UPS. Refer to Table R in Appendix A for equipment weight and point loading.
- Details about control wiring are provided in each procedure for connecting options and features. Table U in Appendix A identifies the control wiring terminations.
- Refer to the Powerware 9315 Maintenance Bypass Module (MBM) Installation and Operation Manual 164201177 for MBM installation.

Preparing the UPS for Installing Optional Cabinets or Accessories

If you are installing optional cabinets or accessories, such as a Power Distribution Module (PDM) cabinet, an input transformer cabinet, or a Remote Monitor Panel (RMP), you must prepare the UPS cabinet for the installation of these options. Refer to Figure 5 for the locations of the items mentioned in these procedures. Also, refer to *Powerware 9315 Series 685 and 1085 Auxiliary Battery Cabinets Installation Manual*, 164200300, for information on installing battery cabinets.

To prepare the UPS for joining to an input transformer, PDM, or both:

1. Be sure the UPS is turned off and all power sources are removed. (See the operator's manual for instructions.)
2. Remove the left side panel of the UPS and set it aside.
3. Open the doors of the UPS.
4. Remove the air filters and set aside for later reuse.
5. Remove the lower metal access panel (see Figure 5 for location). Set the access panel and hardware aside for later reuse.

To prepare the UPS for wiring to an RMP, RIM, SCM, or Remote EPO:

1. Be sure the UPS is turned off and all power sources are removed. (See the operator's manual for instructions.)
2. Open the doors of the UPS.
3. Remove the air filters and set aside for later reuse.
4. Remove the lower metal access panel (see Figure 5 for location). Set the access panel and hardware aside for later reuse.

LEFT SIDE PANEL

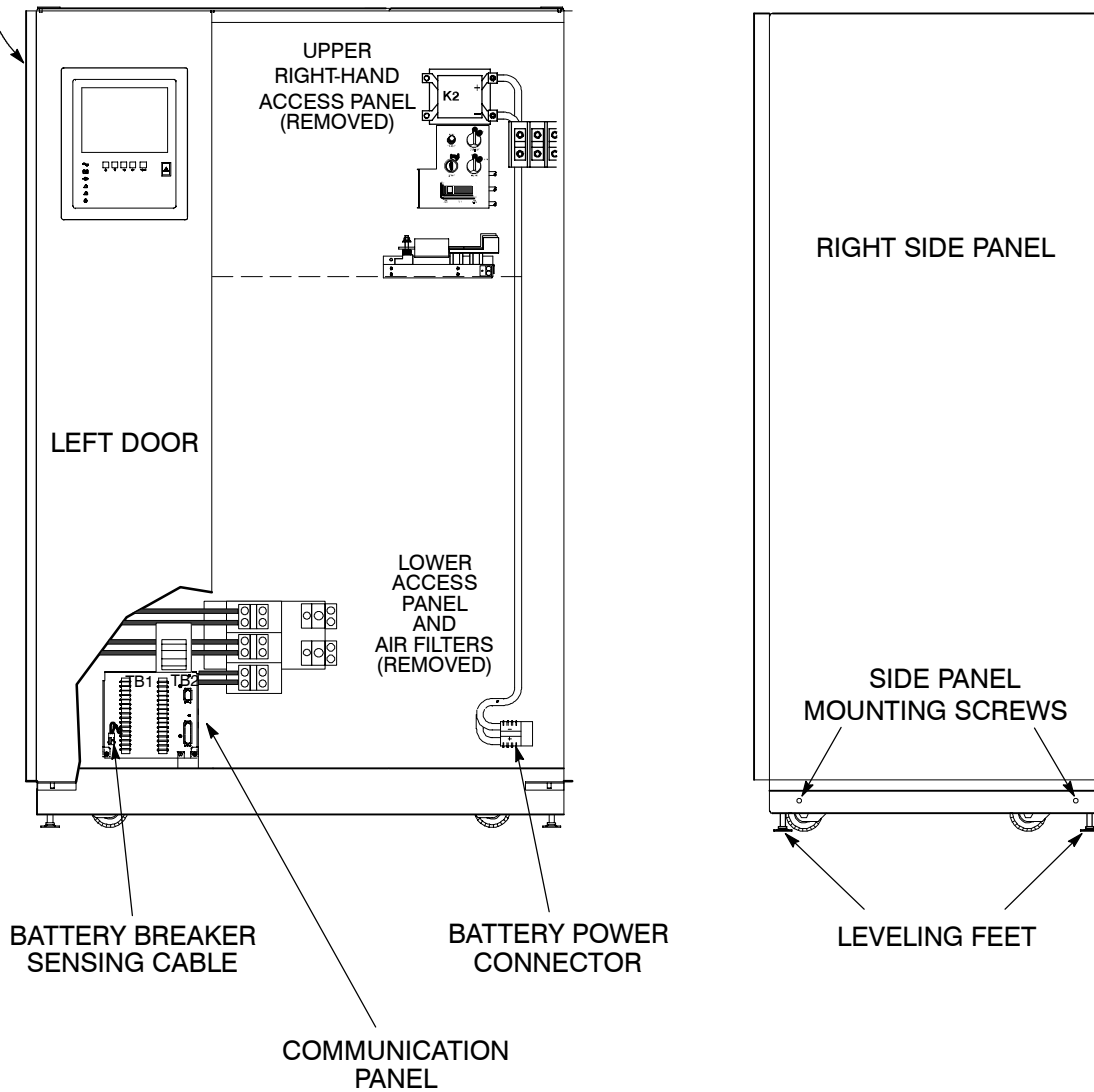

NOTE: UPS Shown with Right Door Open or Removed

Figure 5. Preparing the UPS for Installing Other Cabinets

Completing the Installation Checklist

The final step in installing your UPS system is completing the following Installation Checklist. This checklist ensures that you have completely installed all hardware, cables, and other equipment. Completing all items listed on the checklist will ensure a smooth installation. You should make a copy of the Installation Checklist before filling it out, and retain the original.

After your installation is complete, a service representative will be able to verify the operation of your UPS system and commission it to support your critical load. The service representative cannot perform any installation tasks other than verifying software and operating setup parameters. Service personnel may request a copy of the completed Installation Checklist to be sure you have completed all applicable equipment installation.

NOTE: *The Installation Checklist MUST be completed prior to starting the UPS system for the first time.*

Installation Checklist

- All packing materials and restraints have been removed from each cabinet.
- Each cabinet in the UPS system is placed in its installed location.
- All cabinets (except stand-alone cabinets) are bolted together.
- A ground bond is installed between all cabinets that are bolted together.
- All switchboards, conduits, and cables are properly routed to the UPS and auxiliary cabinets.
- Power cables are terminated on bypass terminals (E6–E8 on 480V systems, E13–E15 on all other systems).
- Power cables are terminated on the CB1 input breaker (E1–E3 on 480V systems, E13–E15 on all other systems).
- A ground conductor is properly installed.
- If neutral connection is used, no other N–G bonds exist downstream from the UPS.
- Battery cables and harness are terminated on the K2 battery contactor E4 and E5.
- Internal battery cabinet connections have been completed (bus bars, plugs, etc.).
- Air conditioning equipment is installed and operating correctly.
- The area around the installed UPS system is clean and dust-free. (It is recommended that the UPS be installed on a sealed concrete pad on a sealed concrete floor.)
- Adequate workspace exists around the UPS and other cabinets.
- Adequate lighting is provided around all UPS equipment.
- A 120V service outlet is located within 25 feet of the UPS equipment.
- Each Remote Monitor Panel (RMP) is mounted in its installed location. (OPTIONAL)
- The control wiring for each RMP is terminated inside the UPS cabinet. (OPTIONAL)
- The Remote Emergency Power Off (EPO) device is mounted in its installed location and its wiring terminated inside the UPS cabinet. (OPTIONAL)
- Summary alarms and/or building alarms are wired appropriately. (OPTIONAL)
- A Relay Interface Module (RIM) is mounted in its installed location and its wiring is terminated inside the UPS cabinet. (OPTIONAL)
- A remote battery disconnect control is mounted in its installed location and its wiring is terminated inside the UPS and battery cabinet. (OPTIONAL)

This Page Intentionally Left Blank.

4

Joining Cabinets

The method you use to join two cabinets depends on which cabinets they are. For the purpose of discussion, this chapter uses the term *UPS* to refer to the UPS cabinet, and the term *optional cabinet* to refer to any other cabinet (such as an input transformer or PDM cabinet). There are two different procedures for joining the cabinets in your UPS system:

- **Method A** – Joining an optional cabinet to the UPS
- **Method B** – Joining two optional cabinets to each other

Figure 6 shows which method you should use for each cabinet. The UPS system shown in Figure 6 includes a UPS and one of each optional cabinet. As the figure shows, you should remove the cosmetic covers from the sides of all cabinets except the outermost right and left cabinets of a line-up-and-match system. (Do not remove the cosmetic covers from the sides of stand-alone cabinets.)

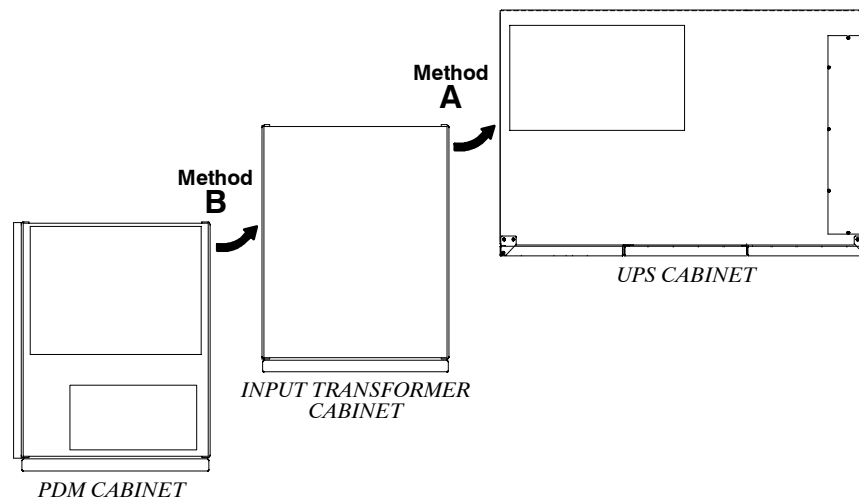

Figure 6. Methods of Joining Cabinets

Use the appropriate method to join each cabinet in the position shown in Figure 6:

- Use Method A to join the **input transformer** cabinet to the left side of the UPS cabinet.
- Use Method B to join the **PDM cabinet** to the left side of the input transformer cabinet (if present). If you do not have an input transformer cabinet, use Method A to join the PDM cabinet to the left side of the UPS cabinet.
- Refer to *Powerware 9315 Series 685 and 1085 Auxiliary Battery Cabinets Installation Manual*, 164200300, for procedures to connect battery cabinets.

Method A – Joining an Optional Cabinet to the UPS

Use this procedure to join any optional cabinet to the UPS:

1. Secure the UPS with its leveling feet.
2. Roll the optional cabinet to a spot near the UPS, in any one of the three positions shown in Figure 7. A PDM or input transformer cabinet should be joined to the left side of the UPS.

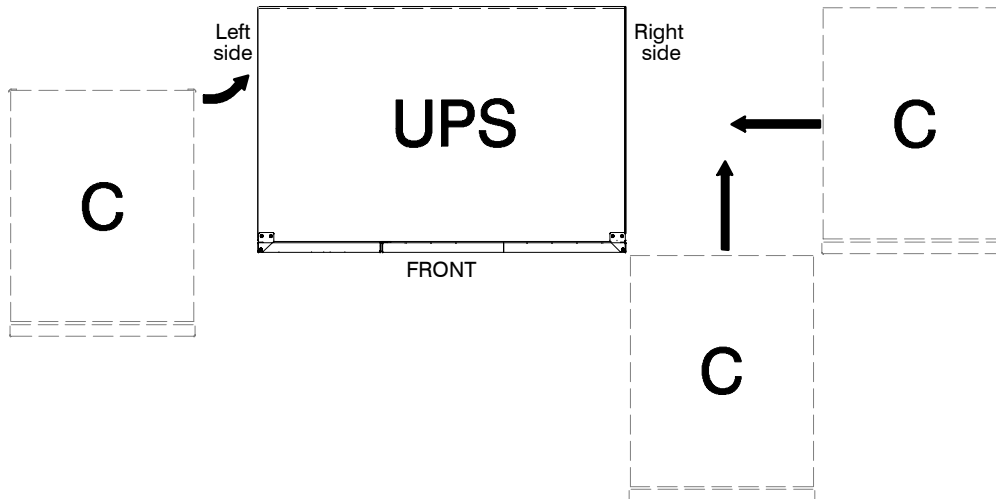

Figure 7. Joining an Optional Cabinet to the UPS

3. Remove the cosmetic covers from the two cabinet sides you are joining.
4. Push the optional cabinet toward the UPS cabinet until both cabinets are aligned at the rear. Figure 8 shows two optional cabinets pushed into place and aligned with the rear of the UPS cabinet.

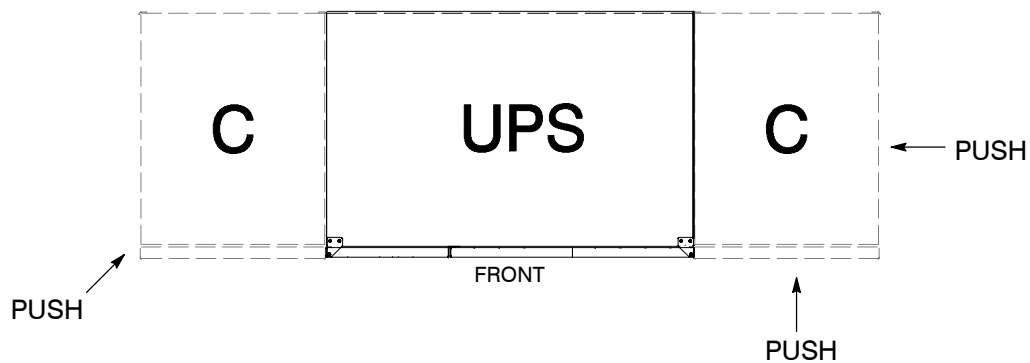

Figure 8. Pushing Cabinets Together

5. Three cabinet joining brackets are provided for securing each cabinet at the top and bottom. Two flat brackets connect the tops of the cabinets, one at the front and one at the back. The bottom bracket type is dependent on cabinet configuration. See Figure 9 and Figure 10. Either an angled bracket or a larger flat bracket joins the cabinets at the bottom. Attach the flat brackets to the cabinet tops first.

NOTE: The following steps describe how to join an optional cabinet to the left side of the UPS.

6. Remove the screw from the top door hinge of the UPS cabinet. Remove the hex head screw from the front hole in the top frame angle on the optional cabinet. Align the small hole in one flat bracket over the screw hole in the cabinet hinge, and the large hole over the hole in the optional cabinet frame. Install the screws (see Figure 9).

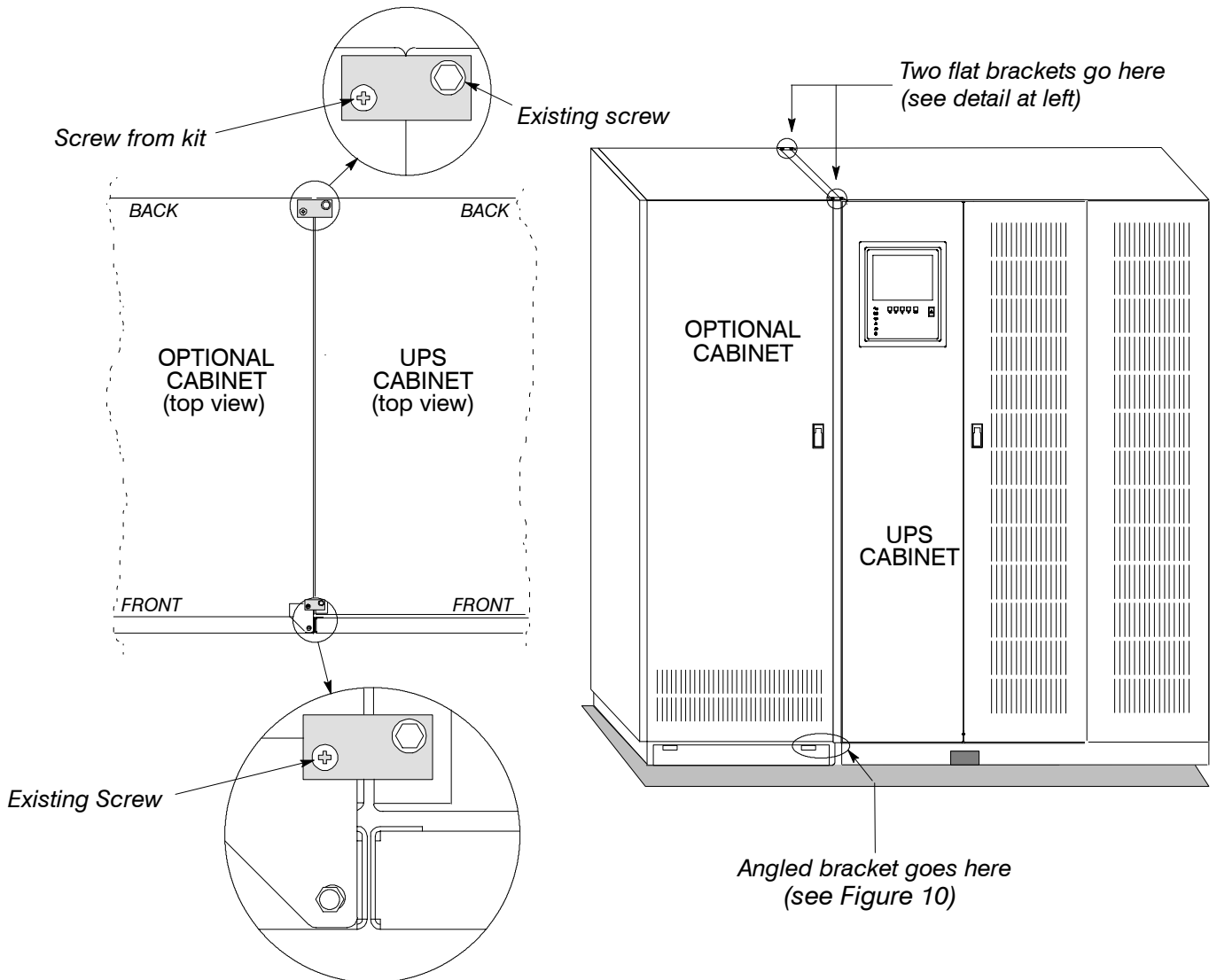

Figure 9. Placement of Joining Brackets

NOTE: When cabinets are properly aligned, all cabinet doors will be flush with each other.

7. Use the same method as step 6 to install the second flat bracket over the screws at the rear of the cabinet tops.
8. Remove the nut from the screw in the lower door hinge of the UPS cabinet.

9. Hold the angled bracket parallel to the floor (see Figure 10). The flange with the hole in it (labeled **A** in Figure 10) should be facing upward. The flange with the tab (labeled **B** in Figure 10) should be pointing toward the slot in the base of the optional cabinet.

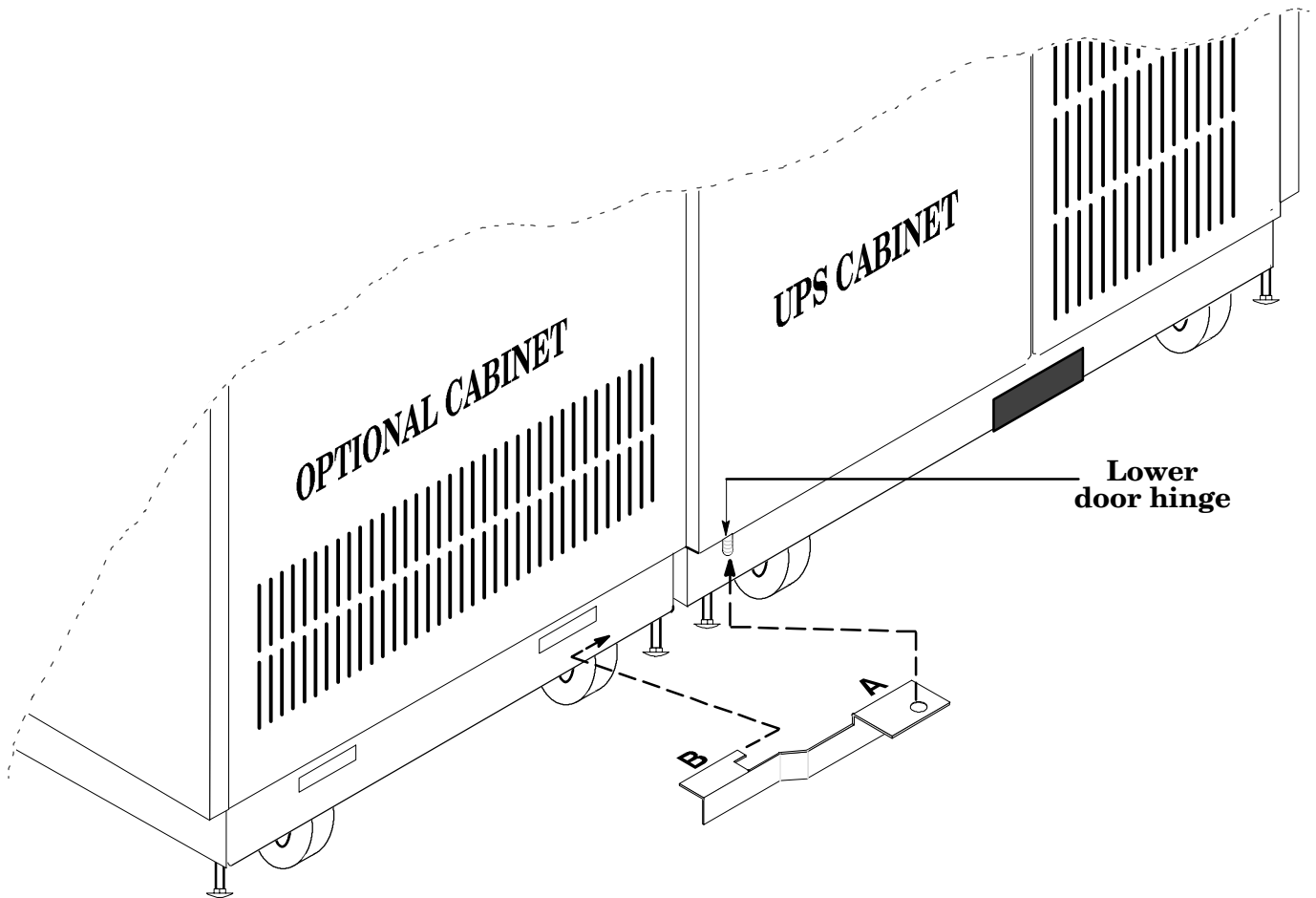

Figure 10. Installing the Angled Bracket

10. Insert the tab (**B**) into the slot in the base of the optional cabinet.
11. Slide the bracket toward the UPS cabinet while slipping the hole (**A**) onto the screw in the lower door hinge of the UPS cabinet.
12. Install the nut (removed in step 8) on the hinge screw to secure the angled bracket in place.
13. Repeat steps 2 through 12 to join another optional cabinet to the other side of the UPS cabinet.
14. Attach a ground wire to the joined cabinets using the procedure “*Grounding Joined Cabinets*” in this chapter.

Method B – Joining Optional Cabinets to Each Other

Use this procedure to join any two optional cabinets. (See Figure 15 or Figure 17 for location of joining points.)

1. Remove the cosmetic covers from the sides of the cabinets to be joined.
2. Roll cabinet #1 to its final position and lower the leveling feet for anchoring.
3. Roll cabinet #2 to the position shown in Figure 11.

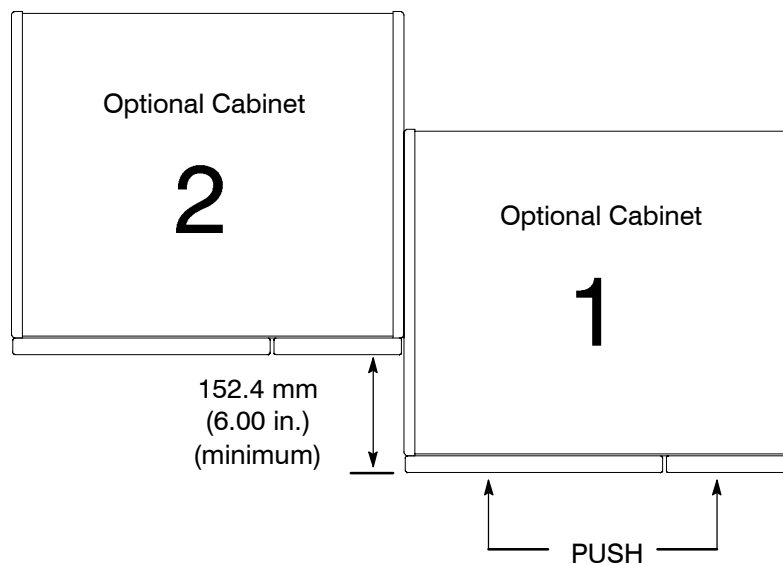

Figure 11. Preparing to Join Component Cabinets

4. Push cabinet #2 from the front until both cabinets are aligned at the rear (as shown in Figure 12). This action will seat the rear-joining clamps.
5. Locate the hardware joining kit taped to the top of either cabinet. Using two hex head bolts and two hex head nuts from the hardware joining kit, secure the fronts of the two cabinets as shown in Figure 12.
6. Attach a ground to the joined cabinets using the procedure “*Grounding Joined Cabinets*” in this chapter.

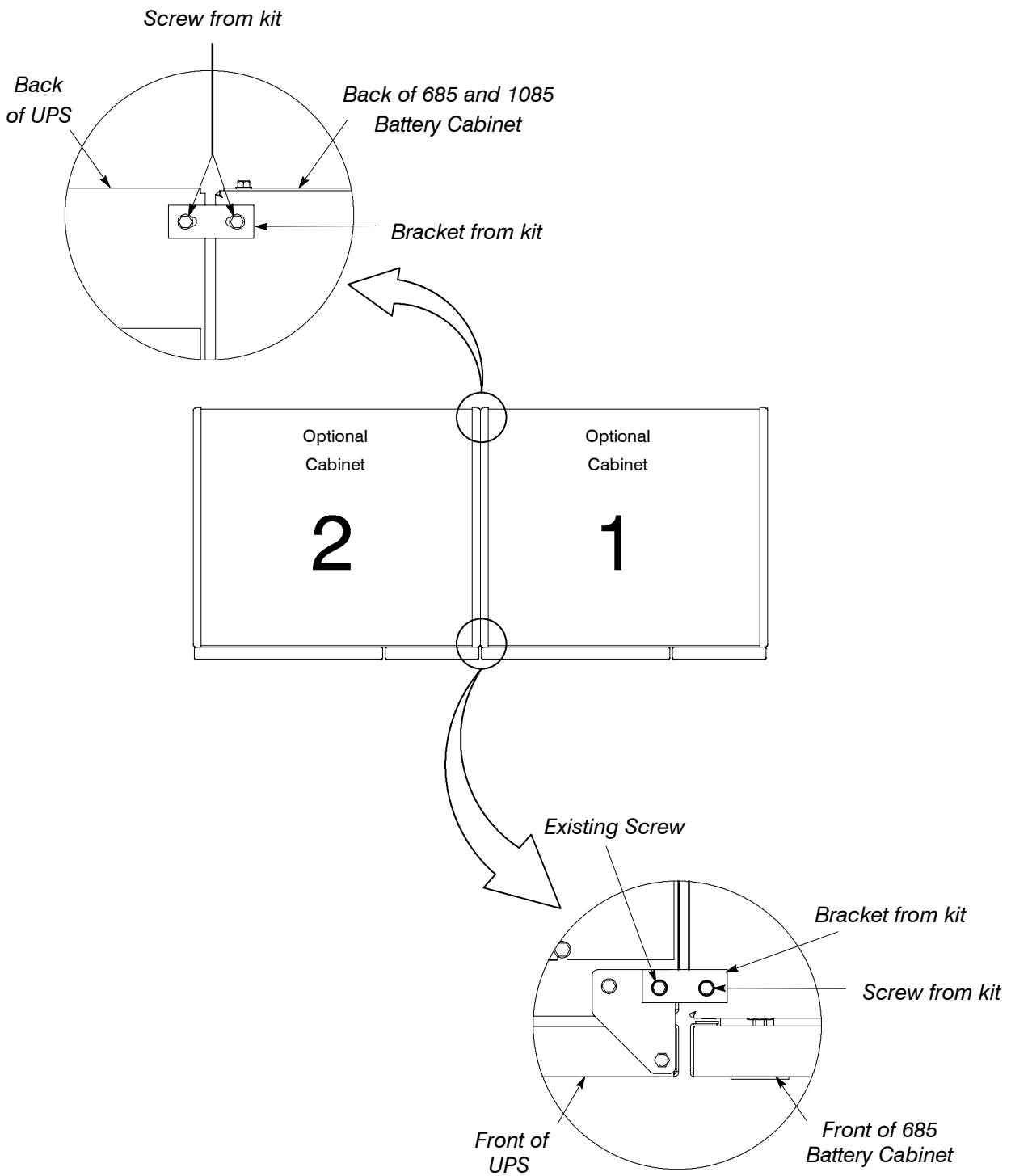

Figure 12. Joining Component Cabinets

Grounding Joined Cabinets

Open the door of each cabinet. Locate the grounding stud at the front/side of each frame. Remove the top nut, lock washer, and flat washer from each stud (if attached, see Figures 13 and 14).

Method A Grounding

1. Locate the grounding cable (part of the field kit, located in a small bag which is fastened to the UPS cabinet in the customer terminal area).
2. Mount the grounding cable as shown in Figure 13, attaching it to the frame of each cabinet using the hardware previously removed.
3. Secure each cabinet by lowering the front leveling feet.

Method B Grounding

1. Locate the grounding bar (part of the lug kit, located in a small bag which is fastened to the auxiliary cabinet safety shield inside the door).
2. Mount the grounding bar as shown in Figure 14, attaching it to the frame of each cabinet using the hardware previously removed.
3. Secure each cabinet by lowering the front leveling feet.
4. Repeat steps 1 through 3 for joining each additional cabinet.

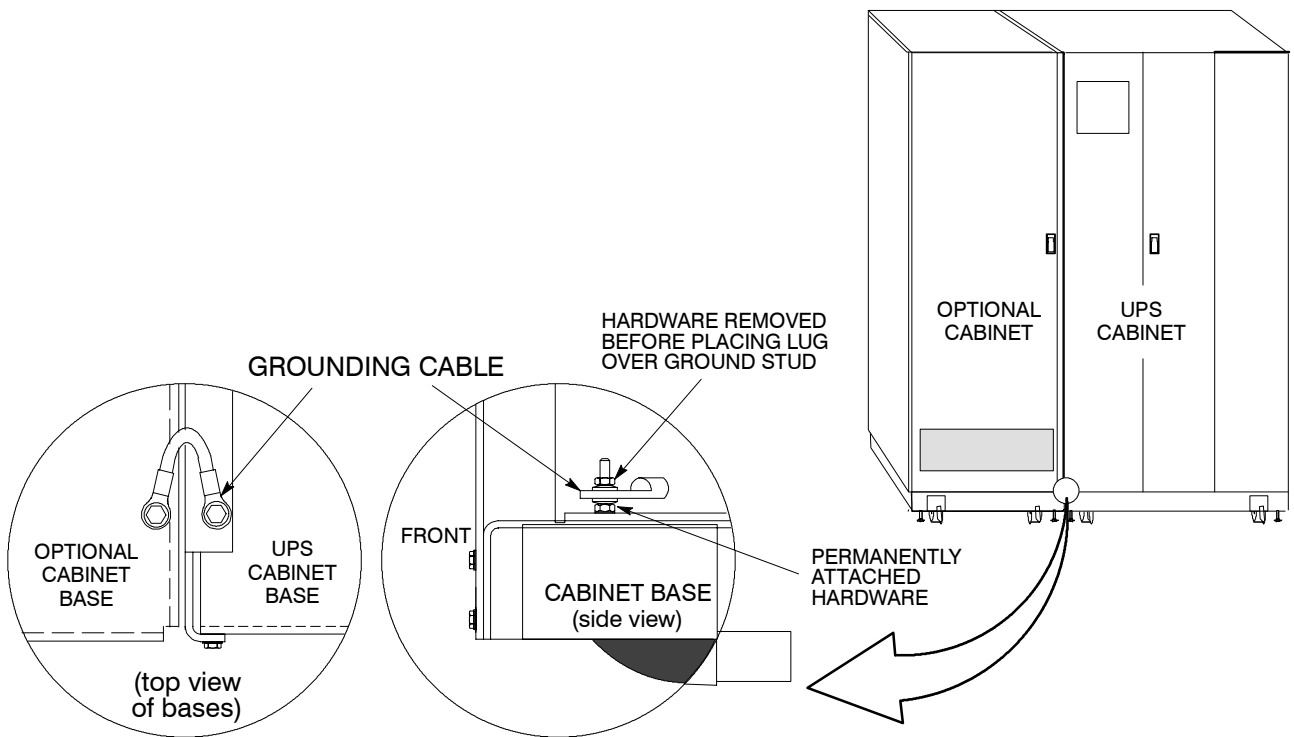

Figure 13. Cabinet-to-Cabinet Grounding – Method A

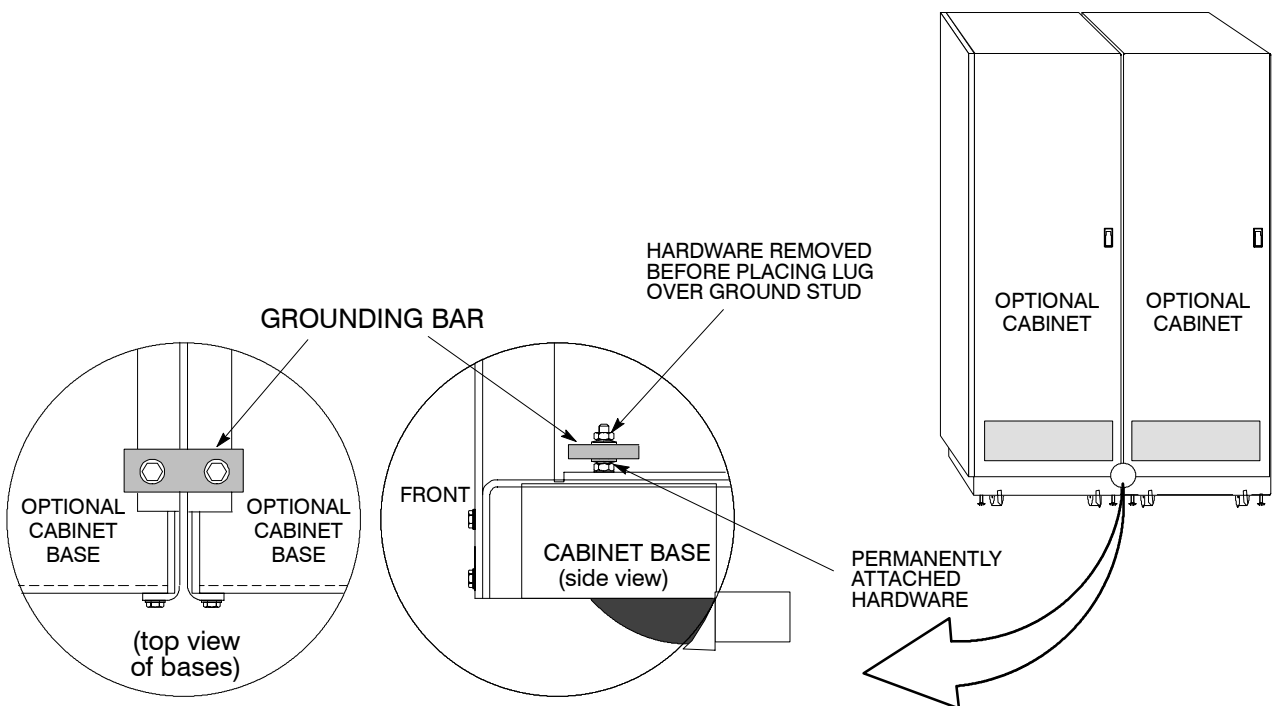

Figure 14. Cabinet-to-Cabinet Grounding – Method B

5

Installing Battery Cabinets

This chapter describes installing the UPS manufacturer's battery cabinets.

If you are installing battery cabinets and remote disconnects provided by Powerware Corporation, refer to the *Powerware 9315 Series 685 and 1085 Auxiliary Battery Cabinets Installation Manual*, 164200300, for instructions.

Two Models are Available

- Series 685 (685 mm wide cabinet)
- Series 1085 (1085 mm wide cabinet)

Important Safety Instructions

The installation of battery cabinets should be performed or supervised by personnel knowledgeable of batteries and their associated precautions. Keep unauthorized personnel away from battery cabinets.

Observe these precautions when working on or around battery cabinets:

- Remove watches, rings, or other metal objects.
- Use tools with insulated handles.
- Wear rubber gloves and boots.
- Do not lay tools or metal parts on top of batteries or battery cabinets.
- Disconnect the charging source prior to connecting or disconnecting terminals.
- Determine if the battery is inadvertently grounded. If it is, remove the source of the ground. Contact with any part of a grounded battery can result in electrical shock. The likelihood of such shock will be reduced if such grounds are removed during installation and maintenance.
- When replacing batteries, use the same number of sealed, lead-acid batteries.
- Proper disposal of batteries is required. Refer to your local codes for disposal requirements.

WARNING:

Do not dispose of battery or batteries in a fire. The battery may explode.

Do not open or mutilate the battery or batteries. Released electrolyte is harmful to the skin and eyes, and may be toxic.

A battery can cause electrical shock, burn from high short-circuit current, or fire. Take proper precautions when working with batteries.

ATTENTION:

Une batterie peut présenter un risque de choc électrique, de brûlure, ou d'incendie. Suivre les précautions qui s'imposent.

- Pour le remplacement, utiliser le même nombre et modèle des batteries.
- L'élimination des batteries est réglementée. Consulter les codes locaux à cet effet.

General Notes About Installing Battery Cabinets and Remote Disconnects

If you are installing battery cabinets not provided by Powerware Corporation, refer to the battery cabinet manufacturer's operating manual for instructions on battery cabinet installation and maintenance.

6

Installing an Input Transformer

Before installing the input transformer, be sure you have prepared the UPS according to the instructions in Chapter 3. The input transformer cabinet arrives as shown in Figure 15. See Drawing 164200292-6 in Appendix A for cabinet dimensions.

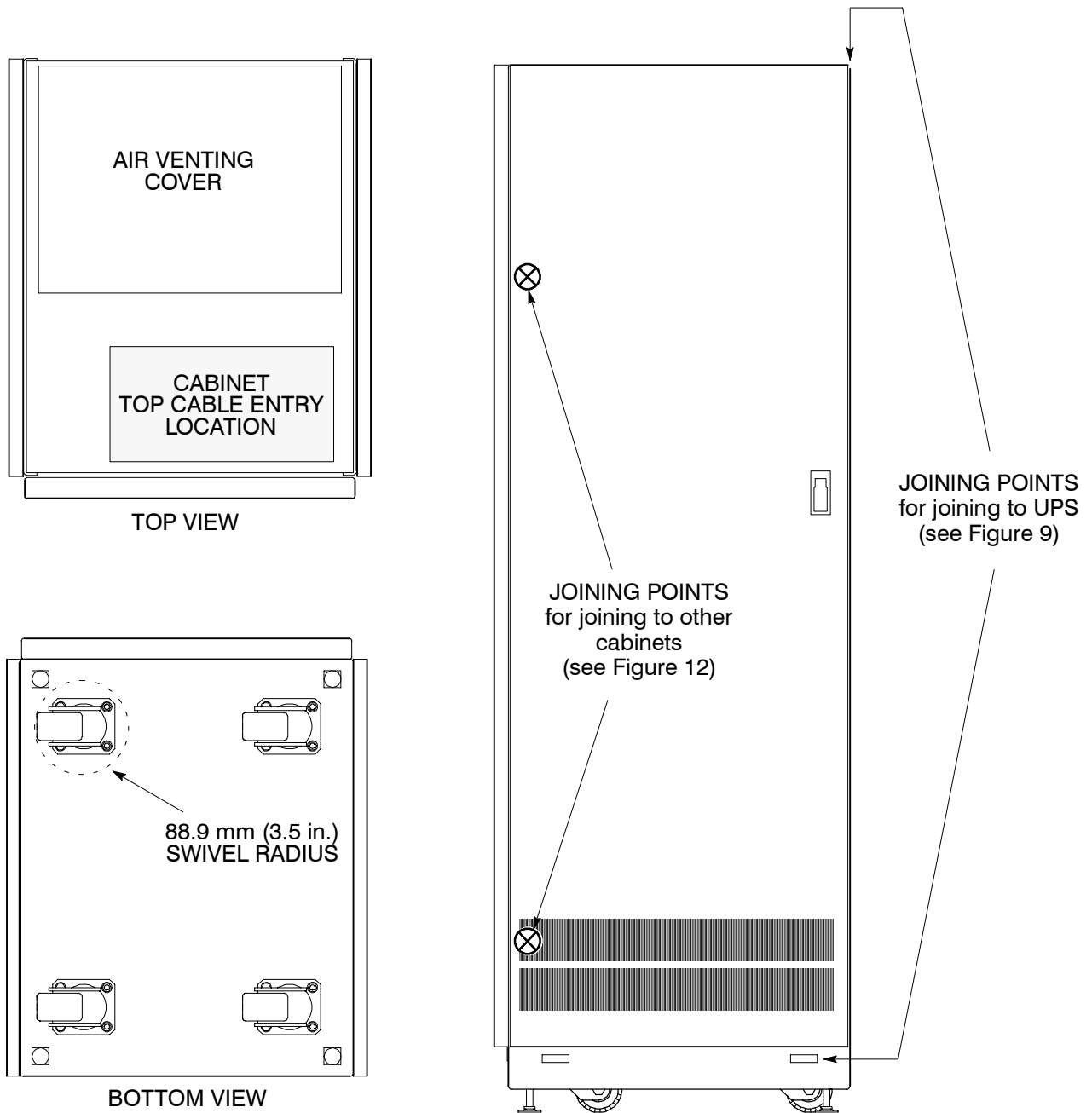

Figure 15. Input Transformer Cabinet

To prepare the input transformer cabinet for wiring to the UPS:

1. Roll the UPS into its final operating position and secure it with the leveling feet.
2. Roll the input transformer cabinet to the left of the UPS. Join the two cabinets using the appropriate method described in Chapter 4.
3. Open the door of the input transformer cabinet (press the top of the door latch, twist the latch lever clockwise 90°, and pull the door outward).
4. Remove the top and bottom deadfronts. Set the deadfronts and screws aside for remounting later.
5. Secure the transformer cabinet to the UPS cabinet. (Refer to procedure “Method A – Joining an Optional Cabinet to the UPS” in Chapter 4.)
6. Attach a ground bus between the UPS and transformer cabinet frames. (Refer to procedure “Grounding Joined Cabinets” in Chapter 4.)
7. Secure the cabinet with the leveling feet.

To wire the input transformer cabinet to the UPS:

1. Cables for interconnecting the input transformer to the UPS are coiled and tie-wrapped in place inside the input transformer cabinet. Locate and uncoil the cables. The connections inside the transformer cabinet are already made. Each cable is marked with its designation point in the UPS cabinet.
2. Connect the cables according to input voltage as shown in Table A. Also, refer to Figure 16.

Table A. Input Transformer to UPS Connection Points			
Connection Point in Transformer Cabinet (already made)			Connection point in UPS
<i>600VAC UPS</i>	<i>208 VAC UPS</i>	<i>400/480 VAC UPS</i>	
T1–X1	T1–H1	T1–X1	E1
T1–X2	T1–H2	T1–X2	E2
T1–X3	T1–H3	T1–X3	E3
T1–X1	T1–H1	n/a	E6
T1–X2	T1–H2	n/a	E7
T1–X3	T1–H3	n/a	E8

3. Mount the left side cover to the left side of the transformer cabinet:
 - a. Mount the hanger bracket to the top left side of the transformer cabinet.
 - b. Hang the left side cover on the hanger bracket and align with the front and rear of the transformer cabinet.
 - c. Secure the left side cover at the bottom with screws.
4. Replace the deadfront on the UPS cabinet. Close the UPS cabinet doors and the input transformer cabinet door.

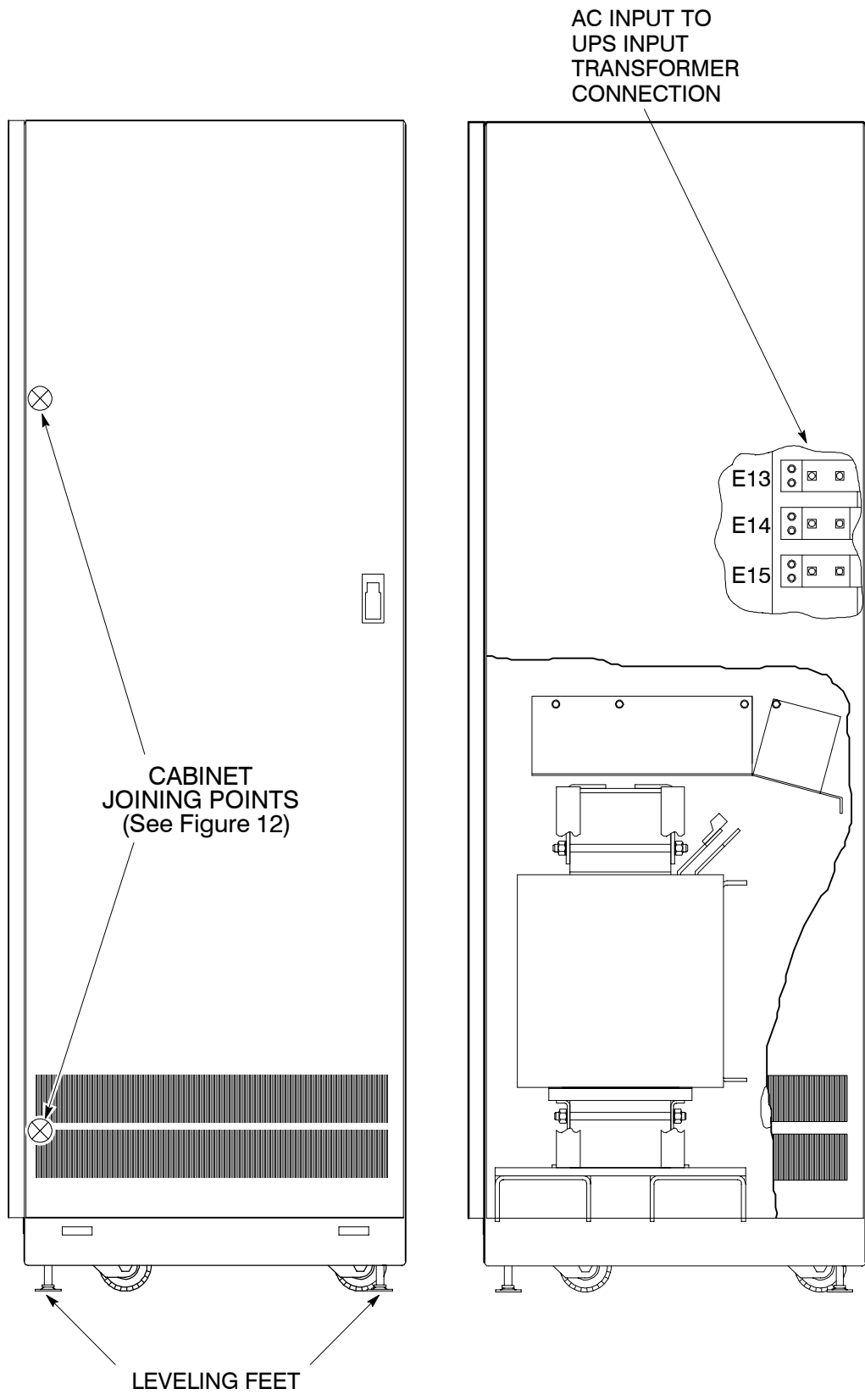

Figure 16. Installing an Input Transformer Cabinet

This Page Intentionally Left Blank.

7

Installing a Power Distribution Module

The Power Distribution Module (PDM) cabinet contains one or two interface panels, each containing 42 poles for breaker switches you can assign to meet the needs of your facility. Each panel is controlled by one 225 amp feeder breaker. The PDM cabinet arrives as shown in Figure 17 and Drawing 164200253-7 in Appendix A. Before installing the PDM, be sure you have prepared the UPS according to the instructions in Chapter 3. Refer to Powerware Power Distribution Module Installation and Operation Manual 164201061 for PDM installation and operation.

NOTE: This option requires an UPS with a 208 VAC output.

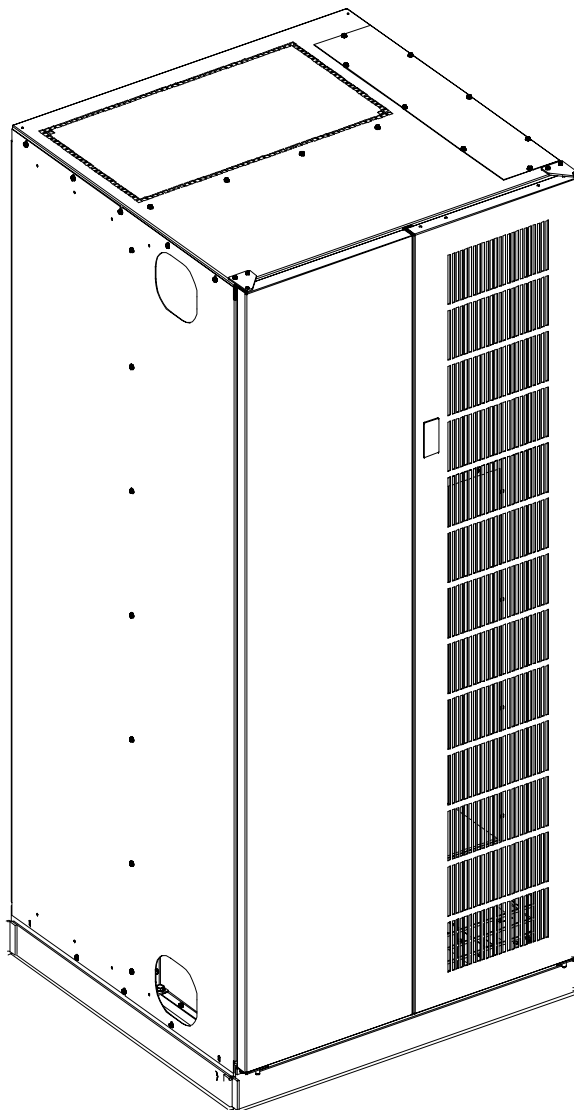

Figure 17. Typical PDM Cabinet

This Page Intentionally Left Blank.

8

Installing a Remote EPO Control

The Remote EPO control arrives as shown in Figure 18. See Drawing 164200292–9 in Appendix A for enclosure dimensions, side views, and knockout patterns.

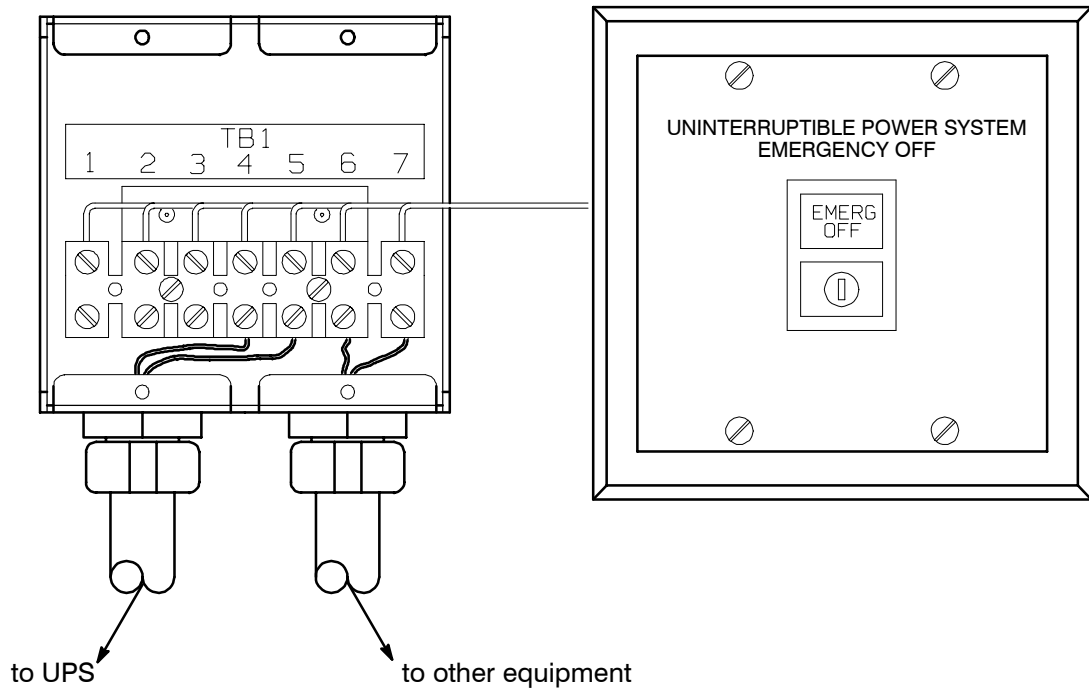

Figure 18. Remote EPO Control

To install a Remote EPO control:

1. Securely mount the Remote EPO station. Recommended locations include operator's consoles or exit doors.
2. Install wiring from the Remote EPO station using ½-in. conduit through the cable entry panels in either the top or bottom of the UPS.
3. Connect the Remote EPO wiring as shown in Tables B and C:

Table B. Remote EPO Wire Terminations		
From Remote EPO Station(s)	To Communications Panel in UPS	Remarks
TB1–4	TB2–1	Twisted wires (2) 14–18 gauge
TB1–5	TB2–2	

Table C. Remote EPO

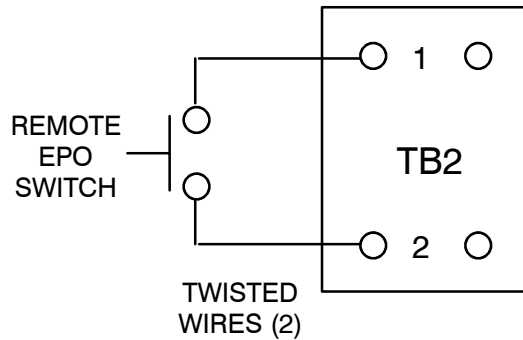

Remote EPO switch rating is 24 VDC.
1 Amp minimum if supplied by user.

NOTE: This switch must be a dedicated switch not tied into any other circuits.

4. If you are installing multiple Remote EPO stations, wire additional stations in parallel with the first Remote EPO.
5. If required, install 1/2-in. conduit and wiring from the Remote EPO station to trip circuitry of upstream protective devices. A normally open contact is provided, as shown in Table C. Remote EPO switch wiring must be in accordance with UL Class II requirements.
6. Secure the UPS by reversing all steps taken to prepare it for Remote EPO installation.

9 *Installing a Remote Battery Disconnect*

The remote battery disconnect is crated separately for shipping. The enclosure is designed to be wall-mounted on a surface that can support the weight and bolt pattern. You can install a remote battery disconnect anywhere between the remote DC supply and the UPS, according to national and local codes. Figure 19 shows the remote battery disconnect enclosure.

Refer to Chapter 5 of the *Powerware 9315 Series 685 and 1085 Auxiliary Battery Cabinets Installation Manual*, 164200300, for detailed instructions on installing a remote battery disconnect.

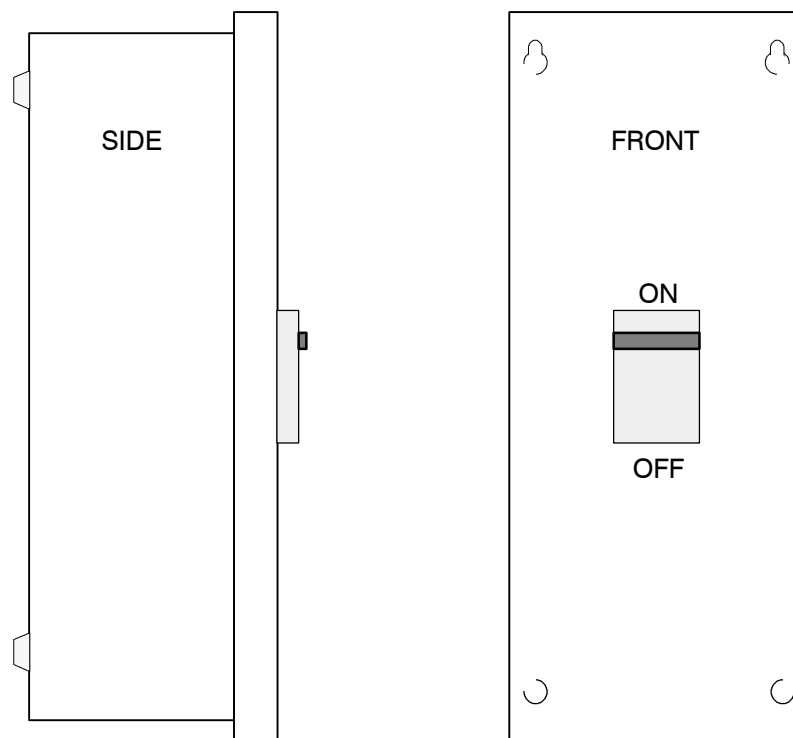

Figure 19. Remote Battery Disconnect Enclosure

This Page Intentionally Left Blank.

10

Installing a Remote Monitor Panel

As an option, you can install Remote Monitor Panels (RMPs) to monitor the operation of the UPS system from virtually any location within your facility, up to 500 feet from the UPS. You can flush-mount or surface-mount an RMP on a desktop or on a wall, wherever you have a serial interface line. A maximum of two monitoring accessories (RMPs, RIMs, or SCMs) can be installed. See Table D for the number of accessories permitted. Figure 20 shows an RMP. Drawing 164200292–10 in Appendix A shows the enclosure dimensions and knockout patterns.

Table D. Optional Monitoring Accessories		
Number and Type of Accessories Permitted		
Remote Monitor Panel	Relay Interface Panel	Supervisory Contact Module
2	—	—
—	2	—
—	—	2
1	1	—
1	—	1
—	1	1

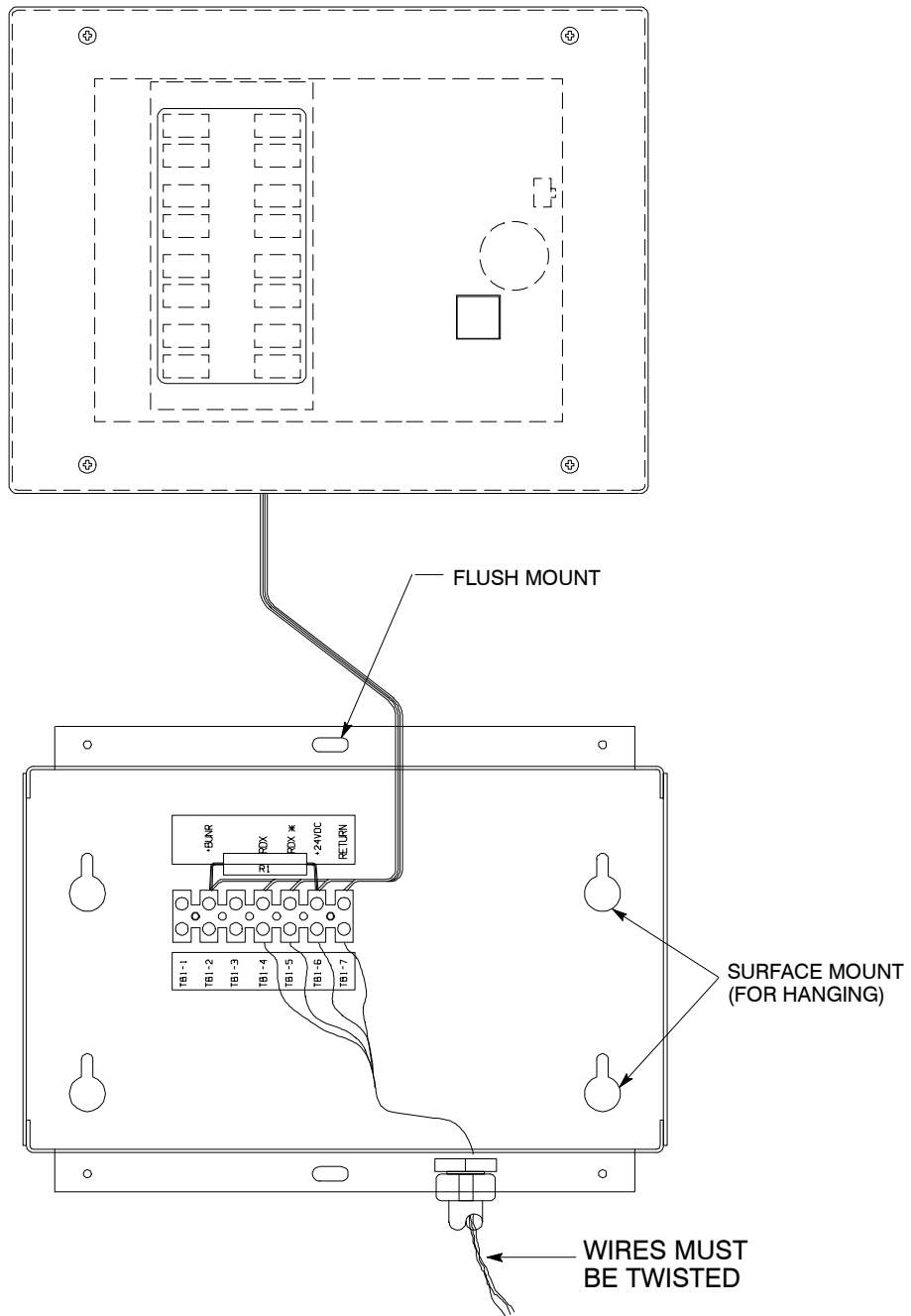

Figure 20. Remote Monitor Panel (RMP)

Before installing an RMP, be sure you have prepared the UPS according to the instructions in Chapter 3.

Powerware 9315 (100 kVA-160 kVA) Installation
164200292 REV. E 041500

To install an RMP:

1. Securely mount the RMP(s).
2. Install wiring from the RMP using 1/2-in. conduit through the cable entry panels in either the top or bottom of the UPS cabinet.

The top entry connection requires installation of 1/2-in. flexible conduit within the UPS. Bottom entry connection requires no additional routing of conduit within the UPS.

3. In the spare parts kit, locate the RMP adapter cable assembly (see Figure 21). Mate the DE-9 connector on the back of the terminal block into the DE-9 connector on the Communications Panel of the UPS (see Figure 22). Use two screws from the spare parts kit to secure the terminal block bracket to the Communications Panel.

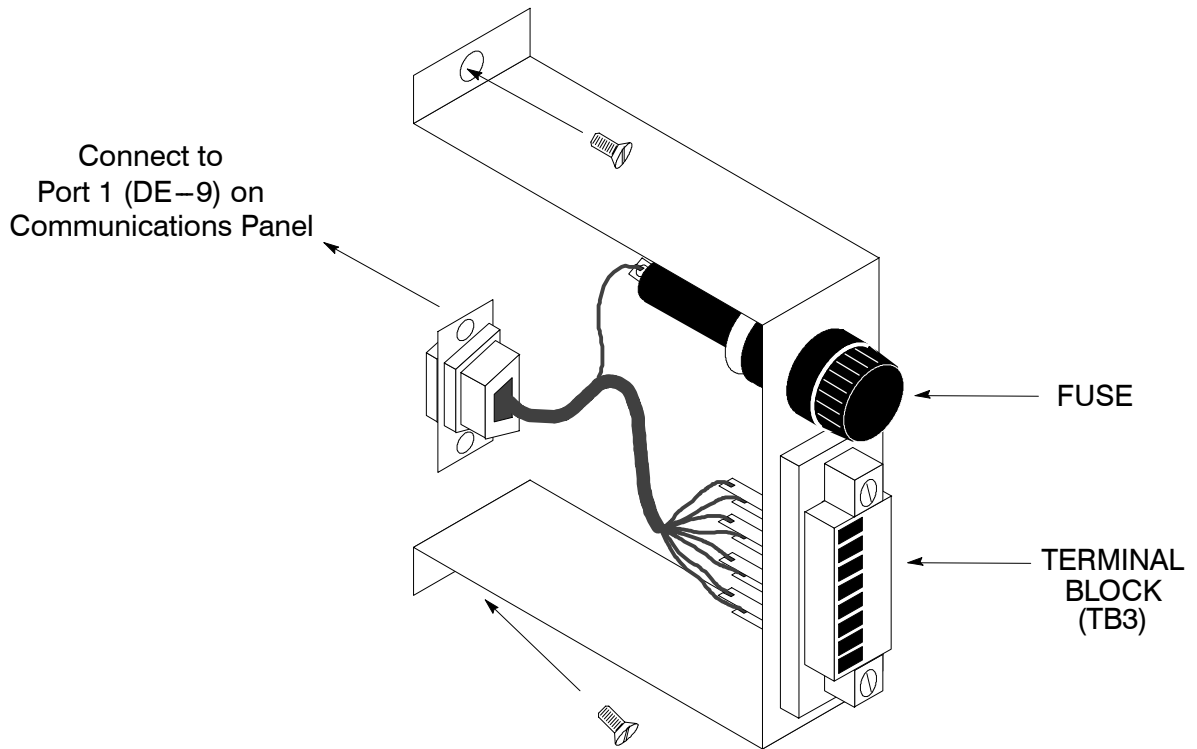

Figure 21. Terminal Block Bracket

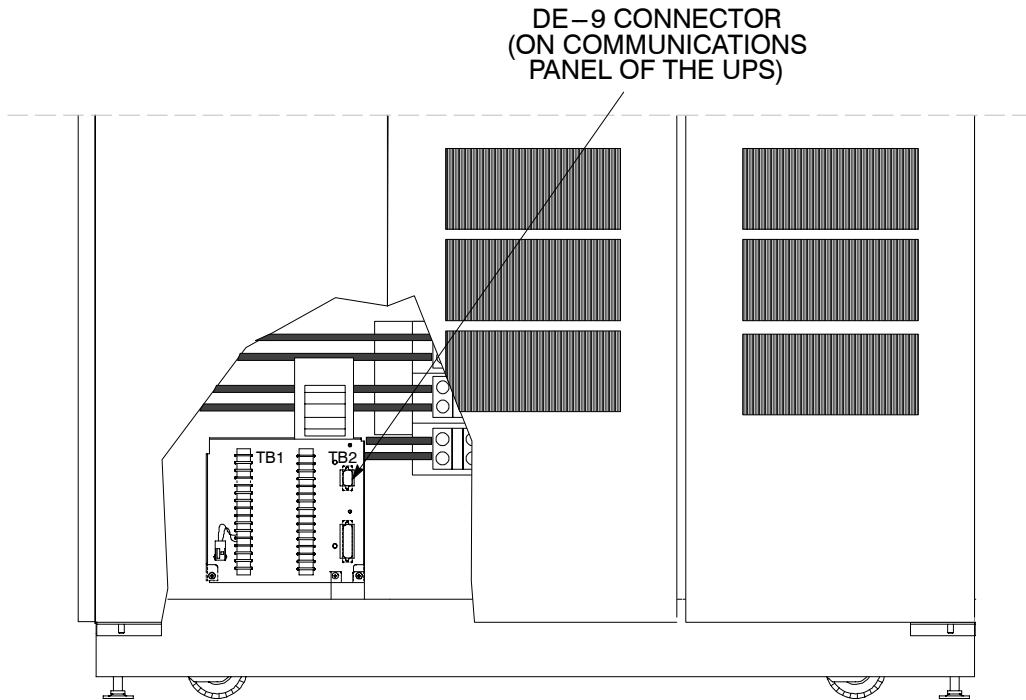

Figure 22. Wiring an RMP to the UPS

4. Connect RMP wiring to the terminal block using terminations shown in Table E.

Table E. RMP Wire Terminations		
<i>From RMP A</i>	<i>To UPS</i>	<i>Remarks</i>
TB1-4	TB3-1	TWISTED WIRES (4) 1-2 TURNS PER 3 INCHES
TB1-5	TB3-2	
TB1-6	TB3-3	
TB1-7	TB3-4	
<i>From RMP B (if used)</i>	<i>To UPS</i>	<i>Remarks</i>
TB1-4	TB3-5	TWISTED WIRES (4) 1-2 TURNS PER 3 INCHES
TB1-5	TB3-6	
TB1-6	TB3-7	
TB1-7	TB3-8	

5. To check the operation of the RMP, ensure that the UPS is supplying the load via inverter or bypass. If the indicators on the RMP show the appropriate status, then it is operating correctly.

If the communications link between the UPS and the RMP is not present, the RMP will self-test (all indicators flash and the horn beeps at one-second intervals). If this occurs, check all harness connectors and the fuse for proper seating. If all connections are secure but the RMP continues to self-test, replace the fuse with the spare included in the hardware kit. If this does not correct the problem, contact your local field service office for verification that the RMP is working correctly.

6. To test the indicator lamps, press the horn silence button and hold it for 3 seconds. All lamps should light, and the horn will sound continuously until you release the button.
7. Repeat steps 1, 2, and 4 through 6 for each RMP you are installing.
8. If you are installing an RIM or SCM in addition to an RMP, proceed to Chapter 11 or 12, respectively; otherwise, secure the UPS cabinet by reversing the steps contained in procedure "To Prepare the UPS for Wiring to an RMP, RIM, SCM, or Remote EPO" of Chapter 3.

This Page Intentionally Left Blank.

11

Installing a Relay Interface Module

The optional Relay Interface Module (RIM) uses relay contact closures to indicate the operating status and alarm condition of the UPS system. The module uses an RS422 serial interface line and may support up to eight critical loads. A maximum of two monitoring accessories (RMPs, RIMs, or SCMs) can be installed. Refer to Chapter 10, Table D for the number of accessories permitted. Figure 23 shows the RIM with its four 15-pin connectors labeled J1 through J4. Drawing 164200292–11 in Appendix A outlines the enclosure dimensions.

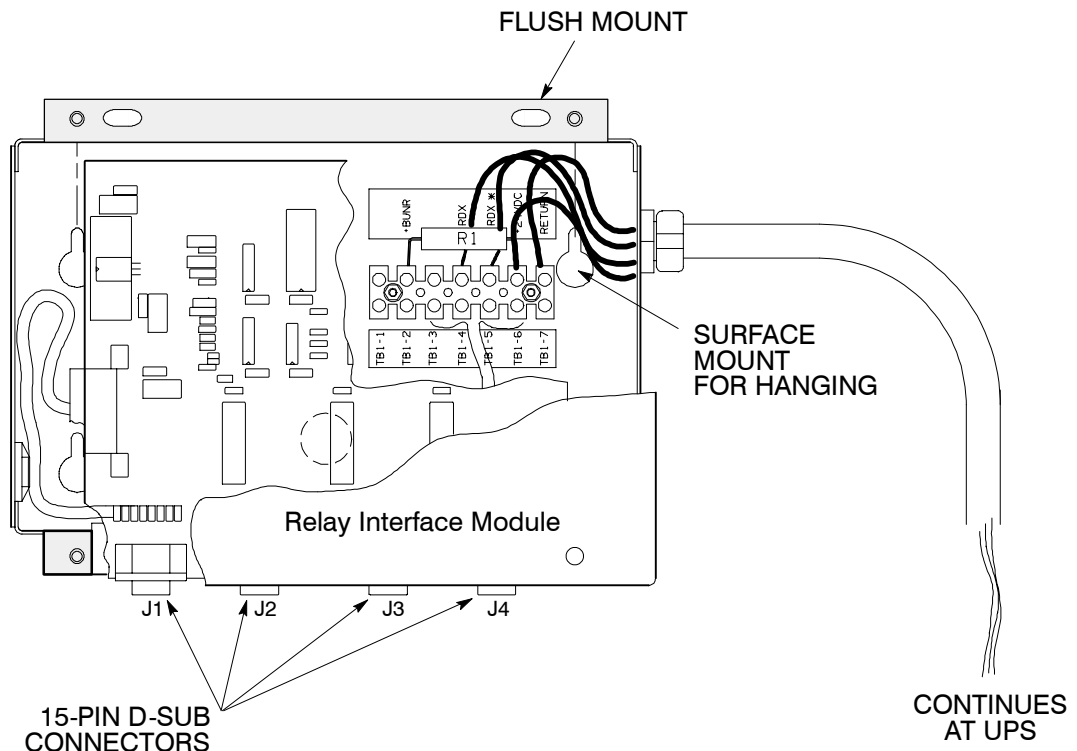

Figure 23. Relay Interface Module

To install an RIM:

1. Securely mount the RIM.
2. Install wiring from the RIM using 1/2-in. conduit through the 7/8-in. knockout in either the top or bottom of the UPS cabinet.

The top entry connection requires installation of 1/2-in. flexible conduit within the UPS. Bottom entry connection requires no additional routing of conduit within the UPS.

3. If not already installed, locate the RMP adapter cable assembly (see Figure 24) in the spare parts kit. Mate the DE–9 connector on the back of the terminal block into the DE–9 connector on the Communications Panel of the UPS (see Figure 25). Use two screws from the spare parts kit to secure the terminal block bracket to the Communications Panel.

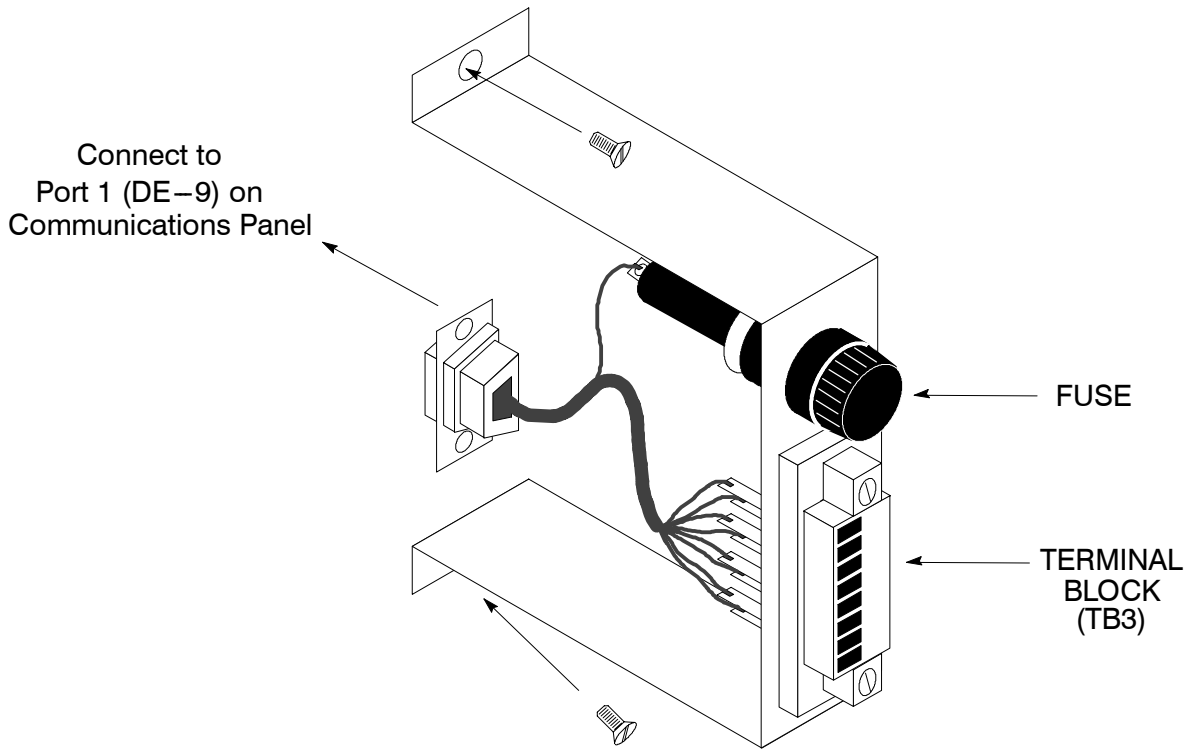

Figure 24. Terminal Block Bracket

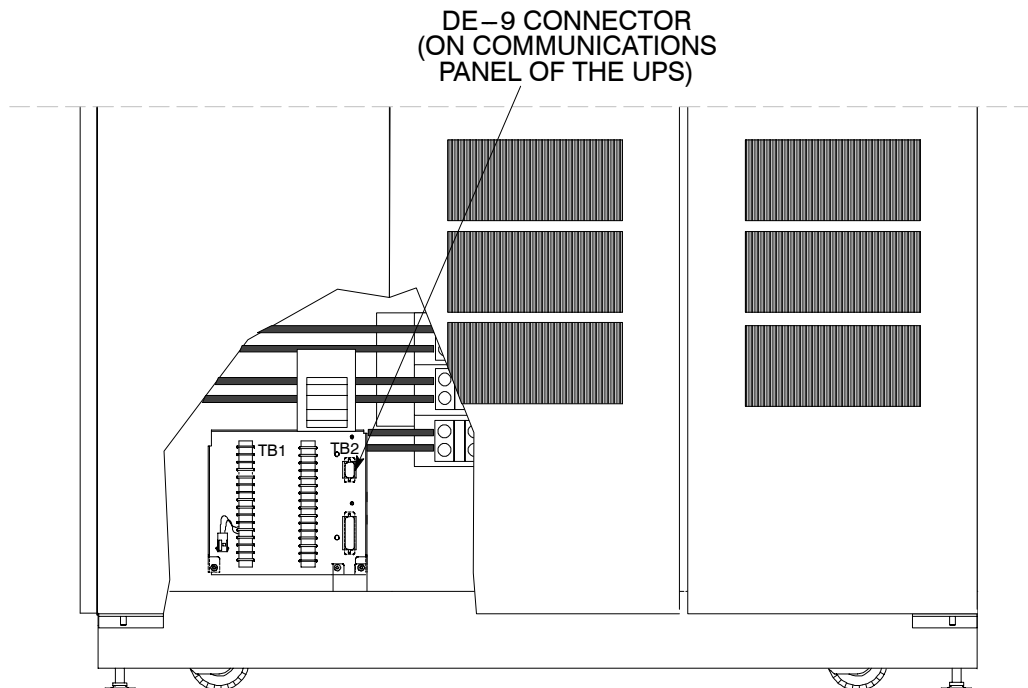

Figure 25. Wiring an RIM to the UPS

4. Connect RIM wiring to the terminal block using the terminations shown in Table F.
5. Contact your local field service office for verification and testing of the RIM and its connections prior to making connections with J1–J4.

You can order interface cables separately for connecting to the 15-Pin D-Sub Connectors.
6. Repeat steps 1 through 5 for each RIM you are installing.
7. If you are installing an RMP or SCM in addition to an RIM, proceed to Chapter 10 or 12, respectively; otherwise, secure the UPS cabinet by reversing the steps contained in procedure “To Prepare the UPS for Wiring to an RMP, RIM, SCM, or Remote EPO” of Chapter 3.

Table F. RIM Wire Terminations		
<i>From RIM A</i>	<i>To UPS</i>	<i>Remarks</i>
TB1–4	TB3–1	TWISTED WIRES (4) 1–2 TURNS PER 3 INCHES
TB1–5	TB3–2	
TB1–6	TB3–3	
TB1–7	TB3–4	
<i>From RIM B (if used)</i>	<i>To UPS</i>	<i>Remarks</i>
TB1–4	TB3–5	TWISTED WIRES (4) 1–2 TURNS PER 3 INCHES
TB1–5	TB3–6	
TB1–6	TB3–7	
TB1–7	TB3–8	

This Page Intentionally Left Blank.

12

Installing a Supervisory Contact

The optional Supervisory Contact Module (SCM) as shown in Figure 26 provides contacts for monitoring UPS status. A maximum of two monitoring accessories (RMPs, RIMs, or SCMs) can be installed. Refer to Chapter 10, Table D for the number of accessories permitted. See Drawing 164200292–12 in Appendix A for enclosure dimensions, side views, and knockout patterns.

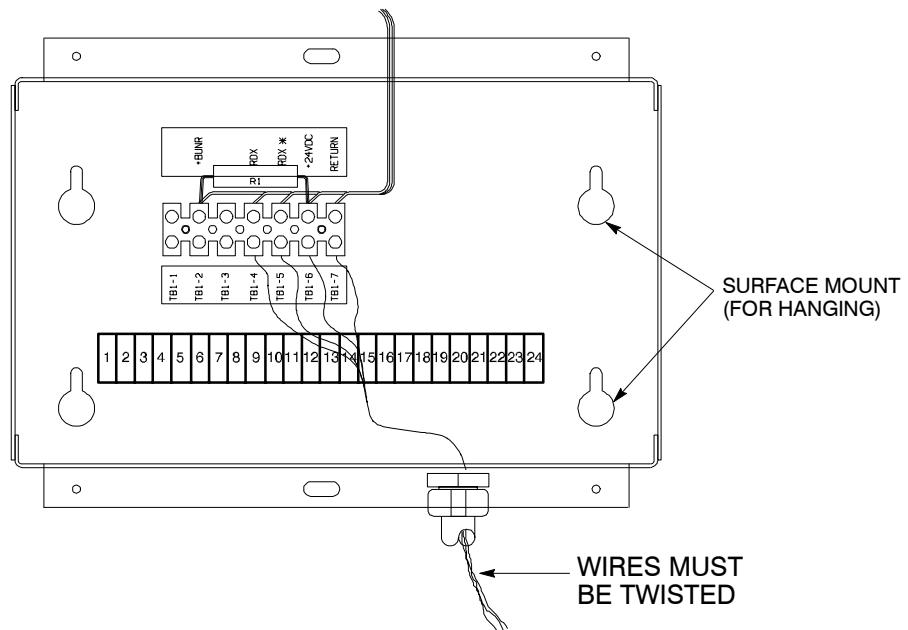

Figure 26. Supervisory Contact Module

To install a Supervisory Contact Module:

1. Securely mount the SCM.
2. Install wiring from the SCM using $\frac{1}{2}$ -in. conduit through the $\frac{7}{8}$ -in. knockout in either the top or bottom of the UPS cabinet.

The top entry connection requires installation of $\frac{1}{2}$ -in. flexible conduit within the UPS. Bottom entry connection requires no additional routing of conduit within the UPS.

3. If not already installed, locate the RMP adapter cable assembly (see Figure 27) in the spare parts kit. Mate the DE–9 connector on the back of the terminal block into the DE–9 connector on the Communications Panel of the UPS (see Figure 28). Use two screws from the spare parts kit to secure the terminal block bracket to the Communications Panel.

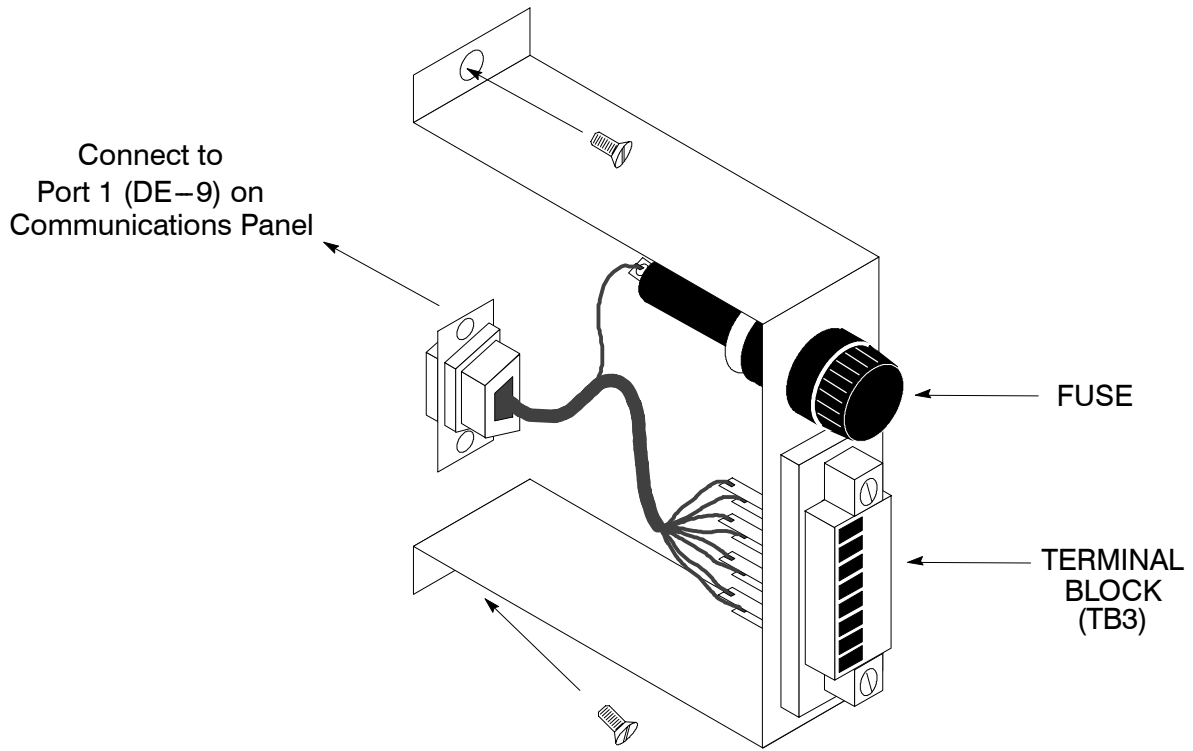

Figure 27. Terminal Block Bracket

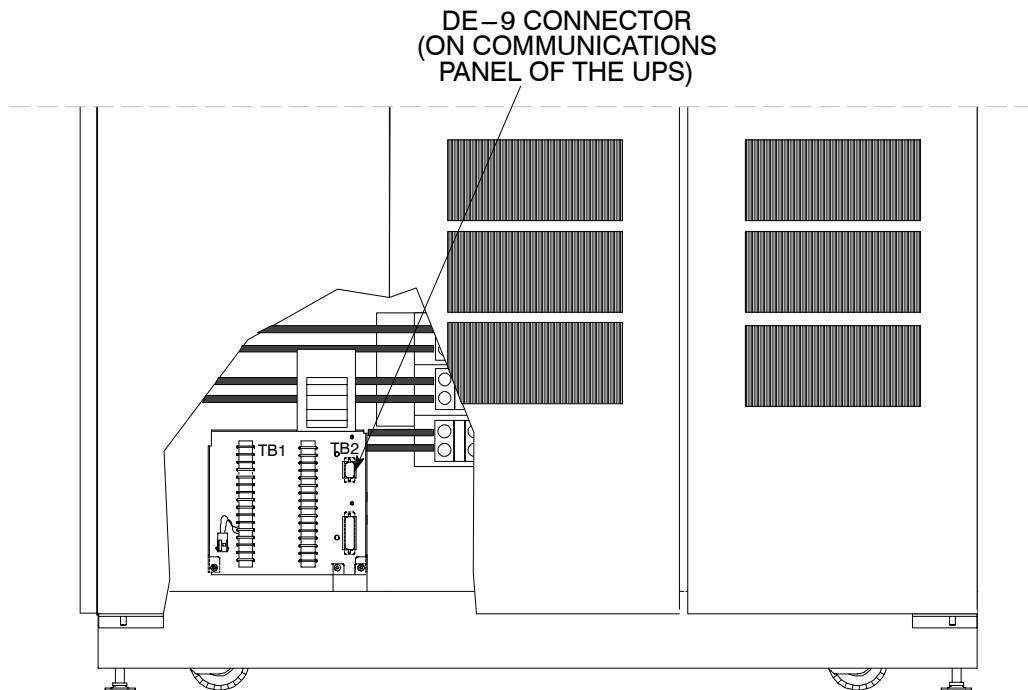
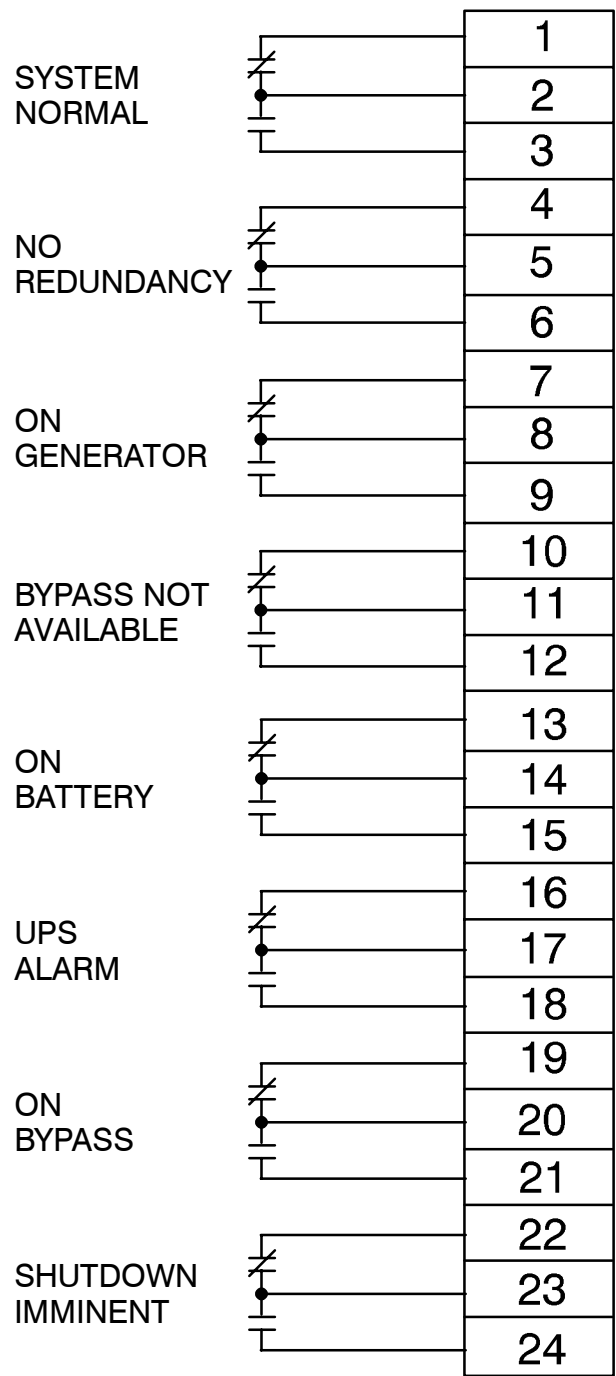

Figure 28. Wiring an SCM to the UPS

4. Connect the SCM wiring to the terminal block using the terminations shown in Table G.
5. Contact your local field service office for verification and testing of the SCM and its connections prior to making connections to terminal strip shown in Figure 29.
6. Repeat steps 1 through 5 for each SCM you are installing.
7. If you are installing an RMP or RIM in addition to an SCM, proceed to Chapter 10 or 11, respectively; otherwise, secure the UPS cabinet by reversing the steps contained in procedure “To Prepare the UPS for Wiring to an RMP, RIM, SCM, or Remote EPO” of Chapter 3.

Table G. Supervisory Contact Module Wire Terminations		
<i>From SCM A</i>	<i>To UPS</i>	<i>Remarks</i>
TB1-4	TB3-1	TWISTED WIRES (4) 1-2 TURNS PER 3 INCHES
TB1-5	TB3-2	
TB1-6	TB3-3	
TB1-7	TB3-4	
<i>From SCM B (if used)</i>	<i>To UPS</i>	<i>Remarks</i>
TB1-4	TB3-5	TWISTED WIRES (4) 1-2 TURNS PER 3 INCHES
TB1-5	TB3-6	
TB1-6	TB3-7	
TB1-7	TB3-8	



Note: Supervisory contacts are rated at 2.0 amps at 28 Vdc or 120 Vac and 0.15 amp at 115 Vdc.

Supervisory contacts require external power supply. Internal 24 Vdc is not capable of supplying contact current.

Figure 29. Supervisory Contact Module TB2

Appendix A – Customer Information

The information in this appendix will help you plan for and install your UPS system. This appendix contains the following drawings:

- 164200253–1 Installation Notes
- 164200253–2 Typical UPS System
- 164200253–3 Oneline Drawings of UPS System
- 164200253–4 Location of UPS Power Terminals
- 164200253–5 UPS Cabinet
- 164200253–6 Input Transformer Cabinet
- 164200253–7 Power Distribution Module
- 164200253–8 Maintenance Bypass Module
- 164200253–9 Remote Emergency Power Off
- 164200253–10 Remote Monitor Panel
- 164200253–11 Relay Interface Module
- 164200253–12 Supervisory Contact Module

Table H. INPUT Ratings & External Wiring Requirements for Powerware 9315 150 & 160

Ratings		Units	Input Rating 60 Hz											
Basic unit rating at 0.8 lagging PF load		KVA	160				150				130			
		KW	128				120				104			
		INPUT VOLTAGE	208	220	480	600	208	220	480	600	208	220	480	600
A C I N P U T	AC Input to UPS Rectifier or Input Transformer (.95min.PF) 3 \emptyset , 1 gnd Minimum conductor size (number per \emptyset) A	Amps with Filter	480	454	200	167	480	454	200	167	400	379	174	139
		Amps without Filter	565	534	240	196	565	534	240	196	471	445	200	160
		AWG or kcmil(ea) with Filter	350 (2)	300 (2)	250	4/0	350 (2)	300 (2)	250	4/0	250 (2)	250 (2)	4/0	2/0
		AWG or kcmil(ea) without Filter	500 (2)	400 (2)	350	250	500 (2)	400 (2)	350	3/0	350 (2)	300 (2)	250	3/0
B A C I N P U T	AC Input to Bypass Full Load Current 3 \emptyset , 1 gnd Minimum conductor size (number per \emptyset) B	Amps	444	420	192	154	400	394	180	144	361	341	156	125
		AWG or kcmil(ea)	300 (2)	300 (2)	250	3/0	250 (2)	250 (2)	4/0	3/0	4/0 (2)	4/0 (2)	3/0	2/0
C D C I N P U T	DC Input from Battery to UPS (1) positive, (1) negative C	VDC	480	480	480	480	480	480	480	480	480	480	480	480
		Amps @ (1.8V/cell)	320	320	320	320	300	300	300	300	260	260	260	260

Read and understand the following notes while planning your installation:

1. Refer to national and local electrical codes for acceptable external wiring practices.
2. Material and labor for external wiring requirements are to be provided by designated personnel.
3. For external wiring requirements, including the minimum AWG size of external wiring, see the appropriate column in Table H. The power wiring for this equipment is rated at 75°C. If wire is run in an ambient temperature greater than 30°C, higher temperature and/or larger size wire may be necessary.

NOTE: Callout letter **A**, **B**, **C**, and **D** map to drawing #164200292-3

DESCRIPTION:	INSTALLATION NOTES		
DRAWING NO:	164200292-1	SHEET:	1 of 14
REVISION:	E	DATE:	041500

**Table H. INPUT Ratings & External Wiring Requirements for Powerware 9315
150 & 160**

Ratings		Units	Input Rating 60 Hz								
Basic unit rating at 0.8 lagging PF load		KVA	125				100				
		KW	100				80				
		INPUT VOLTAGE	208	220	480	208	600	208	220	480	600
A C I N P U T	AC Input to UPS Rectifier or Input Transformer (.95min.PF) 3 \emptyset , 1 gnd <i>Minimum conductor size (number per \emptyset)</i>	Amps with Filter	400	379	174	400	139	320	303	139	111
		Amps without Filter	471	445	200	471	160	377	356	160	131
		AWG or kcmil(ea) with Filter	250 (2)	250 (2)	4/0	250 (2)	2/0	3/0 (2)	500	2/0	1/0
		AWG or kcmil(ea) without Filter	350 (2)	300 (2)	250	350 (2)	1/0	250 (2)	4/0 (2)	3/0	2/0
A C I N P U T	AC Input to Bypass Full Load Current 3 \emptyset , 1 gnd <i>Minimum conductor size (number per \emptyset)</i>	Amps	347	328	150	347	120	278	262	120	96
		AWG or kcmil(ea)	4/0 (2)	4/0 (2)	3/0	4/0 (2)	1/0	500	400	1/0	1/0
D C I N P U T	DC Input from Battery to UPS (1) positive, (1) negative	VDC	480	480	480	480	480	480	480	480	480
		Amps @ (1.8V/cell)	250	250	250	250	250	200	200	200	200

Read and understand the following notes while planning your installation:

1. Refer to national and local electrical codes for acceptable external wiring practices.
2. Material and labor for external wiring requirements are to be provided by designated personnel.
3. For external wiring requirements, including the minimum AWG size of external wiring, see the appropriate column in Table H. The power wiring for this equipment is rated at 75°C. If wire is run in an ambient temperature greater than 30°C, higher temperature and/or larger size wire may be necessary.

NOTE: Callout letter **A**, **B**, **C**, and **D**
map to drawing #164200292-3

DESCRIPTION:	INSTALLATION NOTES	
DRAWING NO:	164200292-1	SHEET: 2 of 14
REVISION: E	DATE:	041500

Table I. OUTPUT Ratings & External Wiring Requirements for Powerware 9315 150 & 160

Ratings		Units	Output Rating 60 Hz								
Basic unit rating at 0.8 lagging PF load		KVA	160			150			130		
		KW	128			120			104		
		OUTPUT VOLTS	480	208	600	480	208	600	480	208	600
A C O U T P U T	AC Output to Critical Load Full Load Current 3 \emptyset , (1) Neutral, (1) gnd	Amps	192	444	154	180	416	144	156	361	125
	Minimum conductor size (number per \emptyset) D	AWG or kcmil(ea)	250	300 (2)	3/0	4/0	250 (2)	3/0	3/0	4/0 (2)	2/0

Read and understand the following notes while planning your installation:

1. Refer to national and local electrical codes for acceptable external wiring practices.
2. Material and labor for external wiring requirements are to be provided by designated personnel.
3. For external wiring requirements, including the minimum AWG size of external wiring, see the appropriate column in Table I. The power wiring for this equipment is rated at 75°C. If wire is run in an ambient temperature greater than 30°C, higher temperature and/or larger size wire may be necessary.

NOTE: Callout letter **A**, **B**, **C**, and **D** map to drawing #164200292-3

DESCRIPTION:	INSTALLATION NOTES	
DRAWING NO:	164200292-1	SHEET: 3 of 14
REVISION:	E	DATE: 041500

Table I. OUTPUT Ratings & External Wiring Requirements for Powerware 9315 150 & 160

Ratings		Units	Output Rating 60 Hz					
Basic unit rating at 0.8 lagging PF load		KVA	125			100		
		KW	100			80		
		OUTPUT VOLTS	480	208	600	480	208	600
A C O U T P U T	AC Output to Critical Load Full Load Current 3 \emptyset , (1) Neutral, (1) gnd	Amps	150	347	120	120	278	96
	Minimum conductor size (number per \emptyset) D	AWG or kcmil(ea)	3/0	4/0 (2)	1/0	1/0	500	1/0

Read and understand the following notes while planning your installation:

1. Refer to national and local electrical codes for acceptable external wiring practices.
2. Material and labor for external wiring requirements are to be provided by designated personnel.
3. For external wiring requirements, including the minimum AWG size of external wiring, see the appropriate column in Table I. The power wiring for this equipment is rated at 75°C. If wire is run in an ambient temperature greater than 30°C, higher temperature and/or larger size wire may be necessary.

NOTE: Callout letter **A**, **B**, **C**, and **D** map to drawing #164200292-3

DESCRIPTION:	INSTALLATION NOTES		
DRAWING NO:	164200292-1	SHEET:	4 of 14
REVISION:	E	DATE:	041500

Table J. Ratings & External Wiring Requirements for Powerware 9315 125, 130, 150, and 160 380/400/415 Volt Units

Ratings		Units	Rating 50/60 Hz					
Basic unit rating at 0.8 lagging PF load		Model	Plus 160			Plus 150		
		KVA KW	160 128	130 104	100 80	150 120	125 100	100 80
A C I N P U T	AC Input to UPS Rectifier or Input Transformer (.95min.PF) 3 Ø, (1) gnd A Minimum conductor size (number per Ø)	Amps with Input Filter	240	200	160	240	200	160
		Amps w/o input Filter	280	240	198	280	240	198
	AC Input to Bypass Full Load Current 3 Ø, (1) gnd B Minimum conductor size (number per Ø)	AWG or kcmil(ea) with Input Filter	350	250	3/0	350	250	3/0
		AWG or kcmil(ea) without Input Filter	500	350	250	500	350	250
D C I N P U T	DC Input from Battery to UPS (1) positive, (1) negative C Minimum conductor size (number per Ø)	Amps	231	188	146	217	182	146
		AWG or kcmil(ea)	350	250	3/0	300	4/0	3/0
A C O U T P U T	AC Output to Critical Load Full Load Current 3 Ø, (1) Neutral, (1) gnd D Minimum conductor size (number per Ø)	Amps	231	188	146	217	182	146
		AWG or kcmil(ea)	350	250	3/0	300	4/0	3/0

You should read and understand these notes while planning your installation:

1. Refer to national and local electrical codes for acceptable external wiring practices.
2. Material and labor for external wiring requirements are to be provided by designated personnel.
3. For external wiring requirements, including the minimum AWG size of external wiring, see the appropriate column in Table J. The power wiring for this equipment is rated at 75°C. If wire is run in an ambient temperature greater than 30°C, higher temperature and/or larger size wire may be necessary.

NOTE: Callout letter **A**, **B**, **C**, and **D** map to drawing #164200292-3
400V = 380/400/415 Volt

DESCRIPTION:	INSTALLATION NOTES	
DRAWING NO:	164200292-1	SHEET: 5 of 14
REVISION:	E	DATE: 041500

Table J. Ratings & External Wiring Requirements for Powerware 9315 125, 130, 150, and 160 380/400/415 Volt Units

Ratings		Units	Rating 50/60 Hz			
Basic unit rating at 0.8 lagging PF load		Model	Plus 130		Plus 125	
		KVA KW	130 104	100 80	125 100	100 80
A C I N P U T	AC Input to UPS Rectifier or Input Transformer (.95min.PF) 3 \emptyset , (1) gnd Ⓐ Minimum conductor size (number per \emptyset)	Amps with Input Filter	200	160	200	160
		Amps w/o input Filter	235	188	235	188
	AC Input to Bypass Full Load Current 3 \emptyset , (1) gnd Ⓑ Minimum conductor size (number per \emptyset)	AWG or kcmil(ea) with Input Filter	250	3/0	250	3/0
		AWG or kcmil(ea) without Input Filter	350	250	350	250
D C I N P U T	DC Input from Battery to UPS (1) positive, (1) negative Ⓒ Minimum conductor size (number per \emptyset)	Amps	188	146	182	146
		AWG or kcmil(ea)	250	3/0	4/0	3/0
A C O U T P U T	AC Output to Critical Load Full Load Current 3 \emptyset , (1) Neutral, (1) gnd Ⓓ Minimum conductor size (number per \emptyset)	Amps	188	146	182	146
		AWG or kcmil(ea)	250	3/0	4/0	3/0

You should read and understand these notes while planning your installation:

1. Refer to national and local electrical codes for acceptable external wiring practices.
2. Material and labor for external wiring requirements are to be provided by designated personnel.
3. For external wiring requirements, including the minimum AWG size of external wiring, see the appropriate column in Table J. The power wiring for this equipment is rated at 75°C. If wire is run in an ambient temperature greater than 30°C, higher temperature and/or larger size wire may be necessary.

NOTE: Callout letter Ⓐ, Ⓑ, Ⓒ, and Ⓓ map to drawing #164200292-3

400V=380/400/415 Volt

DESCRIPTION:	INSTALLATION NOTES	
DRAWING NO:	164200292-1	SHEET: 6 of 14
REVISION: E	DATE: 041500	

1. The output of the UPS is a separately derived source. Output neutral is bonded to equipment ground through the main bonding jumper. Refer to NEC Article 250 and local codes for proper grounding practices.
2. External overcurrent protection is not provided by this product, but is required by codes. Refer to Tables H through J for wiring requirements. If an output lockable disconnect is required, it is to be supplied by designated personnel.
3. When an input transformer is present, the rectifier and bypass inputs may both be supplied by the same source.
4. Non-linear loads can create neutral currents that are greater than 100%. This product can accommodate double-sized neutral terminations if needed.
5. Terminals E1 through E15 are UL and CSA rated at 90°C. A hex key tool is required to attach wires to terminals. Refer to Table K for power cable terminations. Drawing 164200292-4 shows the location of the power cable terminals inside the UPS cabinet.

Table K. Power Cable Terminations

<i>Terminal Function</i>	<i>Terminal</i>	<i>Function</i>	<i>Size of Pressure Termination</i>	<i>Tightening Torque N-M (lb-in)</i>	<i>Int Hex Size (In.)</i>
Internal Wiring to UPS Rectifier	E1	Phase 'A'	1 – #8–350 kcmil	38.1 (275)	5/16
	E2	Phase 'B'	1 – #8–350 kcmil	38.1 (275)	5/16
	E3	Phase 'C'	1 – #8–350 kcmil	38.1 (275)	5/16
AC Input to UPS Input Transformer (as applicable)	E13	Phase 'A'	2 – #2–600 kcmil	56.5 (500)	1/2
	E14	Phase 'B'	2 – #2–600 kcmil	56.5 (500)	1/2
	E15	Phase 'C'	2 – #2–600 kcmil	56.5 (500)	1/2
AC Input to Bypass	E6	Phase 'A'	1 – #6–350 kcmil	42.4 (375)	3/8
	E7	Phase 'B'	1 – #6–350 kcmil	42.4 (375)	3/8
	E8	Phase 'C'	1 – #6–350 kcmil	42.4 (375)	3/8
AC Output to Critical Load	E9	Phase 'A'	2 – #4–500 kcmil	42.4 (375)	3/8
	E10	Phase 'B'	2 – #4–500 kcmil	42.4 (375)	3/8
	E11	Phase 'C'	2 – #4–500 kcmil	42.4 (375)	3/8
	E12	Neutral/Gnd.	4 – #6–350 kcmil	42.4 (375)	3/8
DC Input from Battery to UPS	E4	Battery (+)	1 – #4–500 kcmil	42.4 (375)	3/8
	E5	Battery (-)	1 – #4–500 kcmil	42.4 (375)	3/8
Customer Ground	Ground	Ground	4 – #6–350 kcmil	42.4 (375)	3/8

<i>DESCRIPTION:</i> INSTALLATION NOTES	
<i>DRAWING NO:</i> 164200292-1	<i>SHEET:</i> 7 of 14
<i>REVISION:</i> C	<i>DATE:</i> 081596

1. In the UPS system, each battery cabinet, PDM cabinet, and the input transformer cabinet are crated separately for shipping and are bolted together on site.
2. Do not tilt cabinets more than $\pm 10^\circ$ during handling.
3. Dimensions are in millimeters (inches).
4. If perforated floor tiles are required for ventilation, you should place them in front of the UPS. Table L lists the ventilation requirements for full load operation:

Table L. Air Conditioning or Ventilation Requirements During Full Load Operation		
<i>Ratings</i>	<i>Input/Output Voltage</i>	Heat Rejection* BTU/hr \times 1000/hr (Kg-cal/hr)
Powerware 9315 125 and 130		
100 KVA	400/400	23.8 (5.99)
125 KVA	400/400	29.7 (7.49)
130 KVA	400/400	29.7 (7.49)
Powerware 9315 150 and 160		
100 KVA	480/208, 480/480	23.8 (5.99)
	208/208, 600/208, 400/400, 600/600, 220/208	27.0 (6.81)
125 KVA	480/208, 480/480	29.7 (7.48)
	208/208, 600/208, 400/400, 600/600, 220/208	33.8 (8.51)
130 KVA	480/208, 480/480	29.7 (7.48)
	208/208, 600/208, 400/400, 600/600, 220/208	33.8 (8.51)
150 KVA	480/208, 480/480	35.6 (8.98)
	208/208, 600/208, 600/600, 220/208	45.5 (11.47)
	400/400	40.5 (10.21)
160 KVA	480/208, 480/480	35.6 (8.98)
	208/208, 600/208, 600/600, 220/208	45.5 (11.47)
	400/400	40.5 (10.21)

**15% higher heat rejection required with optional input transformer.*

5. Recommended minimum clearance over the UPS module is 304.8 mm (12 in.). Required for cooling air exhaust: approximately 920 liters/sec (1950 cfm).
6. Battery voltage is computed at 2 volts per cell as defined by Article 480 of the NEC. Rated battery current is computed at 1.8 volts per cell.
7. The battery wiring used between the battery and the UPS should not allow a voltage drop of more than 1% of nominal DC voltage at rated battery current.
8. A battery disconnect switch is recommended, and may be required by NEC or local codes when batteries are remotely located. The battery disconnect switch may be supplied as an accessory, and should be installed between battery and UPS.
9. If the conductors used for DC input from the battery cabinet(s) to the UPS are those provided by the UPS manufacturer, and the UPS and battery cabinet are manufactured by the same supplier, then it is acceptable if they do not meet the noted minimum conductor sizes.

DESCRIPTION:	INSTALLATION NOTES	
DRAWING NO:	164200292-1	SHEET: 8 of 14
REVISION: E	DATE: 041500	

1. Table M lists the maximum rating for input circuit breakers.

Table M. Maximum Input Circuit Breaker Ratings					
Powerware System	Input Voltage Rating				
	208V	220V	400V	480V	600V
Powerware 9315 160	700	700	400	300	250
Powerware 9315 150	700	700	350	300	250
Powerware 9315 130	N/A	N/A	300	N/A	N/A
Powerware 9315 125	N/A	N/A	300	N/A	N/A

2. Source protection for the optional input transformer should be treated as if you were supplying a three phase transformer, to allow for transformer magnetization inrush current.
3. Source protection for the AC input should be treated as if you were supplying a 200 kVA three phase transformer, to allow for filter inrush current.
4. Source protection for the input to the bypass section should be treated as if you were supplying a 200 kVA three phase transformer, to allow for transformer magnetization inrush current.
5. The input breaker (CB1) has a trip rating of 250 amps AT and an amp interrupting capability (AIC) of 25,000 in symmetrical RMS amps. See Table N:

Table N. Equivalent Transformer Size for Determining Inrush	
Standard Input (Auto Transformer)	150 kVA
Optional Input Isolation Transformer	200 kVA

6. The input and bypass three phase feeds should be symmetrical about ground, due to the existence of voltage surge protection devices.
7. The line-to-line unbalanced output capability of the UPS is limited only by the full load per phase current values for AC output to critical load shown in Tables H through J. The recommended line-to-line load unbalance is 50% or less.
8. Table O lists the maximum rating for output circuit breakers.

Table O. Maximum Output Circuit Breaker Ratings				
Powerware System	Output Voltage Rating			
	208V	400V	480V	600V
Powerware 9315 160	600	300	250	200
Powerware 9315 150	600	300	225	200
Powerware 9315 130	N/A	250	N/A	N/A
Powerware 9315 125	N/A	225	N/A	N/A

DESCRIPTION:	INSTALLATION NOTES		
DRAWING NO:	164200292-1	SHEET:	9 of 14
REVISION:	E	DATE:	041500

1. Your UPS equipment's operating environment must meet the size and weight requirements shown in Table P, according to your UPS system configuration:
2. The basic environmental requirements for operation of the UPS system are:

Ambient Temperature Range: 0–40° C (32–104° F)

Recommended Operating Range: 20–25° C (68–77° F)

Maximum Relative Humidity: 95%

Table P. Equipment Weight and Point Loading		
<i>Component</i>	<i>Weight Kg (lb)</i>	<i>Point Loading Kg (lb)</i>
UPS Cabinet (Powerware 9315 150 & 160) (480/480 & 480/208 Systems)	1429 (3150)	6 at 238 (525)
UPS Cabinet (Powerware 9315 150 & 160) (208/208, 600/208, 600/600, & 220/208 Systems)	2268 (5000)	6 at 378 (833)
UPS Cabinet (Powerware 9315 150 & 160) (400/400 Systems)	1803 (3975)	6 at 301 (663)
UPS Cabinet (Powerware 9315 125 & 130) (400/400 Systems)	1429 (3150)	6 at 238 (525)
Transformer Cabinet (maximum)	636 (1400)	4 at 160 (350)
PDM Cabinet	226 (500)	4 at 57 (125)
Battery Cabinets:		
Series 685–J14	869 (1915)	4 at 217 (479)
Series 685–J17	1111 (2450)	4 at 278 (613)
Series 1085–J27	1429 (3150)	8 at 179 (394)
Series 1085–J31	1588 (3500)	8 at 199 (438)
Series 1085–J37	1708 (3765)	8 at 214 (471)
Series 1085–J47	2178 (4800)	8 at 272 (600)

<i>DESCRIPTION:</i>	INSTALLATION NOTES	
<i>DRAWING NO:</i>	164200292–1	<i>SHEET:</i> 10 of 14
<i>REVISION:</i>	E	<i>DATE:</i> 041500

Communications Panel

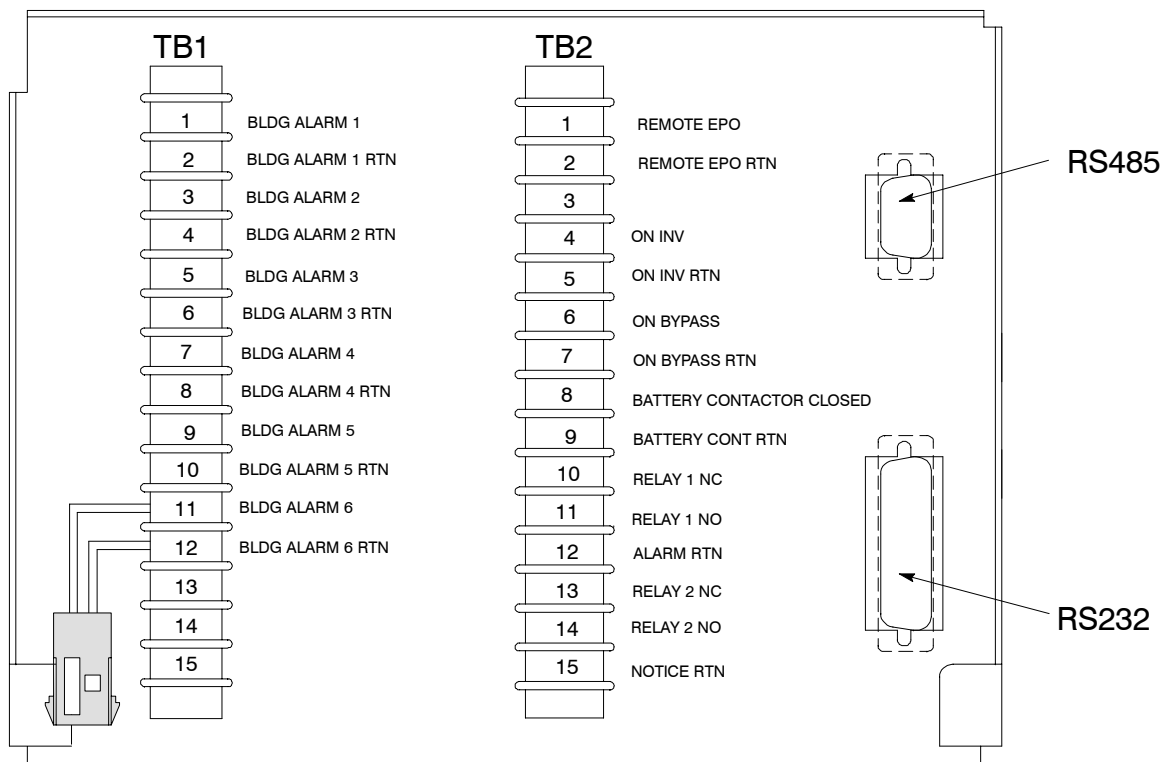

NOTE: All building alarm inputs or remote features require an isolated normally open contact or switch (rated at 24 VDC, 20mA minimum) connected between the alarm input and common terminal as shown. All control wiring and relay and switch contacts are customer provided.

NOTE: Regardless of assignment, alarms display as Building Alarm 1, Building Alarm 2, etc., on Monitor Panel. Use twisted pair wires for each alarm input and common.

DESCRIPTION: INSTALLATION NOTES	
DRAWING NO: 164200292-1	SHEET: 11 of 14
REVISION: C	DATE: 081596

Table Q. Communications Panel Inputs and Outputs

TB1 Pin #	Name	Description
1	BLDG ALARM 1	Programmable UPS alarm. Activated by a remote contact closure.
2	BLDG ALARM 1 RTN	
3	BLDG ALARM 2	Programmable UPS alarm. Activated by a remote contact closure.
4	BLDG ALARM 2 RTN	
5	BLDG ALARM 3	Programmable UPS alarm. Activated by a remote contact closure.
6	BLDG ALARM 3 RTN	
7	BLDG ALARM 4	Programmable UPS alarm. Activated by a remote contact closure.
8	BLDG ALARM 4 RTN	
9	BLDG ALARM 5	Programmable UPS alarm. Activated by a remote contact closure.
10	BLDG ALARM 5 RTN	
11	BLDG ALARM 6	Programmable UPS alarm. Activated by a remote contact closure.
12	BLDG ALARM 6 RTN	

Table R. Communications Panel Inputs and Outputs

TB2 Pin #	Name	Description
1	REMOTE EPO	Contacts used to activate remote EPO of UPS.
2	REMOTE EPO RTN	
3		
4	ON INV	Contacts used to indicate On Inverter status of UPS.
5	ON INV RTN	
6	ON BYPASS	Contacts used to indicate On Bypass status of UPS.
7	ON BYPASS RTN	
8	BATTERY CONTACTOR CLOSED	Contacts used to indicate UPS Battery Contactor is closed.
9	BATTERY CONT RTN	
10	RELAY 1 NC	General purpose NO and NC relay contacts.
11	RELAY 1 NO	
12	ALARM RTN	
13	RELAY 2 NC	General purpose NO and NC relay contacts.
14	RELAY 2 NO	
15	NOTICE RTN	

<i>DESCRIPTION:</i> INSTALLATION NOTES		
<i>DRAWING NO:</i>	164200292-1	<i>SHEET:</i> 12 of 14
<i>REVISION:</i> C	<i>DATE:</i> 081596	

1. Use Class 1 wiring methods (as defined by the NEC), for control wiring. Install the control wiring in separate conduit from the power wiring. The wire should be rated at 24 volts, 1 amp minimum.
2. Refer to Tables S, T, and U, and to applicable chapters for information about installing control wiring for options and accessories.

Table S. Control Wiring Terminations		
<i>Terminal</i>	<i>Description</i>	<i>Terminal Function</i>
TB1	Terminal Block	Building Alarms (optional, up to 6)
		Generator Interface
TB1 TB2 TB2	Terminal Block	Remote EPO
		“On Inverter” Monitoring
		“On Bypass” Monitoring
		Summary Alarm & Notice Contacts

Table T. Summary Alarm Relay Contacts		
CONTACT RATING:		
Maximum Switched Voltage	32 VAC	42 VDC
Maximum Carrying Current	1A	

<i>DESCRIPTION:</i>	INSTALLATION NOTES	
<i>DRAWING NO:</i>	164200292-1	<i>SHEET:</i> 13 of 14
<i>REVISION:</i>	C	<i>DATE:</i> 081596

3. The Remote EPO feature opens all breakers and contactors in the UPS cabinet and isolates power from your critical load. Local electrical codes may also require tripping upstream protective devices to the UPS.

Table U. Remote EPO

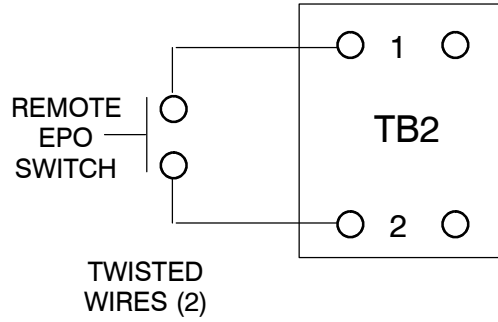

Remote EPO switch rating is 24 VDC.
1 amp minimum if supplied by user.

NOTE: *This switch must be a dedicated switch, and not tied into any other circuits.*

DESCRIPTION: INSTALLATION NOTES	
DRAWING NO: 164200292-1	SHEET: 14 of 14
REVISION: B	DATE: 081596

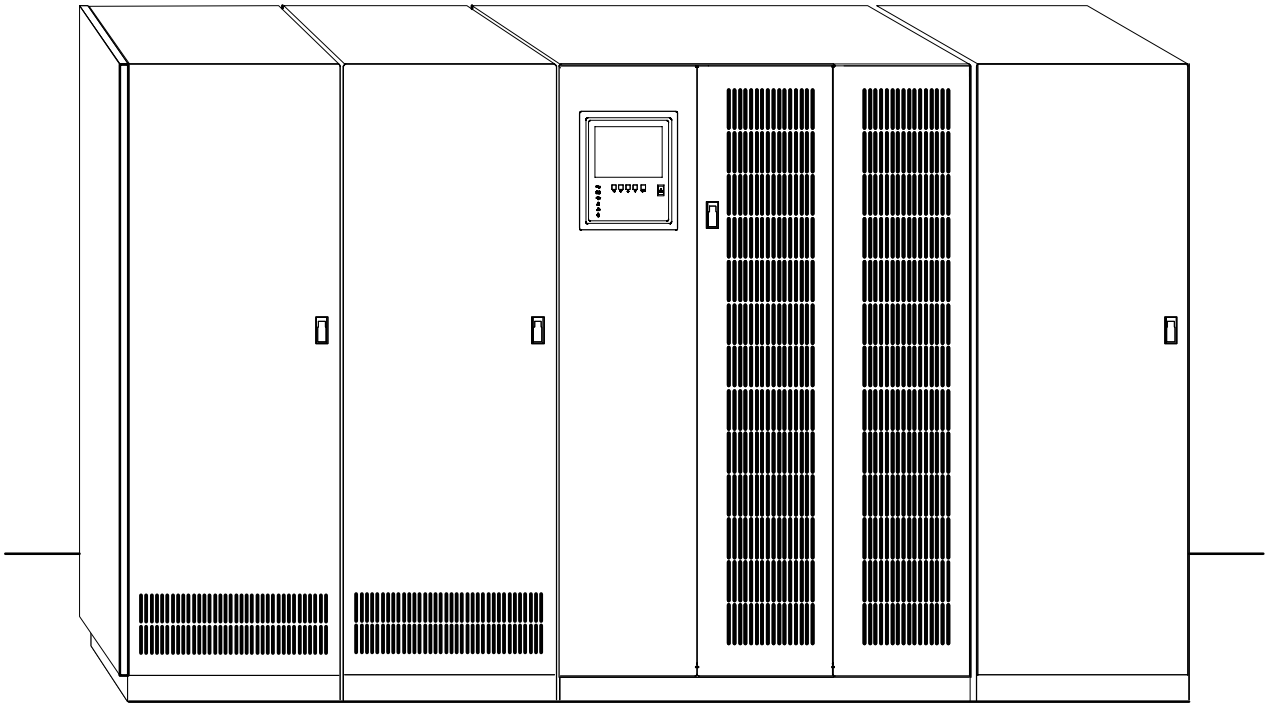

*PDM CABINET
(optional)*

*INPUT
TRANSFORMER
CABINET
(optional)*

*UPS
CABINET*

*BATTERY
CABINET
(optional
up to four)*

<i>DESCRIPTION:</i> TYPICAL UPS SYSTEM	
<i>DRAWING NO:</i> 164200292-2	<i>SHEET:</i> 1 of 1
<i>REVISION:</i> B	<i>DATE:</i> 010496

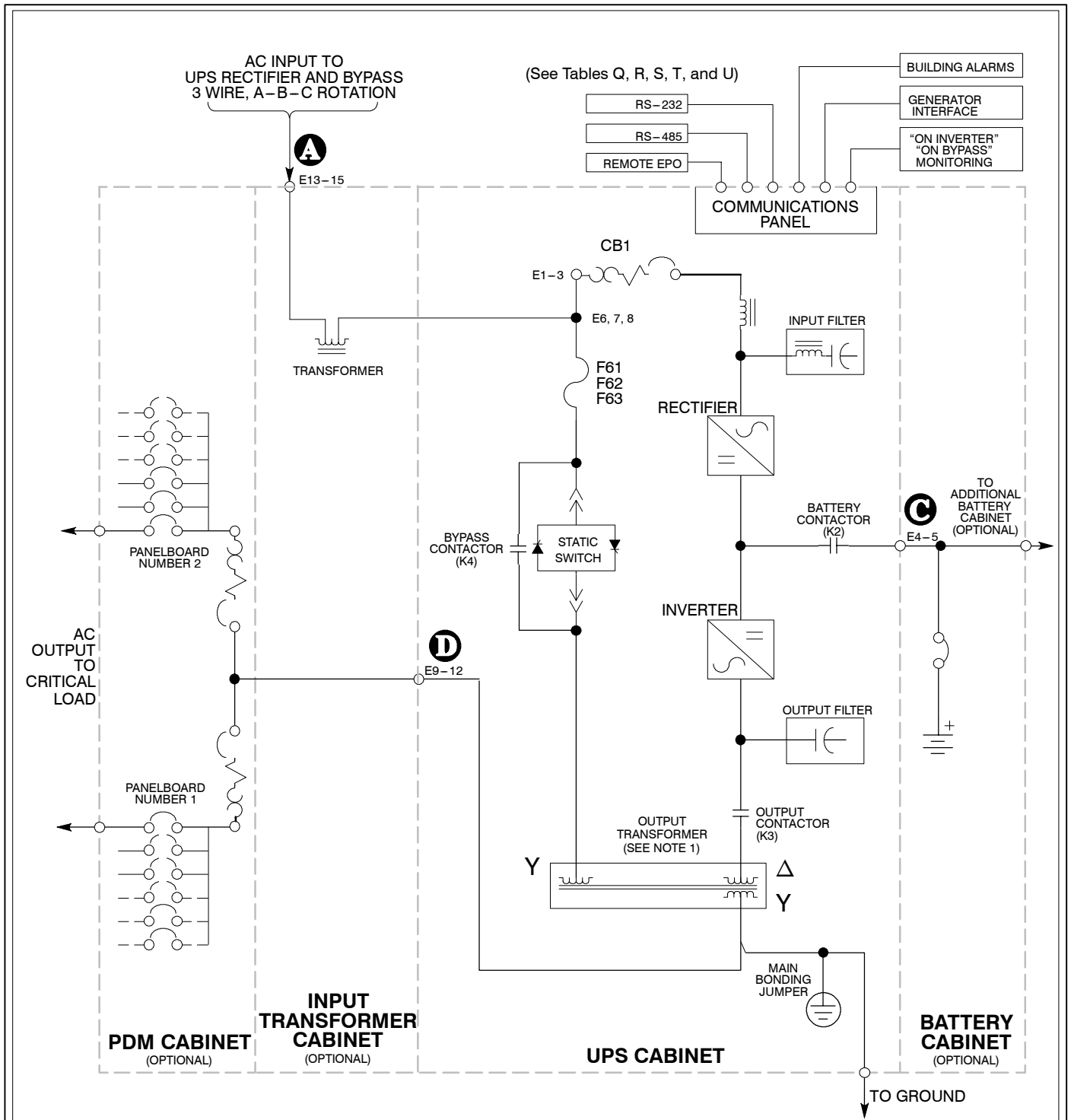

UPS SYSTEM WITH 208V INPUT

NOTE 1: There is a zero degree phase shift through the bypass windings of the output transformer.

DESCRIPTION:	ONLINE DRAWINGS OF UPS SYSTEM	
DRAWING NO:	164200292-3	SHEET: 1 of 7
REVISION:	C	DATE: 081596

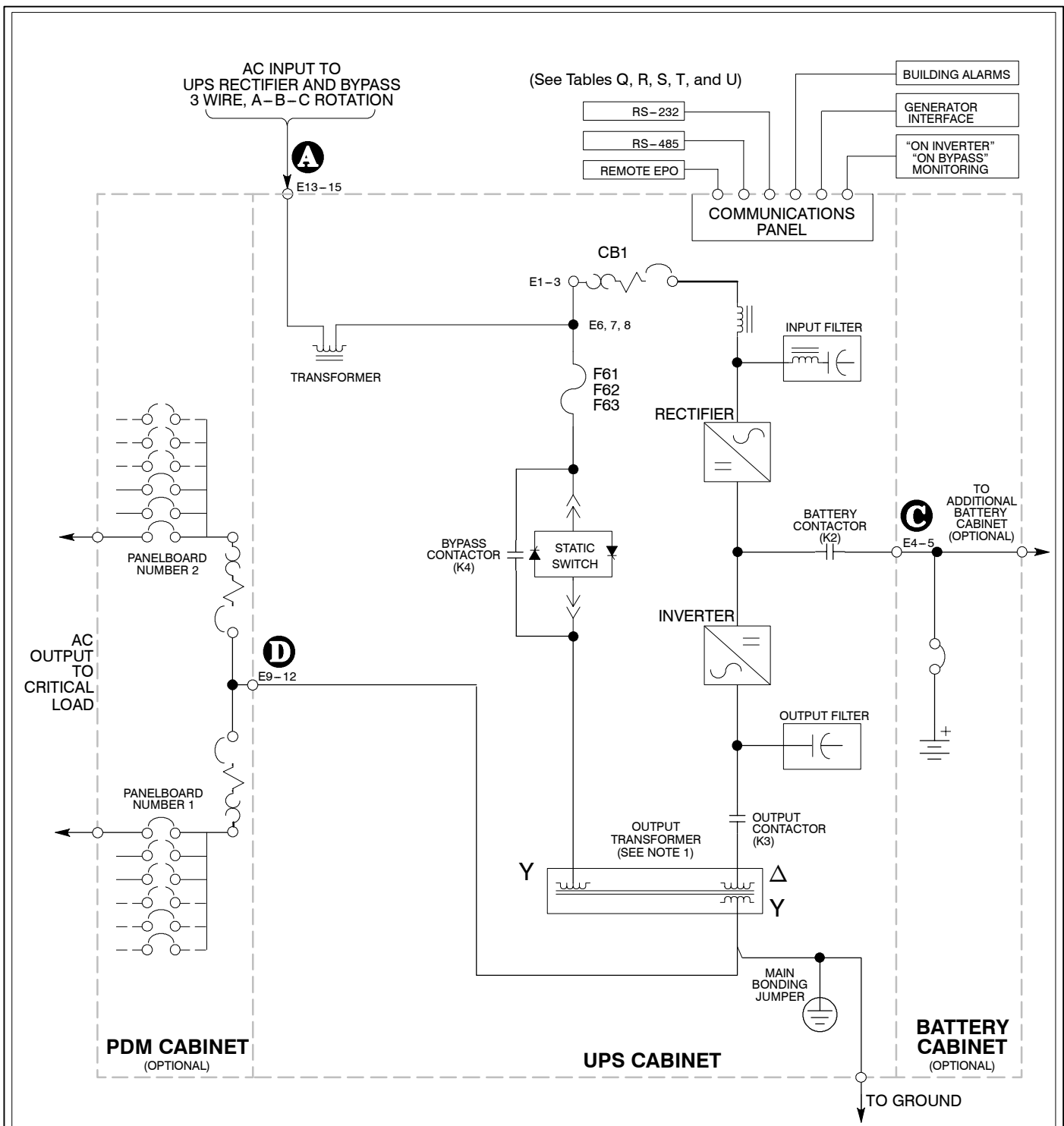

UPS SYSTEM WITH 600V INPUT

NOTE 1: There is a zero degree phase shift through the bypass windings of the output transformer.

DESCRIPTION:	ONLINE DRAWINGS OF UPS SYSTEM	
DRAWING NO:	164200292-3	SHEET: 2 of 7
REVISION:	C	DATE: 081596

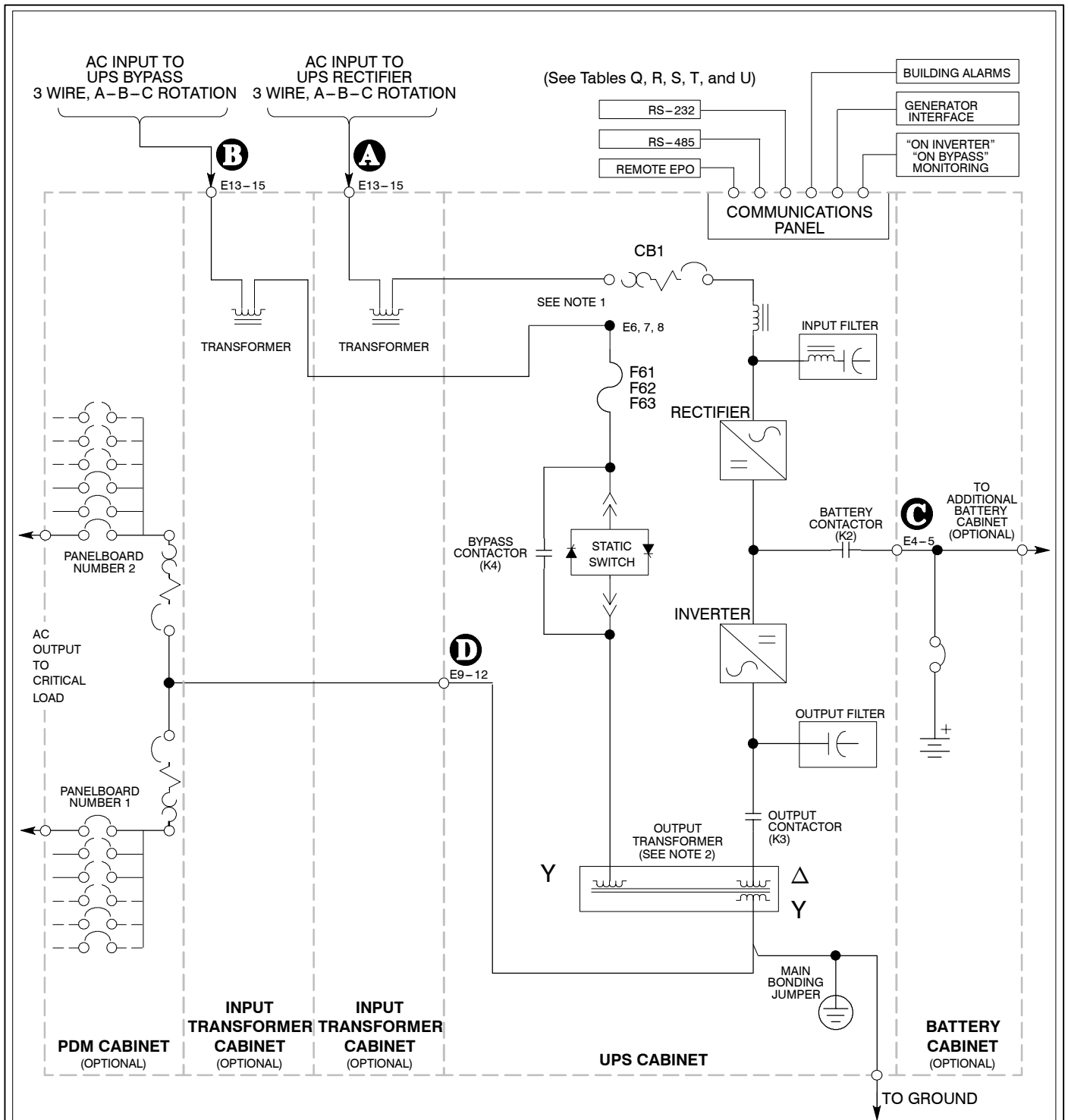

**UPS SYSTEM WITH DUAL INPUTS
(208V INPUT)**

NOTE 1: Remove power jumpers between CB1 and F61, F62, and F63 if present.

NOTE 2: There is a zero degree phase shift through the bypass windings of the output transformer.

DESCRIPTION:		ONLINE DRAWINGS OF UPS SYSTEM	
DRAWING NO:	164200292-3	SHEET:	3 of 7
REVISION:	C	DATE:	081596

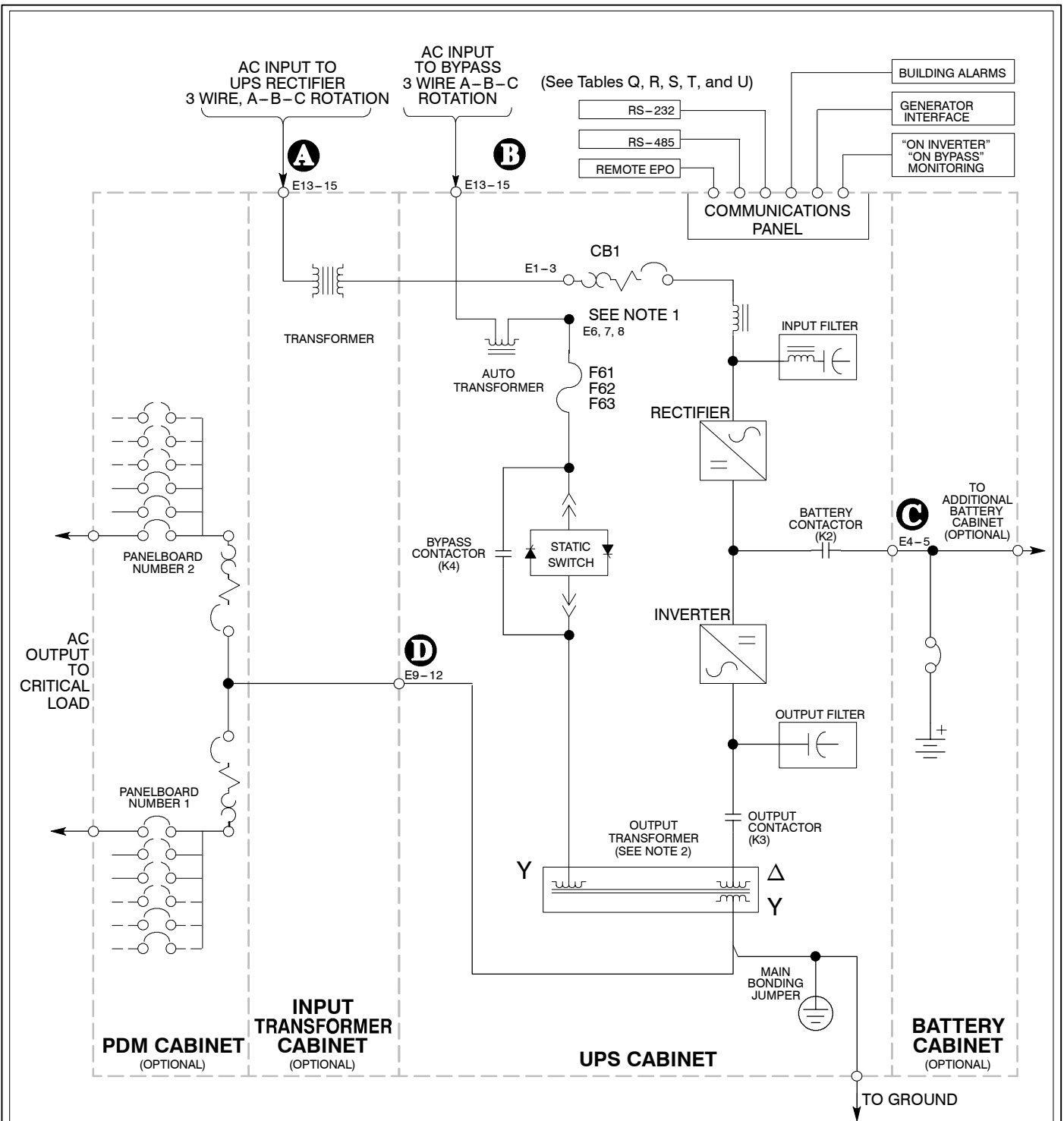

**UPS SYSTEM WITH DUAL FEED OR OPTIONAL INPUT ISOLATION TRANSFORMER
(600V INPUT)**

NOTE 1: Remove power jumpers between CB1 and F61, F62, and F63 if present.

NOTE 2: There is a zero degree phase shift through the bypass windings of the output transformer.

DESCRIPTION:	ONLINE DRAWINGS OF UPS SYSTEM	
DRAWING NO:	164200292-3	SHEET: 4 of 7
REVISION:	C	DATE: 081596

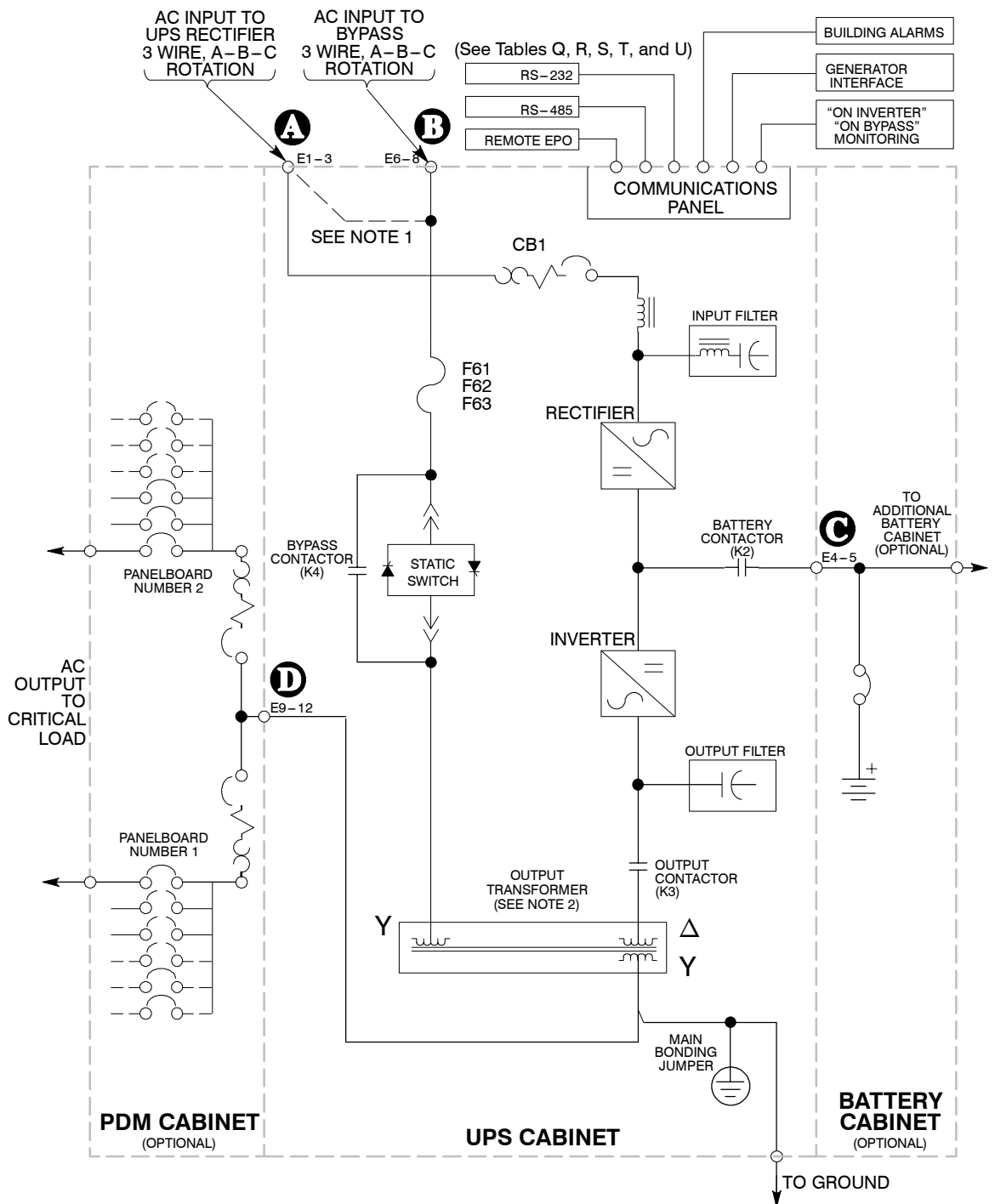

UPS SYSTEM WITH 480V INPUT, SINGLE OR DUAL FEED

NOTE 1: Optional jumper for single feed. Use terminals E6, E7, and E8 for connection. See Table J, row **B** for wire rating.

NOTE 2: There is a zero degree phase shift through the bypass windings of the output transformer.

DESCRIPTION:	ONLINE DRAWINGS OF UPS SYSTEM	
DRAWING NO:	164200292-3	SHEET: 5 of 7
REVISION:	C	DATE: 081596

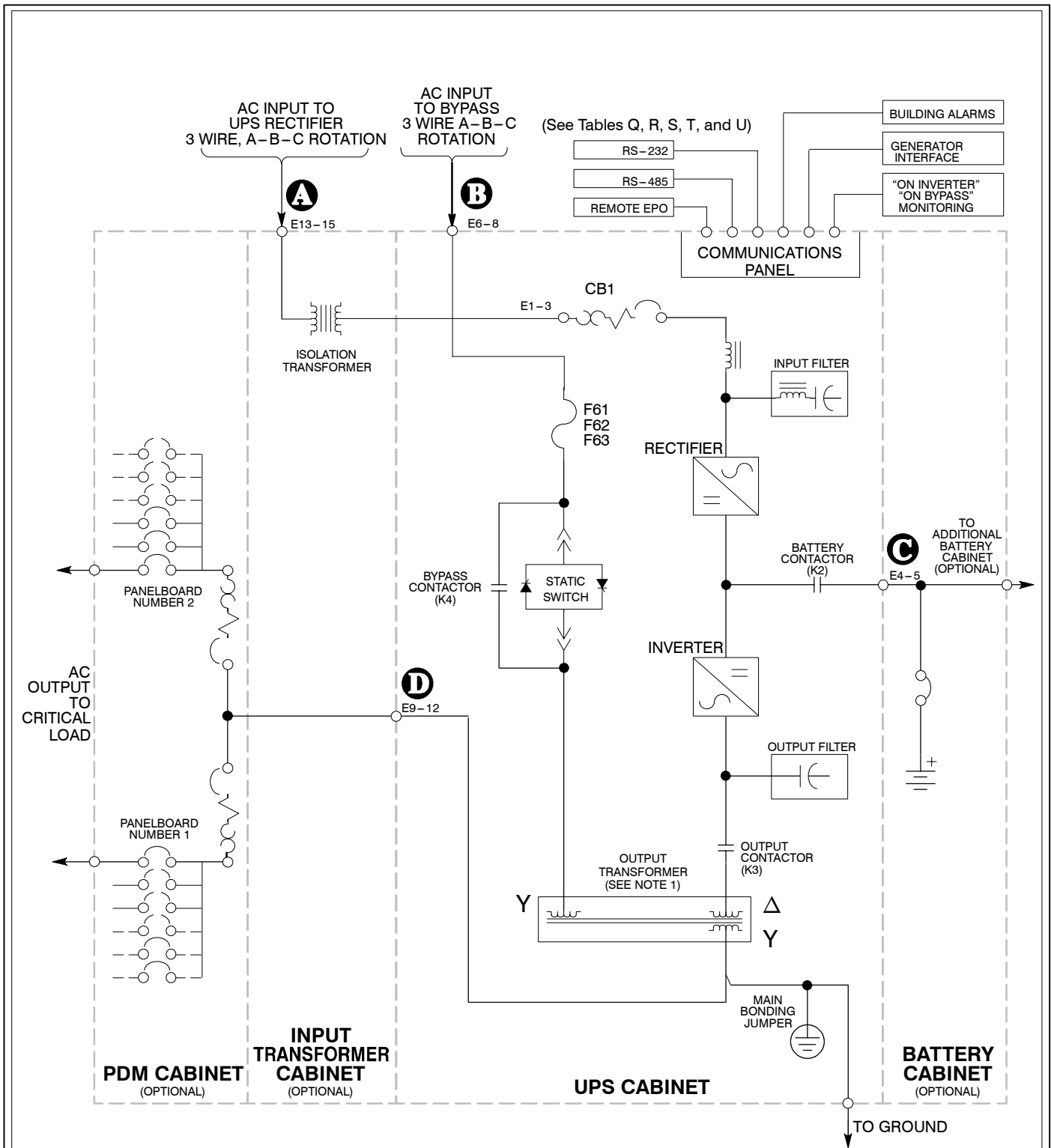

**UPS SYSTEM WITH OPTIONAL INPUT ISOLATION TRANSFORMER
(480V INPUT)**

NOTE 1: There is a zero degree phase shift through the bypass windings of the output transformer.

DESCRIPTION:		ONLINE DRAWINGS OF UPS SYSTEM	
DRAWING NO:	164200292-3	SHEET:	6 of 7
REVISION:	C	DATE:	081596

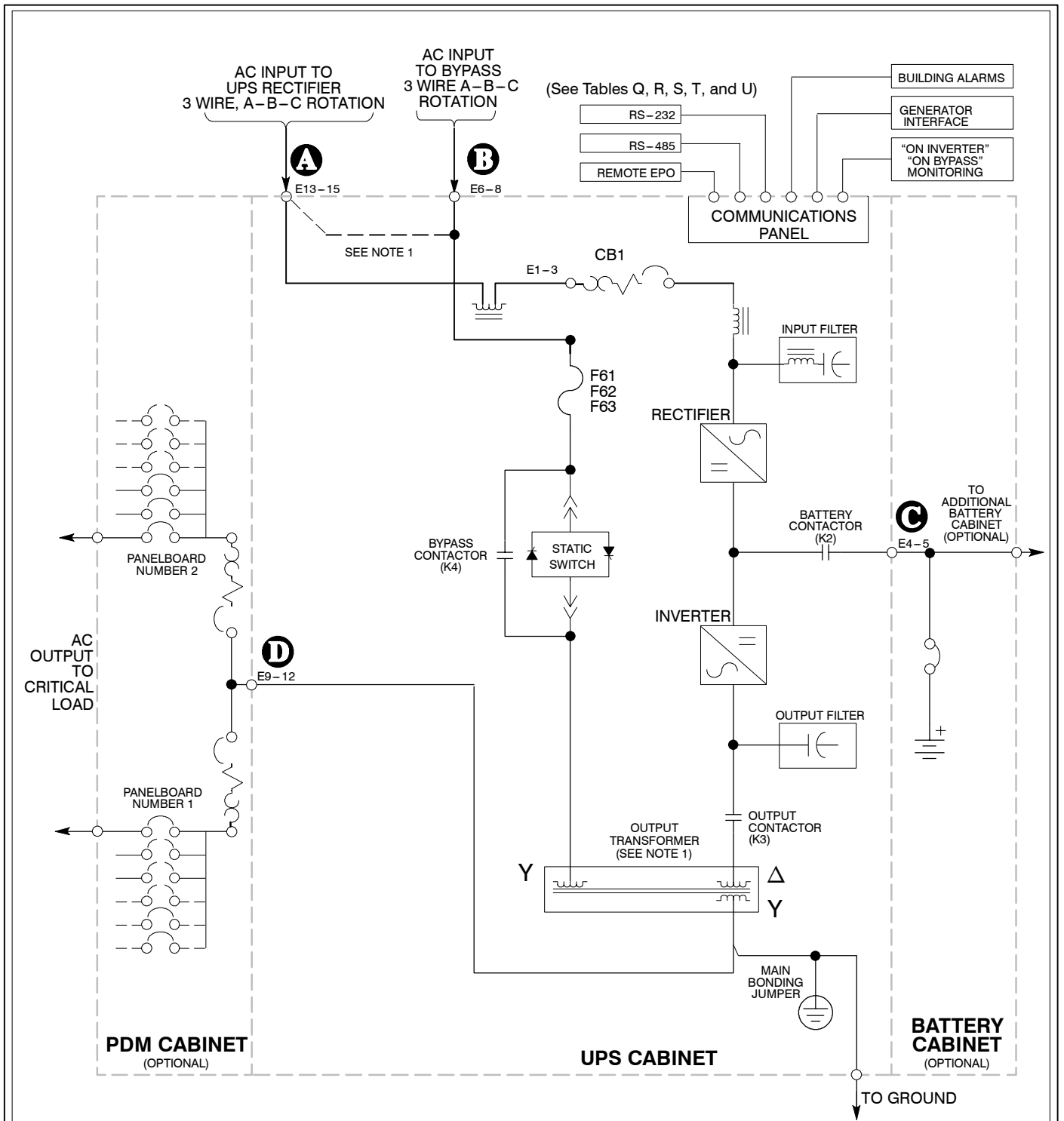

UPS SYSTEM WITH 400V INPUT, SINGLE OR DUAL FEED

NOTE 1: Optional jumper for single feed. Use terminals E6, E7, and E8 for connection. See Table L, row **B** for wire rating.

NOTE 2: There is a zero degree phase shift through the bypass windings of the output transformer.

DESCRIPTION: ONLINE DRAWINGS OF UPS SYSTEM		
DRAWING NO:	164200292-3	SHEET: 7 of 7
REVISION:	C	DATE: 081596

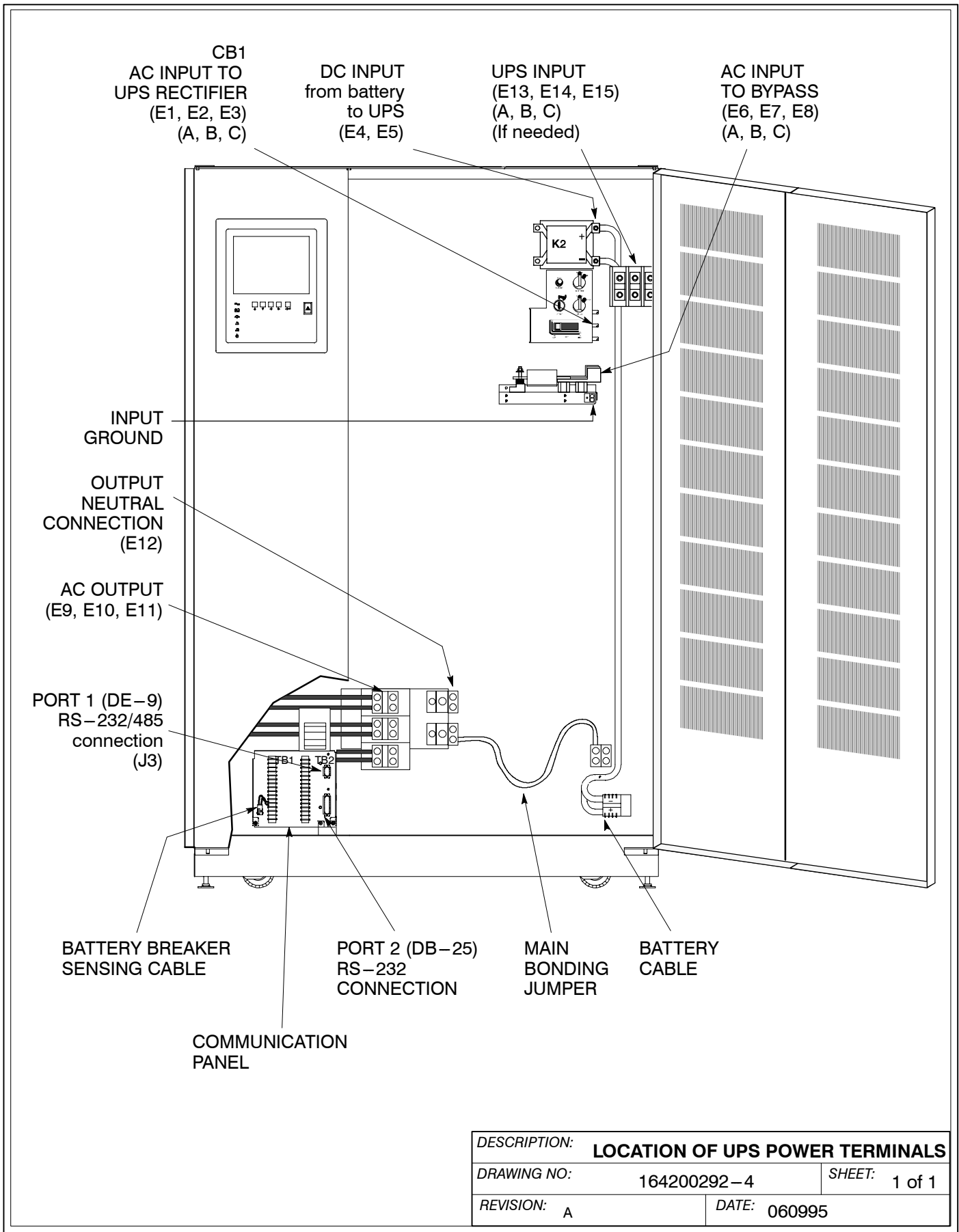

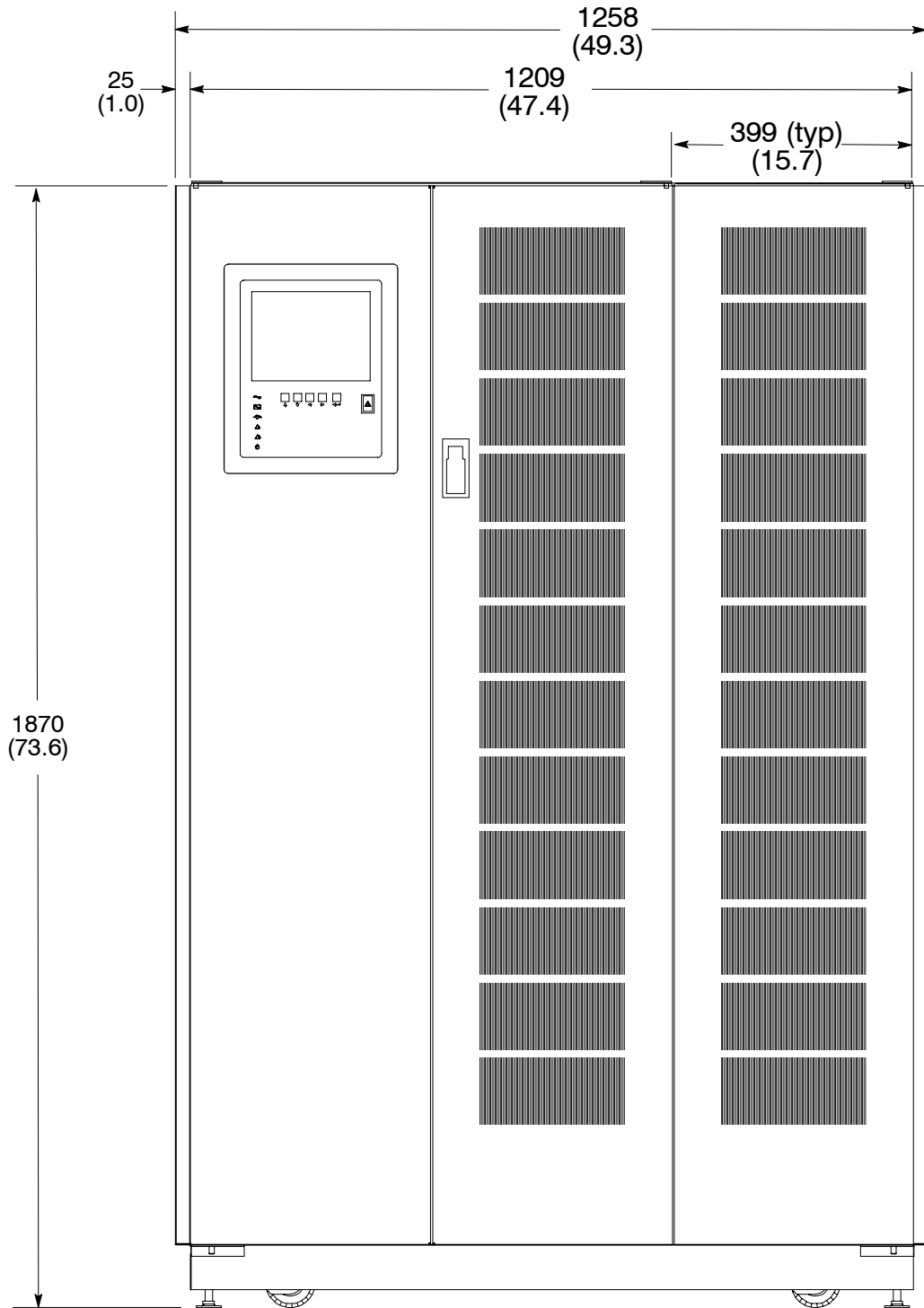

Dimensions are in millimeters (inches)

DESCRIPTION: UPS CABINET		SHEET: 1 of 2
DRAWING NO:	164200292-5	
REVISION: A	DATE: 060995	

**UPS CABINET
TOP
VIEW**

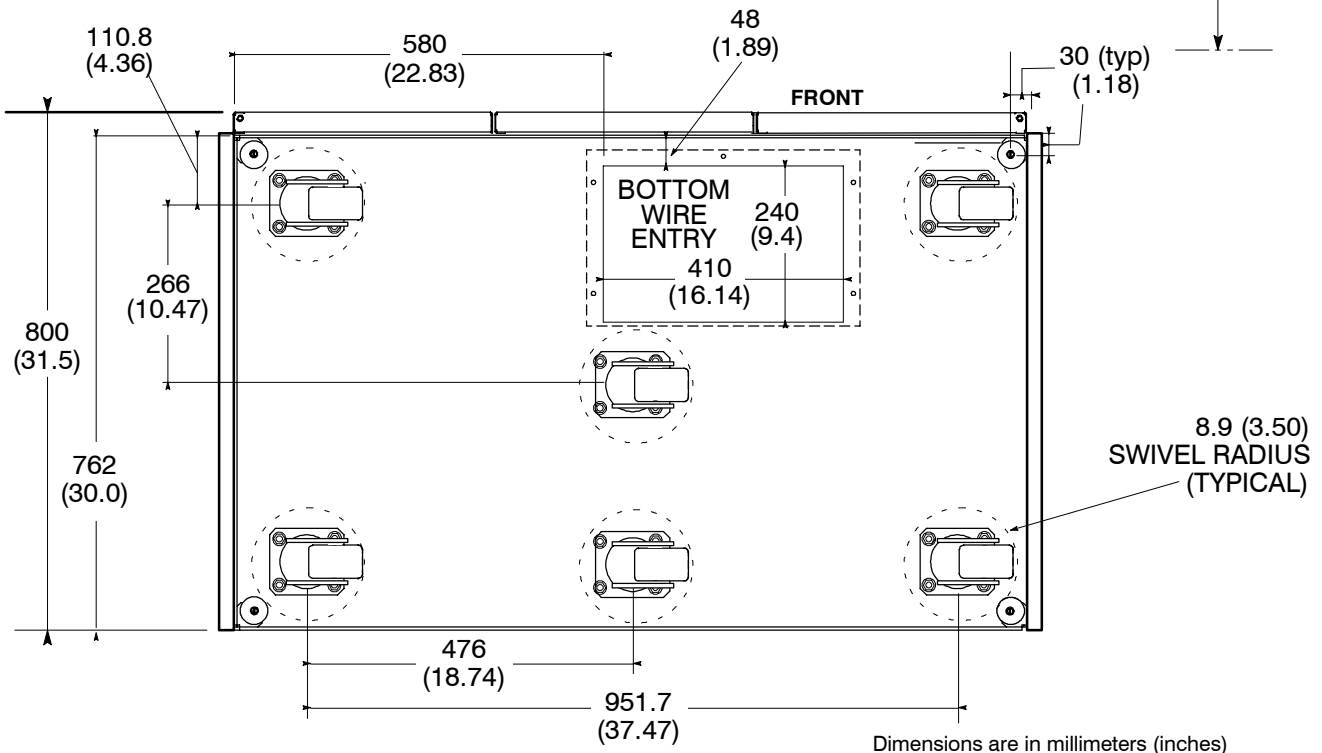
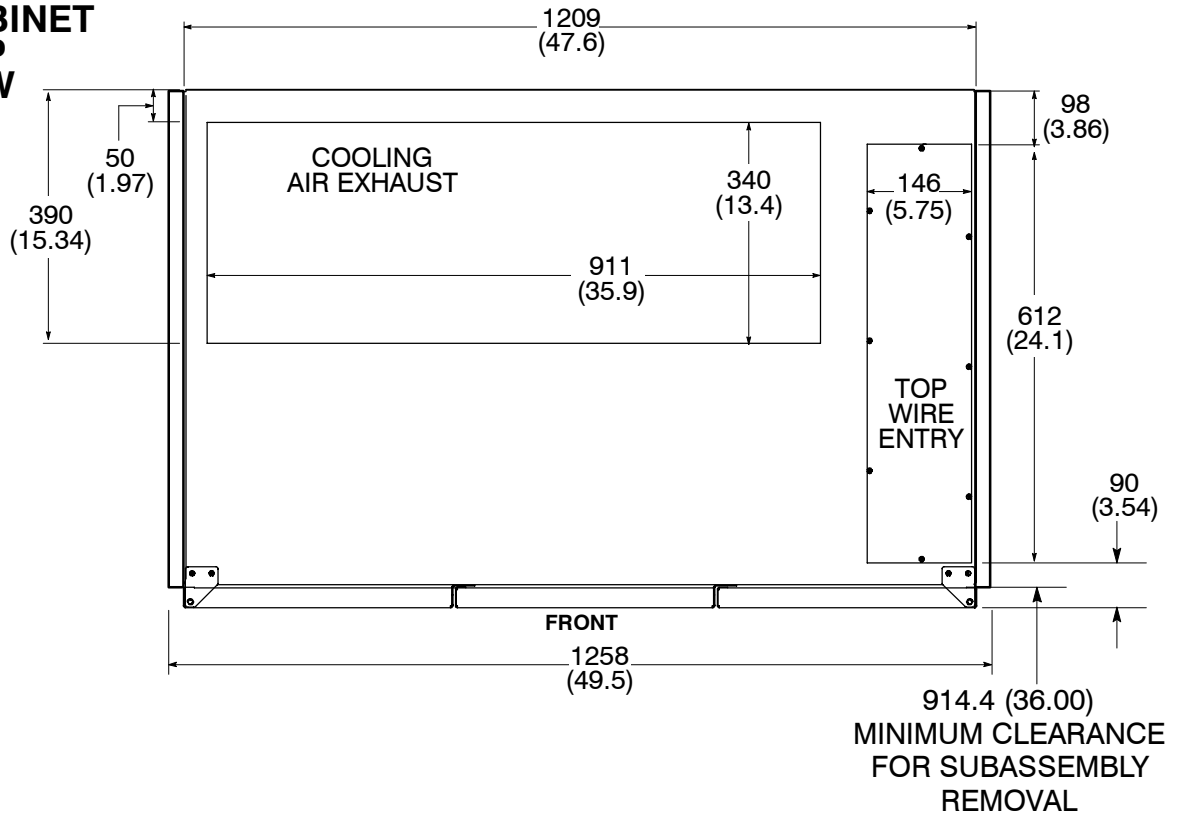

**UPS CABINET
BOTTOM
VIEW**

DESCRIPTION: UPS CABINET		
DRAWING NO:	164200292-5	SHEET: 2 of 2
REVISION: A	DATE: 060995	

TOP VIEW

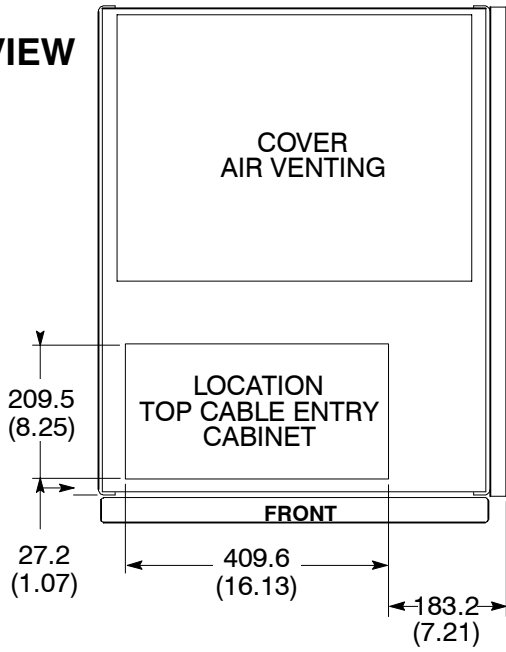

25.4
(1.00)

609.6
(24.00)

1870
(73.6)

BOTTOM VIEW

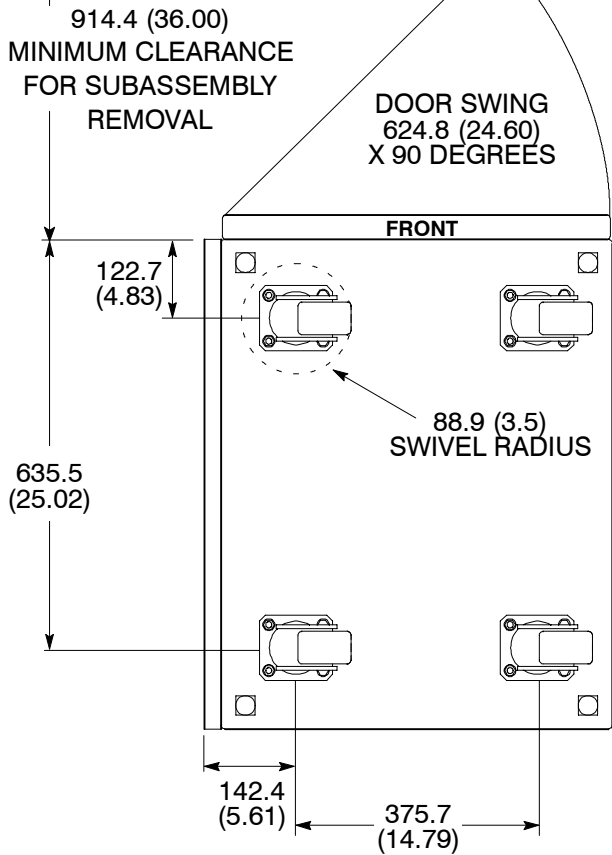

Dimensions are in millimeters (inches)

DESCRIPTION: INPUT TRANSFORMER CABINET		
DRAWING NO: 164200292-6	SHEET: 1 of 1	
REVISION: A	DATE: 060995	

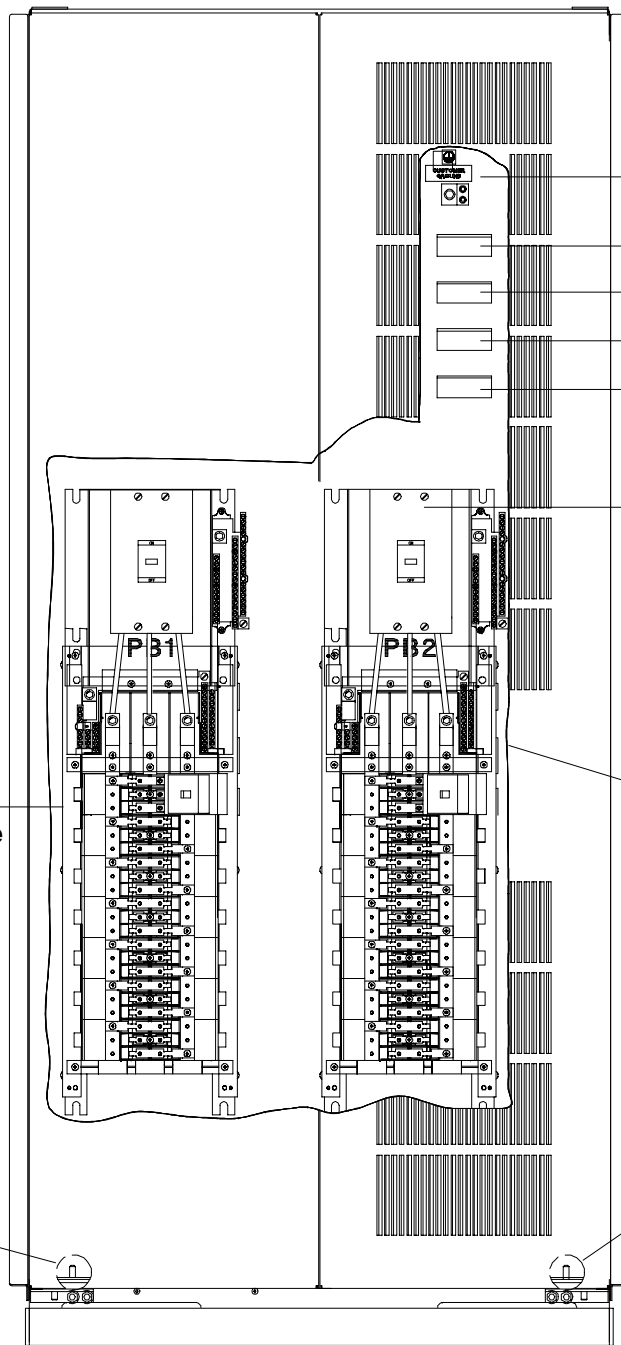

Input Ground
(2) #6-350 KCM

ØA E1

ØB E2

ØC E3

Neutral E4

PB2
(Optional)

Branches—QO Plug-On
and QOB Bolt-On Circuit
Breaker. 15-70A, 1-Pole;
15-100A 2- and 3-Pole;
125A, 2-Pole.

Grounding
Stud

42-Pole Panelboard
With Main Breaker
225A 600V Square D Type
NQOM442M225IG-NL

Grounding
Stud

NOTE 1: Refer to Powerware 9315 Power Distribution Module Installation and Operation Manual 164201061 for PDM installation and operation.

DESCRIPTION: POWER DISTRIBUTION MODULE	
DRAWING NO: 164200292-7	SHEET: 1 of 1
REVISION: E	DATE: 041500

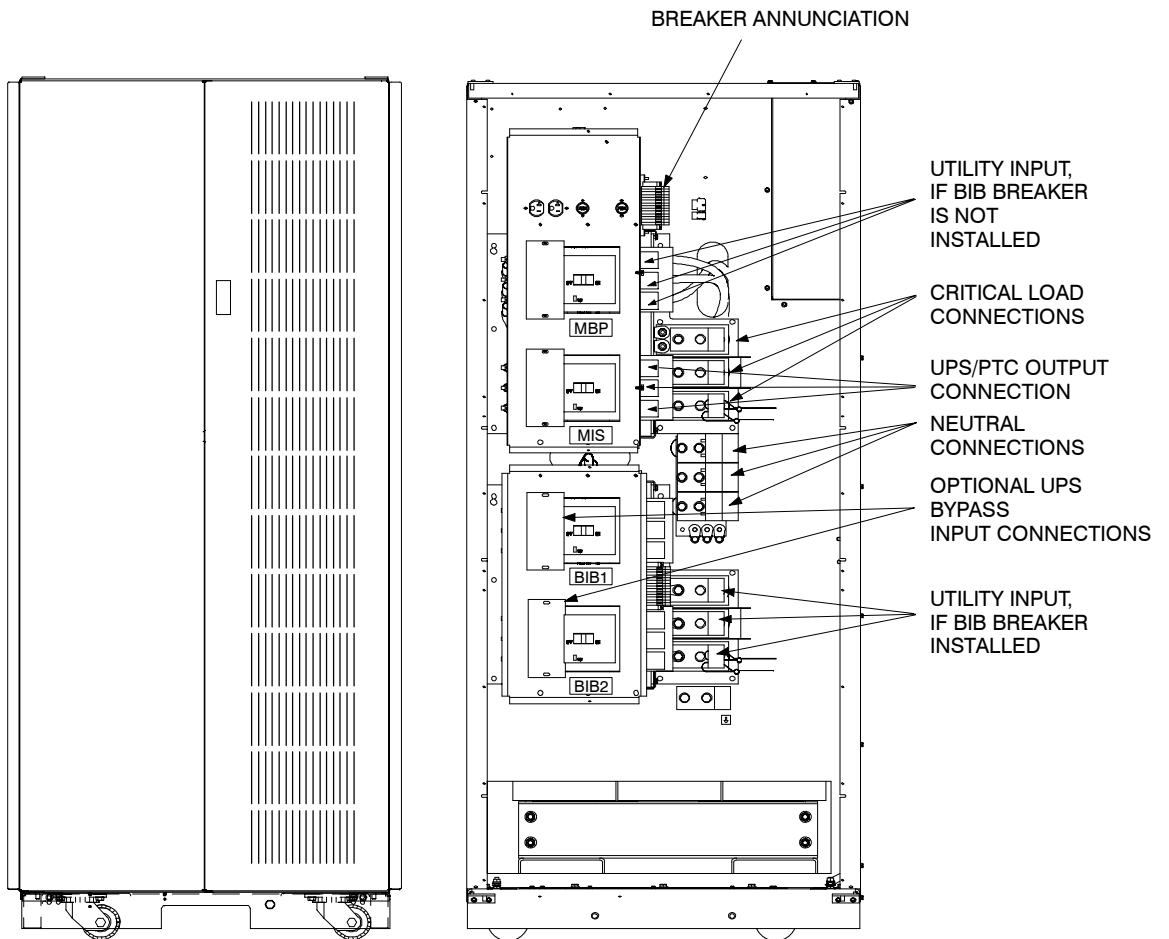

NOTE 1: Refer to Powerware 9315 Maintenance Bypass Module (MBM) Installation and Operation Manual 164201177 for MBM installation and operation.

DESCRIPTION:	MAINTENANCE BYPASS MODULE	
DRAWING NO:	164200292-8	SHEET: 1 of 1
REVISION:	E	DATE: 041500

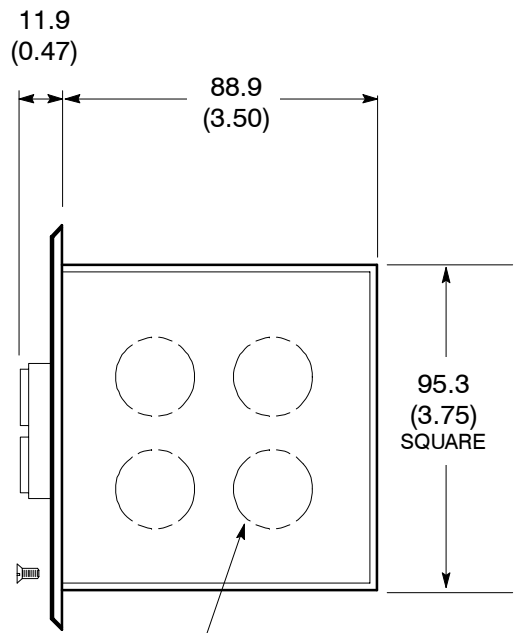
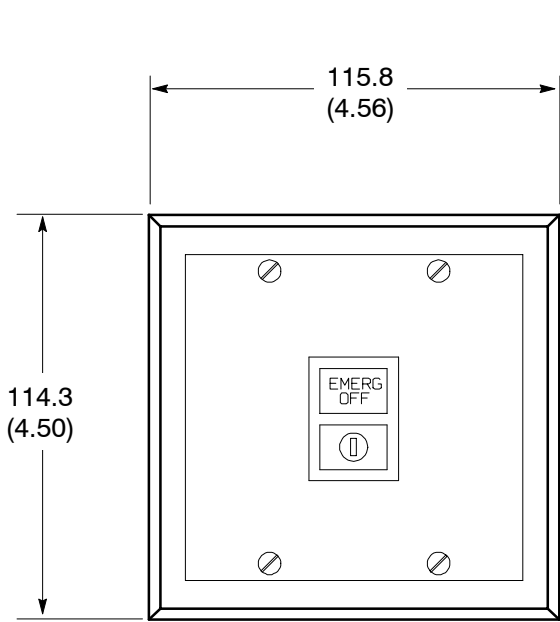

Knockout pattern
typ. 5 sides

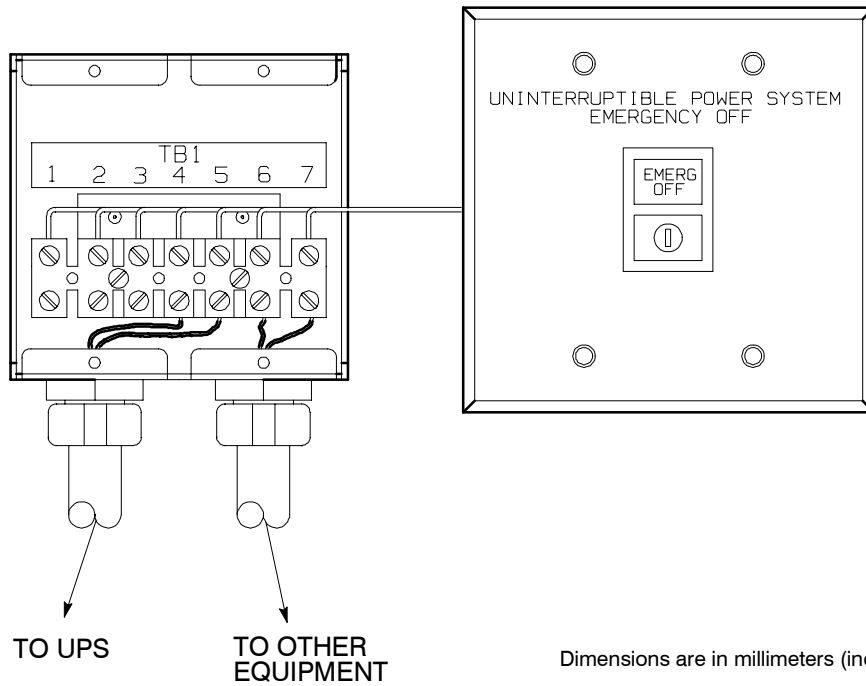

Dimensions are in millimeters (inches)

DESCRIPTION: REMOTE EMERGENCY POWER OFF		
DRAWING NO:	164200292-9	SHEET: 1 of 1
REVISION:	E	DATE: 041500

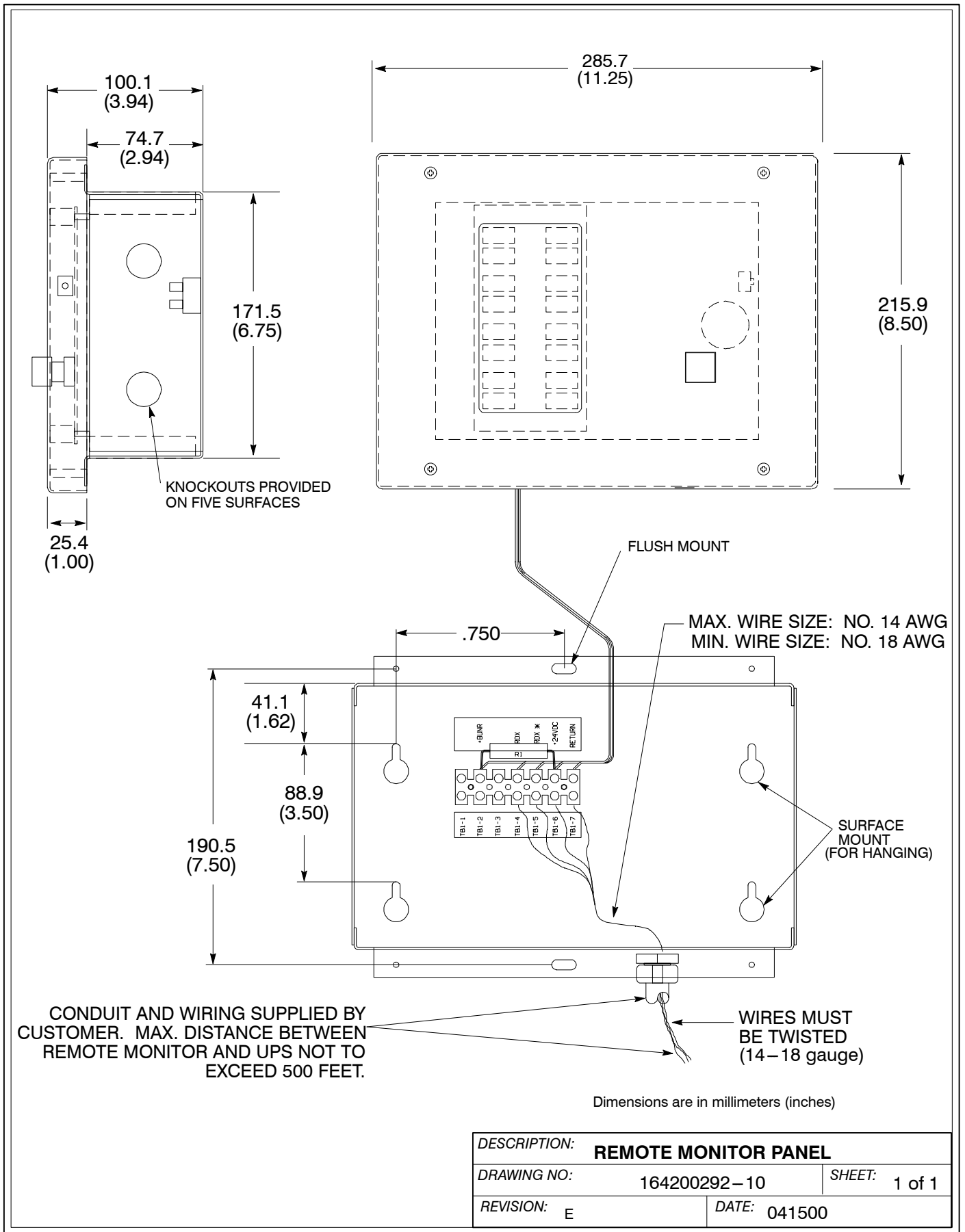

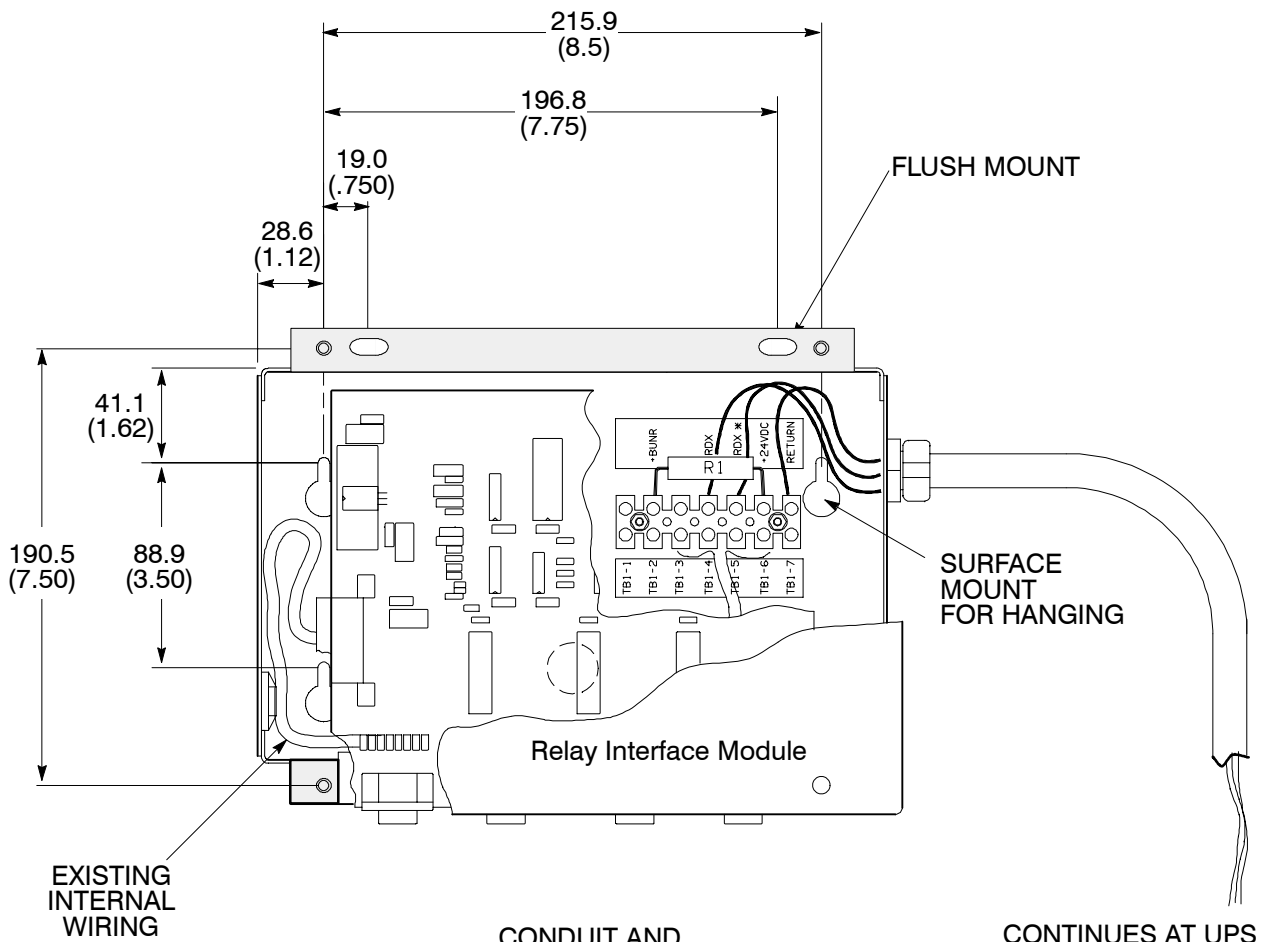

CONDUIT AND WIRING SUPPLIED BY CUSTOMER.
 Maximum distance between RIM and UPS not to exceed 500 feet. Wires must be twisted.
MAX WIRE SIZE NO. 14 AWG.
MIN WIRE SIZE NO. 18 AWG.

Dimensions are in millimeters (inches)

DESCRIPTION: RELAY INTERFACE MODULE		
DRAWING NO:	164200292-11	SHEET: 1 of 2
REVISION:	E	DATE: 041500

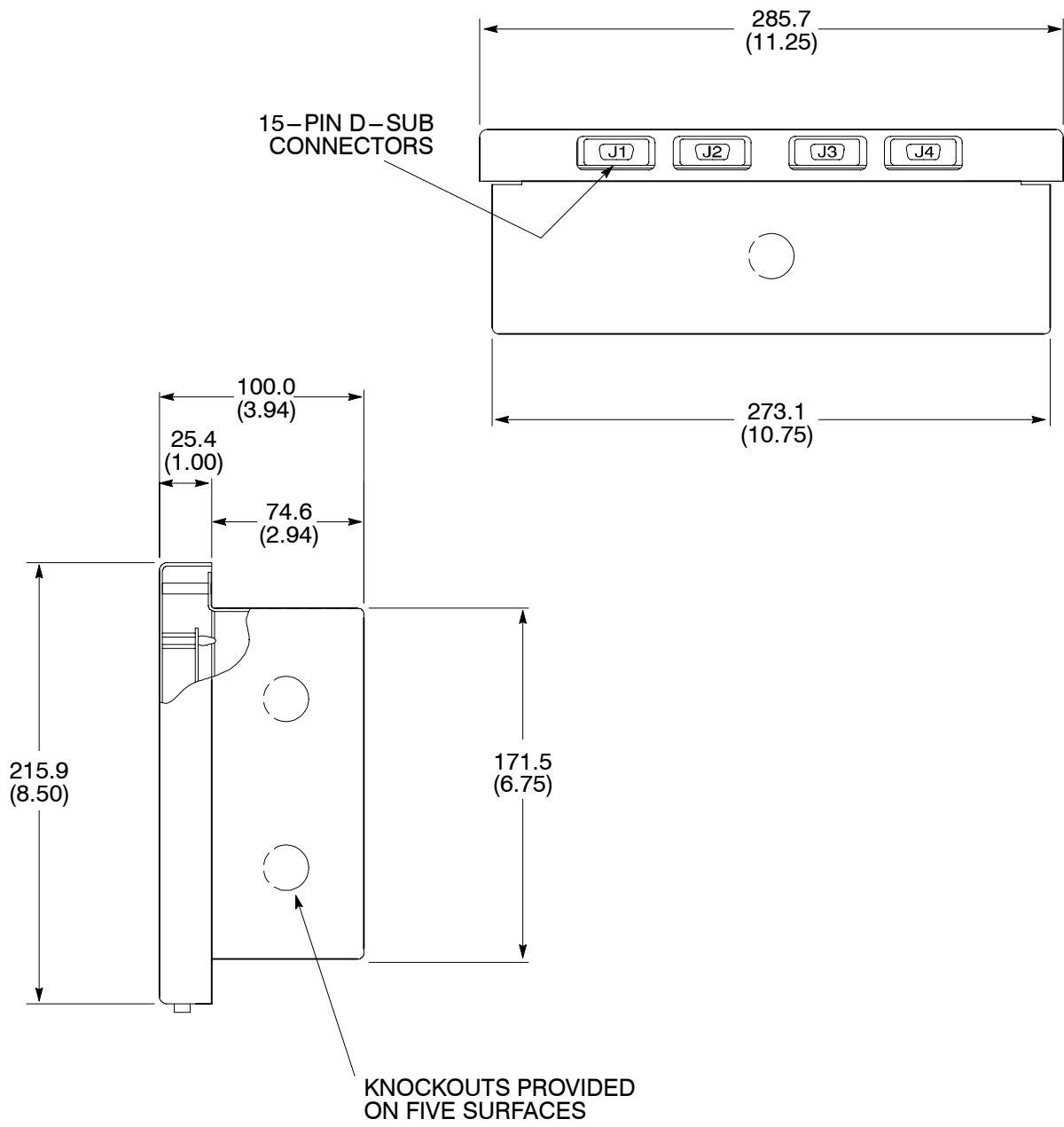

Dimensions are in millimeters (inches)

DESCRIPTION:		RELAY INTERFACE MODULE	
DRAWING NO:	164200292-11	SHEET:	2 of 2
REVISION:	E	DATE:	041500

