



ИБП Eaton / MGE EX RT - Eaton EX RT CLA Charger Module - Быстрый старт

Постоянная ссылка на страницу: <https://eaton-power.ru/catalog/eaton-mge-ex-rt/>

EX RT CLA Charger Module Quick Start

Standard Features

- EX RT CLA Charger Module is a long back-up charger to be used with a power module and external power battery cabinet.



CLA Charger Module (long backup time charger)

(Part number 86004)

Extended back-up time (up to 8 hours at full load) requires a high power battery cabinet connected to the EX 5/7/11 RT via the CLA Charger Module.



IMPORTANT The CLA Charger Module can not be used to charge the battery module (EXB). It is designed to charge the customer provided high power battery cabinet.

Battery backup time chart.

Battery Backup Time	Recommended Batteries		
	EX RT 5	EX RT 7	EX RT 11
2 hours	50 Ah	65 Ah	100 Ah
4 hours	100 Ah	130 Ah	200 Ah
8 hours	200 Ah	260 Ah	400 Ah

Total battery voltage: 240 V DC.

The battery capacity must be set within the UPS (5 Ah increment, see UPS Personalization section 3.2.).

STEP 1 EX RT CLA Charger Module Unpacking and Parts Check

CLA Module Box Contents



CLA Module Quick Start



Warranty and Product Registration



Tower Stand Extenders

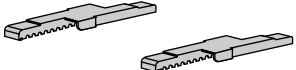

Stabilizer Bracket (4 screws included)

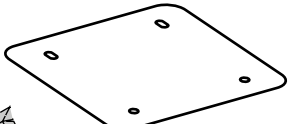

Battery Power Cable

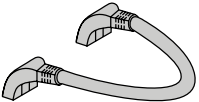

CLA Rail Kit

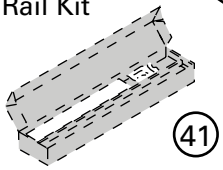

Battery Detection Cable



STEP 2 EX RT CLA Charger Module Tower Configurations

Follow the numerical sequence to assemble the footer supports as shown.

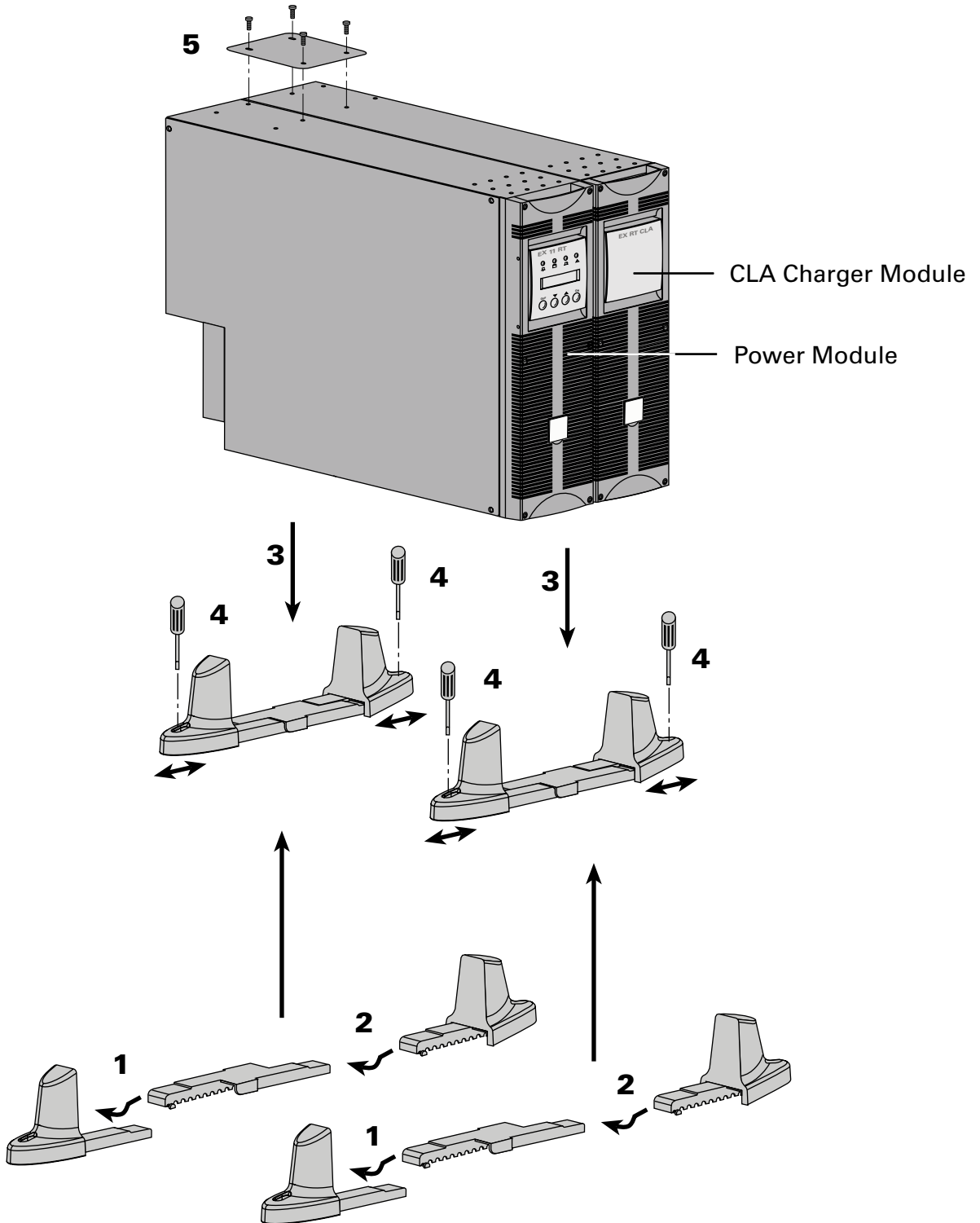

STEP 3 EX RT CLA Charger Module Rack Configuration

A. Prepare the front panel logo and LCD display for rack orientation, Apply to all modules. Power Module shown.

Stack-up sequence in Rack configuration

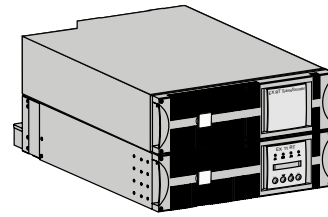
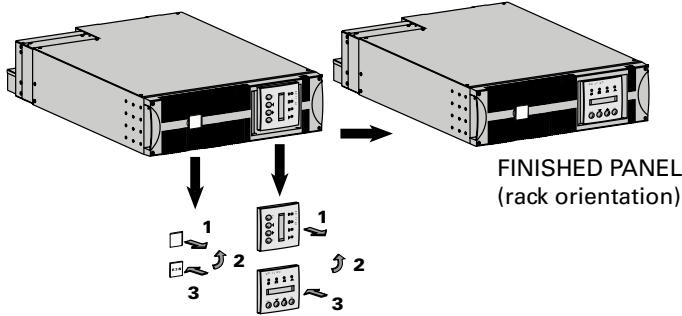

1. EX RT CLA MODULE
(Top, EX RT 5/7/11)
2. POWER MODULE
(bottom, EX RT 5/7/11)

B. Rack Installation

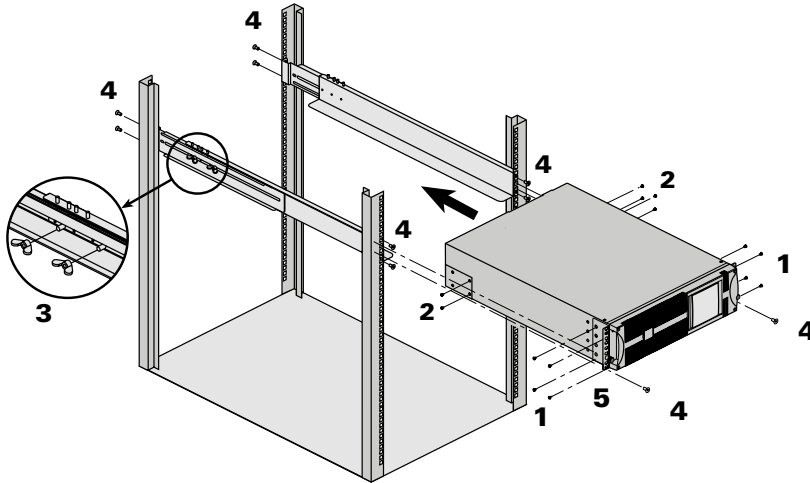

1. Attach both front mounting ear brackets to module with supplied screws. (For this step, it is possible to adjust the position of both front mounting brackets.)
2. Attach rear support brackets to module. These brackets prevent the module from sliding out of the rack.
3. Attach rails together and secure with wing nuts, and finger tighten. (both sides).
4. Attach both rails to rear and front of rack with supplied flathead screws (as shown).
5. Use caution when sliding unit into rack.
Temporarily secure unit to rack with thumb screws on front mounting brackets.
6. Secure rear support brackets to rails.

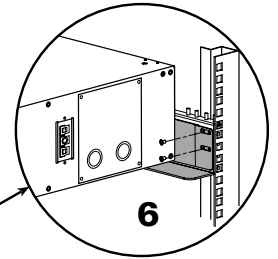
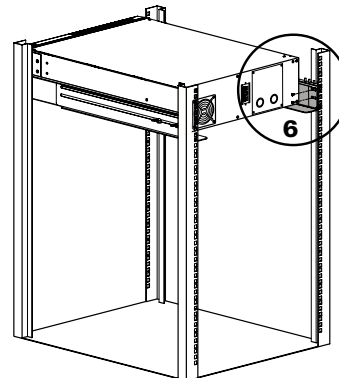
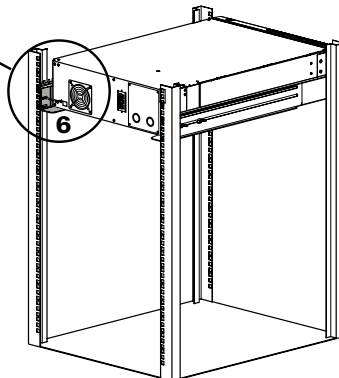
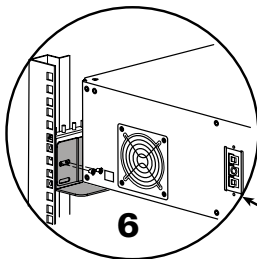

STEP 4 EX RT CLA Charger Module Connections

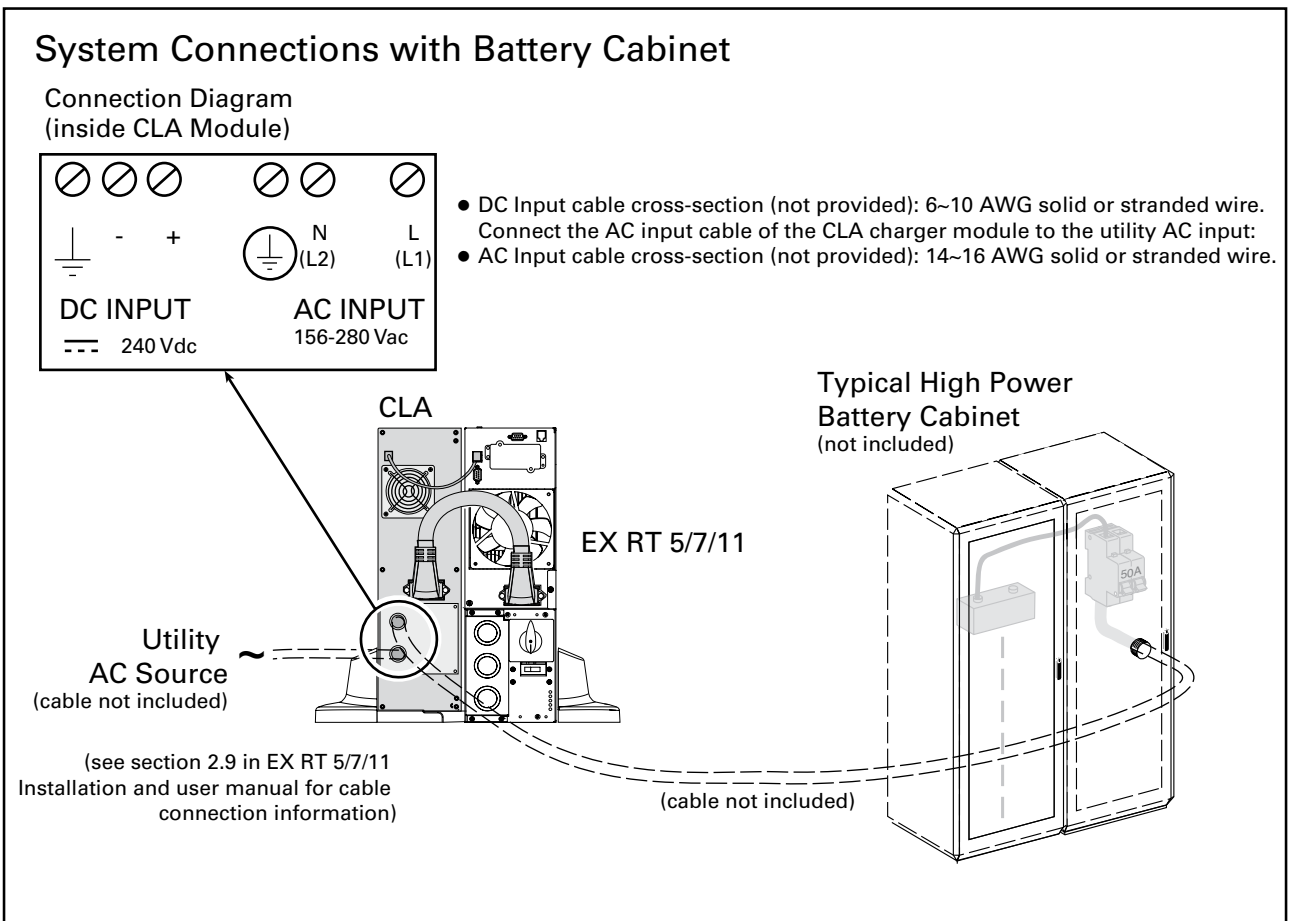

See EX RT 5/7/11 System Installation and User Manual for initial start-up procedures.

